

BALDOR® • *RELIANCE*

Product Information Packet

EHM3558T-5

2HP,1755RPM,3PH,60HZ,145T,3530M,TEFC,F1

Copyright © All product information within this document is subject to Baldor Electric Company copyright © protection, unless otherwise noted.

Part Detail							
Revision:	G	Status:	PRD/A	Change #:		Proprietary:	No
Type:	AC	Prod. Type:	3530M	Elec. Spec:	35WGM840	CD Diagram:	
Enclosure:	TEFC	Mfg Plant:		Mech. Spec:	35Z141	Layout:	
Frame:	145T	Mounting:	F1	Poles:	04	Created Date:	10-07-2010
Base:	RG	Rotation:	R	Insulation:	F	Eff. Date:	08-28-2012
Leads:	3#18	Literature:		Elec. Diagram:		Replaced By:	

Nameplate NP2094E06B03

CAT.NO.	EHM3558T-5						
SPEC.	35Z141M840G1						
HP	2						
VOLTS	575						
AMPS	2.4						
RPM	1755						
FRAME	145T	HZ	60	PH	3		
SER.F.	1.15	CODE	L	DES	B	CL	F
NEMA-NOM-EFF	86.5	PF	73				
RATING	40C AMB-CONT						
CC	010A	USABLE AT 208V					
DE	6205	ODE	6203				
AUTO	N	MANUAL	N	NONE	Y		
ENCL	TEFC	SN					
BLANK							

Parts List		
Part Number	Description	Quantity
SA204758	SA 35Z141M840G1	1.000 EA
RA192004	RA 35Z141M840G1	1.000 EA
34FN3002B01	EXTERNAL FAN, PLASTIC, .637/.639 HUB W/	1.000 EA
S/P107-000-001	SUPER E PROC'S-FS & WS PLTS-POLYREX EM G	1.000 EA
NS2512A01	INSULATOR, CONDUIT BOX X	1.000 EA
35CB3009	35 CB CASTING W/1.09 DIA. LEAD HOLE @ 6:	1.000 EA
36GS1000SP	GASKET-CONDUIT BOX, .06 THICK #SV-330 LE	1.000 EA
51XB1016A07	10-16 X 7/16 HXWSSLD SERTYB	2.000 EA
11XW1032G06	10-32 X .38, TAPTITE II, HEX WSHR SLTD U	1.000 EA
35EP3100M01	FREP TEFC 203 BRG W/GRSR (RAISED FH PADS	1.000 EA
HW4500A19	1/4-28X1/4 SLOTTED PLUG F/S	1.000 EA
HW5100A03SP	WAVY WASHER (W1543-017)	1.000 EA
35EP3101B90	STD PU EP-ENCLOSED-205 BRG-W/GREASER	1.000 EA
91XN0540J08	SCREW, 5-40 X 1/2", FHC, AS	2.000 EA
HW4500A19	1/4-28X1/4 SLOTTED PLUG F/S	1.000 EA
XY1032A02	10-32 HEX NUT DIRECTIONAL SERRATION	4.000 EA
51XB1214A16	12-14X1.00 HXWSSLD SERTYB	1.000 EA
35FH4005A84SP	IEC FH W/GRSR, NO DIMPLES W/AUTOPHERETIC	1.000 EA
51XW1032A06	10-32 X .38, TAPTITE II, HEX WSHR SLTD S	3.000 EA
35CB4521GX	CONDUIT BOX LID KIT	1.000 EA
51XW0832A07	8-32 X .44, TAPTITE II, HEX WSHR SLTD SE	4.000 EA
HW2501D13SP	KEY, 3/16 SQ X 1.375	1.000 EA
HA7000A01	KEY RETAINER 7/8" DIA SHAFT	1.000 EA
MJ1000A75	GREASE, POLYREX EM EXXON	0.050 LB

Parts List (continued)		
Part Number	Description	Quantity
MG1000G27	PAINT- S9282E CHARCOAL GREY	0.017 GA
HA3100A22	THRUBOLT 10-32 X 10.125	4.000 EA
LB1125C02	SUPER-E (STOCK CTN LABEL SUPER-E WITH FL	1.000 EA
LB1357	ENERGY GUIDE LABEL (BOX LABEL)	1.000 SH
LC0006	CONNECTION LABEL	1.000 EA
NP2094E06B03	NP LABEL W/BARCODE (PREM EFF HVAC MTR)	1.000 EA
36PA1000	PACK GROUP W/LB5001	1.000 EA

Performance Data at 575V, 60Hz, 2.0HP (Typical performance - Not guaranteed values)

General Characteristics

Full Load Torque:	5.95 LB-FT	Start Configuration:	DOL
No-Load Current:	1.48 Amps	Break-Down Torque:	24.1 LB-FT
Line-line Res. @ 25°C.:	11.6 Ohms A Ph / 0.0 Ohms B Ph	Pull-Up Torque:	16.0 LB-FT
Temp. Rise @ Rated Load:	62 C	Locked-Rotor Torque:	18.3 LB-FT
Temp. Rise @ S.F. Load:	73 C	Starting Current:	19.6 Amps

Load Characteristics

% of Rated Load	25	50	75	100	125	150	S.F.
Power Factor:	31.0	50.0	64.0	73.0	78.0	82.0	76.0
Efficiency:	75.1	83.8	86.4	86.6	86.0	85.0	86.2
Speed:	1789.0	1778.0	1767.0	1755.0	1741.0	1727.0	1747.0
Line Amperes:	1.56	1.76	2.03	2.37	2.78	3.22	2.62

Performance Graph at 575V, 60Hz, 2.0HP Typical performance - Not guaranteed values

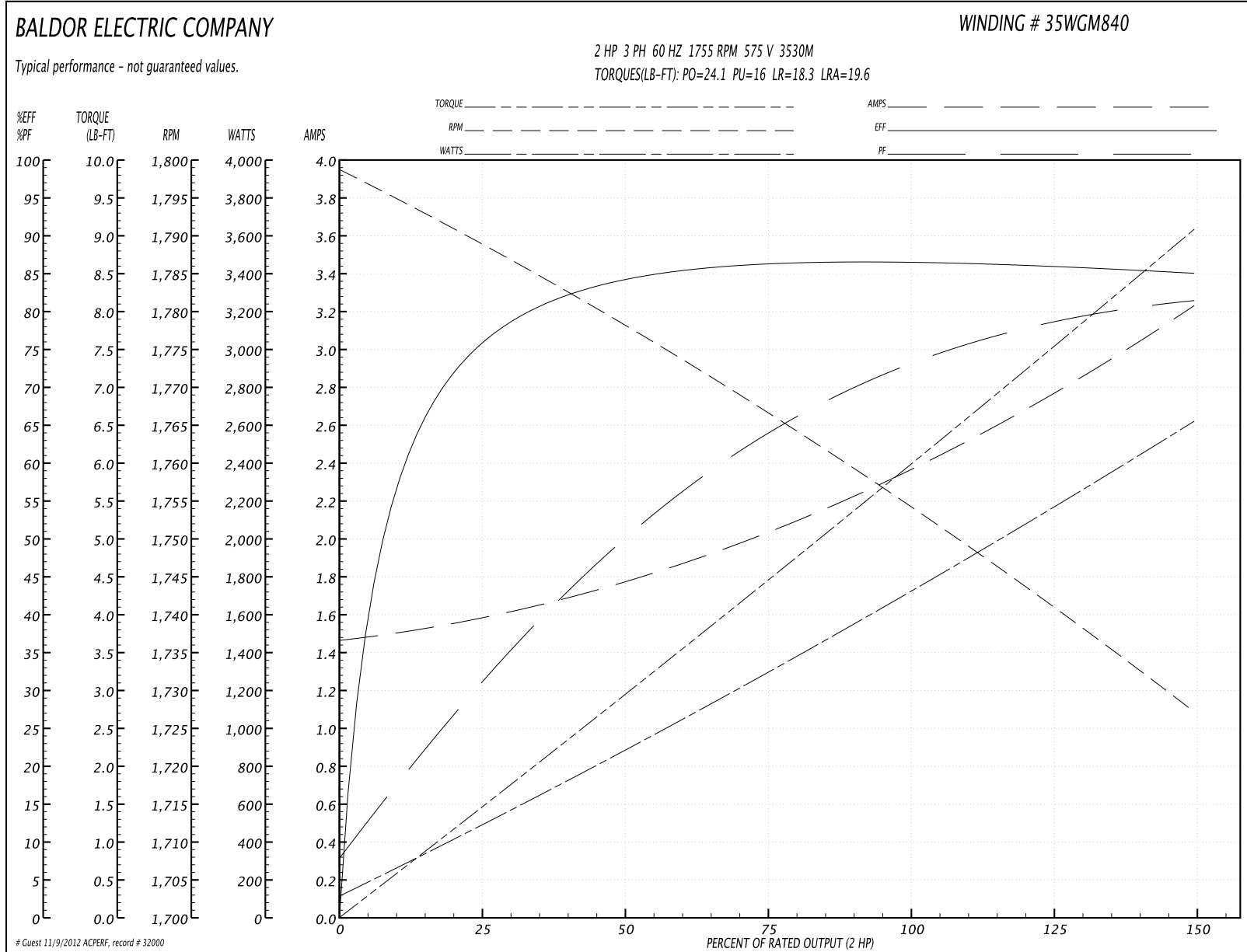

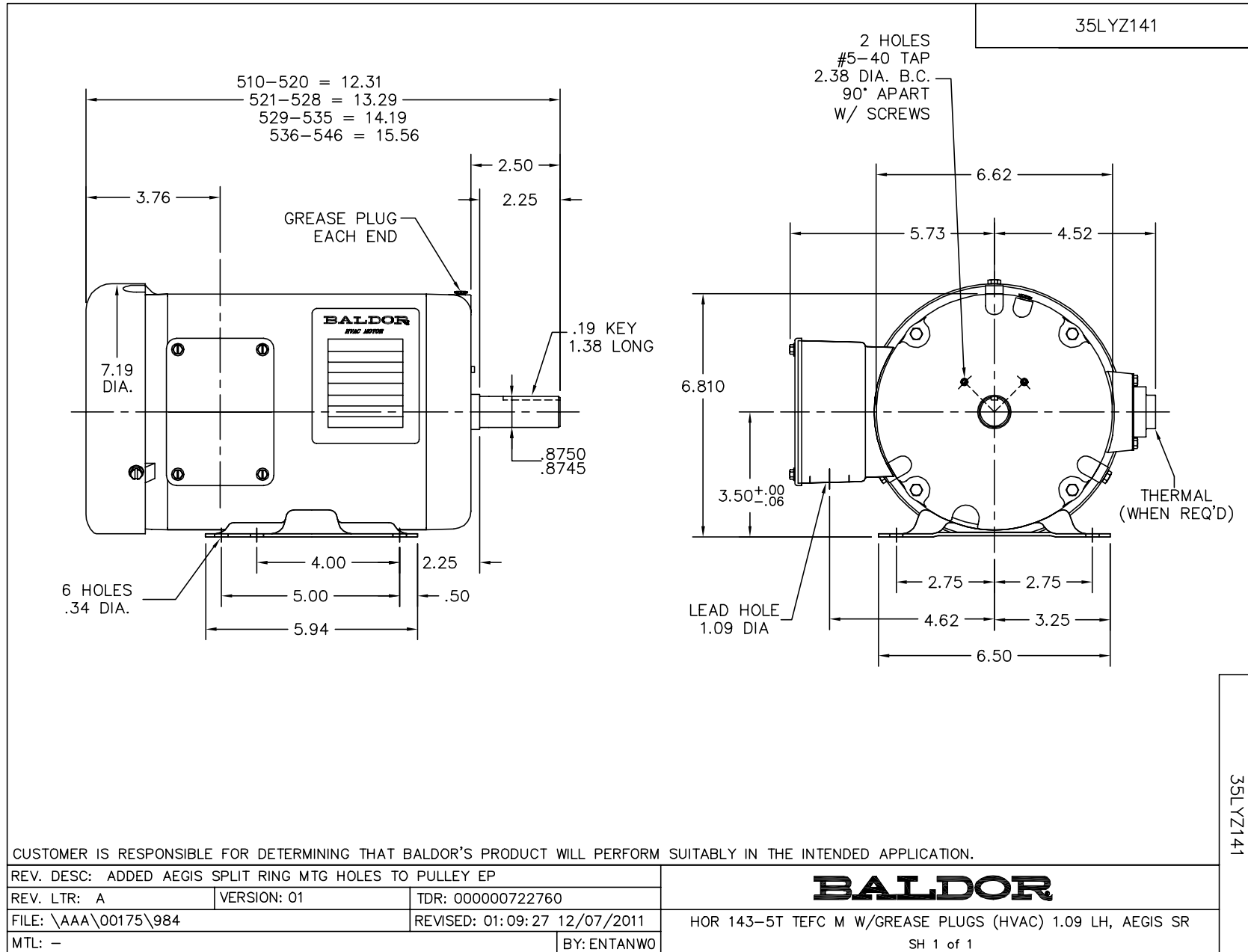

CD0006

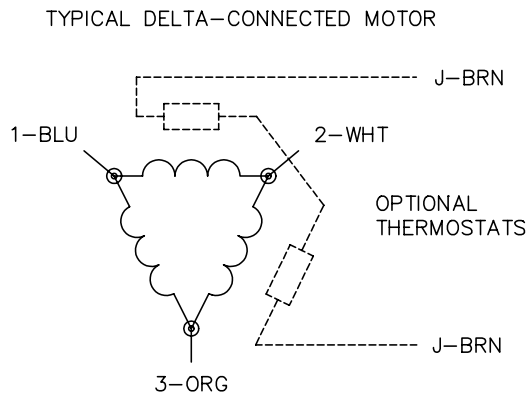
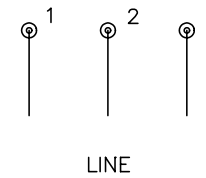
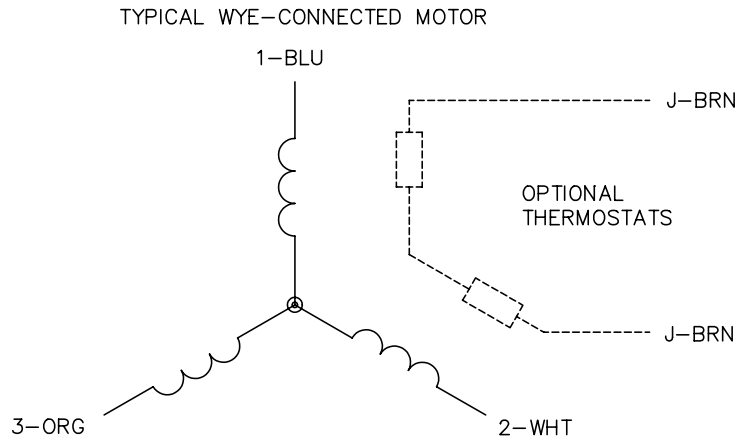

NOTES:

1. THREE LEAD MOTOR MAY BE EITHER WYE CONNECTED OR DELTA CONNECTED.
2. INTERCHANGE ANY TWO LINE LEADS TO REVERSE ROTATION.
3. OPTIONAL THERMOSTATS ARE PROVIDED WHEN SPECIFIED.
4. ACTUAL NUMBER OF INTERNAL PARALLEL CIRCUITS MAY VARY.
5. LEAD COLORS ARE OPTIONAL. LEADS MUST BE NUMBERED AS SHOWN.

REV. DESC: REVISE TO SHOW OPTIONAL COLORS			
REV. LTR: D	BY: JLP	REVISED: 01/21/99 4:02	TDR: 0171435
9000D		FILE: AAA00005141	MDL: -
		MTL: -	

BALDOR ELECTRIC Co.

3PH, SV, 3 LEADS, WYE OR DELTA CONNECTED

CD0006