

BALDOR® • ***RELIANCE***

Product Information Packet

CTM2333T

15HP,1760RPM,3PH,60HZ,254,T,0756M,TEAO,F

Copyright © All product information within this document is subject to Baldor Electric Company copyright © protection, unless otherwise noted.

Part Detail							
Revision:	J	Status:	PRD/A	Change #:		Proprietary:	No
Type:	AC	Prod. Type:	0756M	Elec. Spec:	07WGX739	CD Diagram:	
Enclosure:	TEAO	Mfg Plant:		Mech. Spec:	07J566	Layout:	
Frame:	254T	Mounting:	F1	Poles:	04	Created Date:	10-28-2005
Base:	RG	Rotation:	R	Insulation:	F	Eff. Date:	07-29-2010
Leads:	9#14	Literature:		Elec. Diagram:		Replaced By:	

Nameplate NP1258E							
CAT.NO.	CTM2333T						
SPEC.	07J566X739H1						
HP	15						
VOLTS	208-230/460						
AMP	40-37/18.5						
RPM	1760						
FRAME	254T	HZ	60	PH	3		
SER.F.	1.15	CODE	J	DES	A	CL	F
NEMA-NOM-EFF	91	PF	83				
RATING	40C AMB-CONT						
CC	USABLE AT 208V						
DE	6309	ODE	6206				
ENCL	TEAO	SN					
	1700 FPM AT 170CFM						

Parts List		
Part Number	Description	Quantity
SA135303	SA 07J566X739H1	1.000 EA
RA125064	RA 07J566X739H1	1.000 EA
S/P101-000-000	EPACT PROCEDURES-FS PLANT-POLYREX EM, NO	1.000 EA
HW3201A01	1/2-13 EYEBOLT	1.000 EA
HA7205	"L" SHAPE LIFTING LUG FOR 37,39 & 40 FRA	2.000 EA
09CB1002A26G	KOBX W/1.00 NPT LD HL .25-20 TAP FOR LID	1.000 EA
RM1017	LEAD SEPERATOR GASKET MODEL 307 1/8" THK	1.000 EA
51XW2520A12	.25-20 X .75, TAPTITE II, HEX WSHR SLTD	2.000 EA
HA4044A00	PLUG,PIPE 1/8 NPT PLASTIC SQUARE HEAD	2.000 EA
11XW1032G06	10-32 X .38, TAPTITE II, HEX WSHR SLTD U	1.000 EA
HW3001B01	003SS CUP WASHER, FOR #8 SCREW	1.000 EA
10XN2520S06	1/4 20X3/8 HX HD CAP S.S.	2.000 EA
WD1000B16	KPA-4C BURNDY TERMINAL	2.000 EA
37EP1100C42G	35 EP FR TENV 206 BRG NO GR SR .125 NPT(E	1.000 EA
HA4001A01SP	DRAIN PLUG, PLASTIC (MICRO PLAS)	1.000 EA
HA4044A00	PLUG,PIPE 1/8 NPT PLASTIC SQUARE HEAD	2.000 EA
HW5100A06	W2420-025 WVY WSHR (WB)	1.000 EA
07EP1116A36G	PUEP, 309 LOCK BRG, (3).125 NPT(GRAY)	1.000 EA
HA4001A01SP	DRAIN PLUG, PLASTIC (MICRO PLAS)	1.000 EA
HA4044A00	PLUG,PIPE 1/8 NPT PLASTIC SQUARE HEAD	2.000 EA
10XN2520A32	1/4 X 2 HEX HEAD CAP SCR, GRADE 2	4.000 EA
XY3118A12	5/16-18 HEX NUT DIRECTIONAL SERRATION	4.000 EA
12CB1503A01G	CONDUIT BOX LID, MACH, WITH LIP, GREY	1.000 EA
12GS1002	GASKET, CONDUIT BOX LID, NEOP	1.000 EA

Parts List (continued)		
Part Number	Description	Quantity
10XN2520A24	1/4-20X 1 1/2 HEX HD X	2.000 EA
HW1001A25	LOCKWASHER 1/4, ZINC PLT .493 OD, .255 I	2.000 EA
HW2501G25	KEY, 3/8 SQ X 2.875	1.000 EA
HA7000A03	KEY RETAINER RING 1.62 & 1.88 DIA. SH	1.000 EA
HW4600B67	FORSHEDA #V45A FACE SEAL	1.000 EA
MJ5001A01	46-665 RED SEALER	0.001 QT
85XU0407S04	4X1/4 U DRIVE PIN STAINLESS	2.000 EA
LB1115	LABEL,LIFTING DEVICE	1.000 EA
LB1002	LABEL,MARINE DUTY (ON ROLLS)	1.000 EA
LB1182	WARNING LABEL FOR MOTORS WITH EYENUTS	1.000 EA
MJ1000A75	GREASE, POLYREX EM EXXON	0.050 LB
MG1025Z20	ACTIVATOR WILKOFAS 060.32	0.010 GA
MG1025G29	PAINT 789.205 DARK GRAY METALLIC (USE W/	0.036 GA
HA3104A25	THRUBOLT .31-18 X 14.75	4.000 EA
LB1125C04	STD-E (STOCK CTN LABEL STD-E WITH FLAG)	1.000 EA
LC0005E01	CONN.DIA./WARNING LABEL (LC0005/LB1119)	1.000 EA
NP1258E	SS CP UL CSA CC	1.000 EA
07PA1011	PKG GRP, 07 CAST IRON PK1181	1.000 EA
10XL3808A28	3/8 X 1 3/4" LAG SCREW	2.000 EA

Performance Data at 460V, 60Hz, 15.0HP (Typical performance - Not guaranteed values)

General Characteristics							
Full Load Torque:	44.6 LB-FT			Start Configuration:	DOL		
No-Load Current:	7.39 Amps			Break-Down Torque:	167.1 LB-FT		
Line-line Res. @ 25°C.:	0.618 Ohms A Ph / 0.0 Ohms B Ph			Pull-Up Torque:	71.5 LB-FT		
Temp. Rise @ Rated Load:	65 C			Locked-Rotor Torque:	101.3 LB-FT		
Temp. Rise @ S.F. Load:	83 C			Starting Current:	147.3 Amps		
Load Characteristics							
% of Rated Load	25	50	75	100	125	150	S.F.
Power Factor:	47.0	68.0	78.0	83.0	84.0	85.0	84.0
Efficiency:	87.6	91.6	92.1	91.6	90.6	89.3	91.0
Speed:	1791.0	1783.0	1775.0	1765.0	1755.0	1743.0	1759.0
Line Amperes:	8.47	11.1	14.5	18.6	22.9	27.7	21.2

Performance Graph at 460V, 60Hz, 15.0HP Typical performance - Not guaranteed values

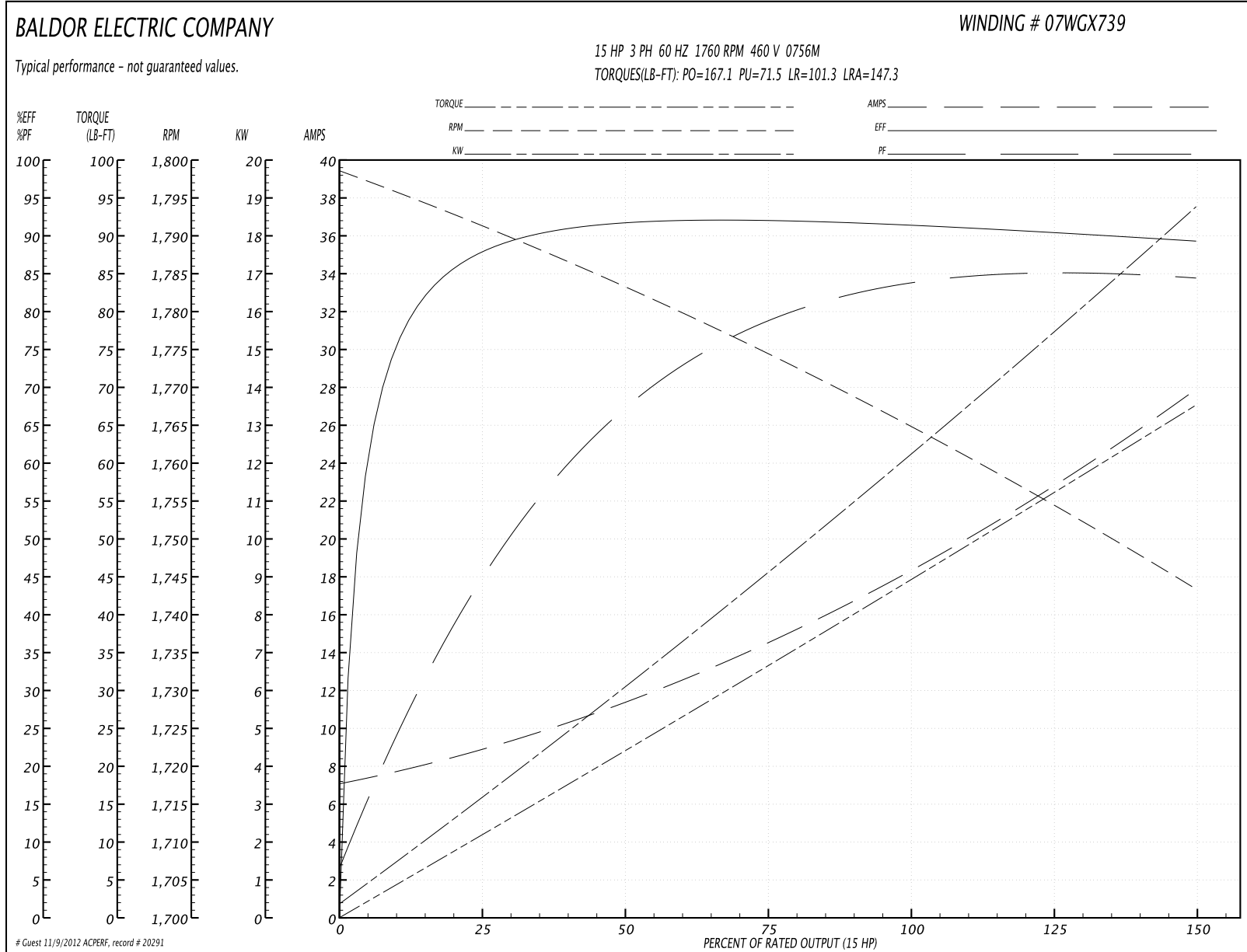

07LYJ566

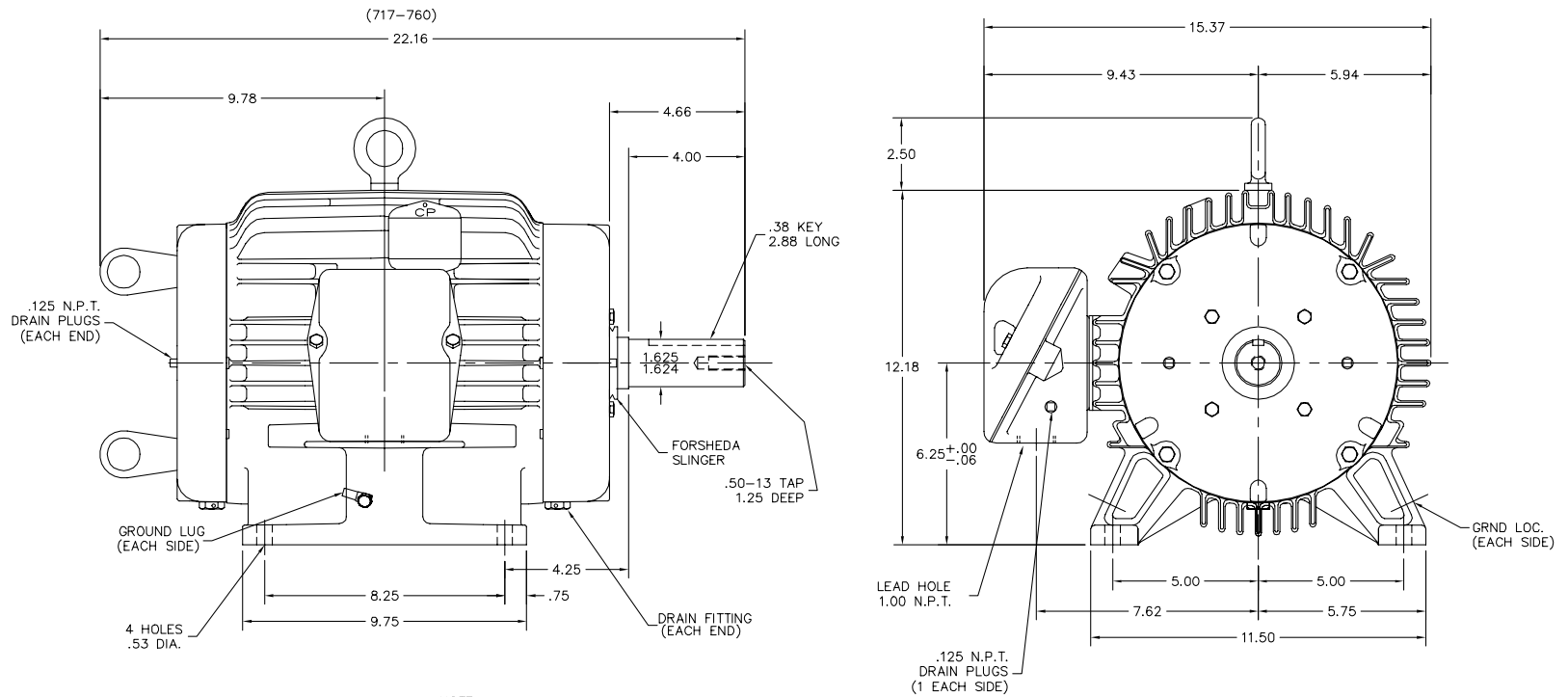

NOTE:
FOR VERTICAL SHAFT UP LIFTING,
REMOVE EYE BOLT FROM TOP OF MOTOR
AND SCREW INTO END OF SHAFT

CUSTOMER IS RESPONSIBLE FOR DETERMINING THAT MOTOR PERFORMANCE IS SUITABLE IN THE APPLICATION.

REV. DESC: REMOVE INPRO & ADD SLINGER; CHG TO SEALED BRGS		
REV. LTR: A	VERSION: 01	TDR: 000000387541
FILE: \AAA\00091\104	REVISED: 14:54:23 02/09/2006	BY: ENSTEKO
MTL: -		

BALDOR ELECTRIC Co.

STD HORZ 254T TEAO CP COOLING TOWER, VERT LIFT, SEALED BRGS

07LYJ566

CD0005



LOW VOLTAGE (2Y)

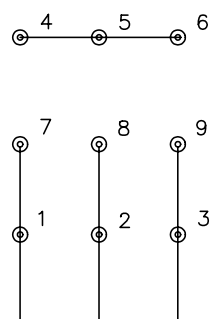

LINE

HIGH VOLTAGE (1Y)

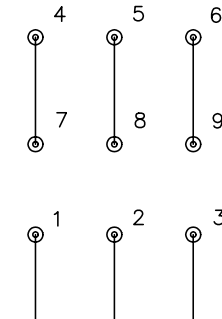

LINE

NOTES:

1. INTERCHANGE ANY TWO LINE LEADS TO REVERSE ROTATION.
2. OPTIONAL THERMOSTATS ARE PROVIDED WHEN SPECIFIED.
3. ACTUAL NUMBER OF INTERNAL PARALLEL CIRCUITS MAY BE A MULTIPLE OF THOSE SHOWN ABOVE.
4. LEAD COLORS ARE OPTIONAL. LEADS MUST ALWAYS BE NUMBERED AS SHOWN.

REV. DESC: REVISE TO SHOW OPTIONAL COLORS			
REV. LTR: E	BY: JLP	REVISED: 01/19/99 10:15	TDR: 0171435
90000		FILE: AAA00005140	MDL: -
		MTL: -	

BALDOR ELECTRIC Co.

3PH, DV, 9 LEADS

CD0005