

# **BALDOR® • RELIANCE**

## **Product Information Packet**

# **CECP4107T**

**25HP,3510RPM,3PH,60HZ,284TSC,0950M,TEFC**

Copyright © All product information within this document is subject to Baldor Electric Company copyright © protection, unless otherwise noted.

Part Detail									
Revision:	C	Status:	PRD/A	Change #:		Proprietary:	No		
Type:	AC	Prod. Type:	0950M	Elec. Spec:	09WGW440	CD Diagram:			
Enclosure:	TEFC	Mfg Plant:		Mech. Spec:	09H426	Layout:			
Frame:	284TSC	Mounting:	F1	Poles:	02	Created Date:	01-10-2011		
Base:	RG	Rotation:	R	Insulation:	F	Eff. Date:	10-15-2012		
Leads:	9#10	Literature:		Elec. Diagram:		Replaced By:			
Nameplate NP1260E									
CAT.NO.	CECP4107T								
SPEC.	09H426Z440G2								
HP	25								
VOLTS	230/460								
AMP	54/27								
RPM	3510								
FRAME	284TSC	HZ	60	PH	3				
SER.F.	1.15	CODE	G	DES	B	CL	F		
NEMA-NOM-EFF	92.4	PF	91						
RATING	40C AMB-CONT								
CC	010A	USABLE AT 208V	60						
DE	6311	ODE	6309						
ENCL	TEFC	SN							

Parts List		
Part Number	Description	Quantity
SA214811	SA 09H426Z440G2	1.000 EA
RA202013	RA 09H426Z440G2	1.000 EA
37FN3002C02	EXFN, PLASTIC, 6.00 OD, 1.500 ID	1.000 EA
S/P107-000-006	SUPER-E(284 FR. & UP)-ZK PLANT,POLYREX E	1.000 EA
09CB1002A31P	KOBX W/1.25 NPT LEAD HOLE & 2.62 MTG HOL	1.000 EA
09GS1010	GASKET, DWG, LEADWIRE SEPERATOR	1.000 EA
10XN2520K12	1/4-20 X.75 GRD 5	2.000 EA
HW1001A25	LOCKWASHER 1/4, ZINC PLT .493 OD, .255 I	2.000 EA
WD1000B16	KPA-4C BURNDY TERMINAL	1.000 EA
10XN2520K08	1/4-20 X .50 GRADE #5, STL, ZINC PLATE	1.000 EA
HW1001A25	LOCKWASHER 1/4, ZINC PLT .493 OD, .255 I	1.000 EA
HA3400A39	STUD- 3/8-16 X 6.19 OAL HEX WELKER	4.000 EA
HW1001A38	LOCKWASHER 3/8, ZINC PLT .688 OD, .382 I	4.000 EA
HA4017A08	.125X3.50 GREASER EXTEN. NLA	1.000 EA
HA4017A10	1/8X1.25 GREASE EXT (F/S)	1.000 EA
HW4019A01	PIPE COUPLING 1/8 NPT,STEEL,ZINC COATING	1.000 EA
HW5100A11	W3917-042 WVY WSHR (WB)	1.000 EA
10XN2520K28	1/4-20 X 1.75" HX HD SCRWGRADE 5, ZINC P	2.000 EA
09EP1310A08P	SPL FACE MTD EP 284-6TC 309 ENCL 311 BRG	1.000 EA
10XN3816K28	3/8-16 X 1.75 HEX HD CAP SCREW, GRADE 5	4.000 EA
HW1001A38	LOCKWASHER 3/8, ZINC PLT .688 OD, .382 I	4.000 EA
10XN3118K40	5/16-18 X 2.50" HEX HD, GRADE 5	4.000 EA
09FH1000P	FAN COVER, CAST W/EPOXY PRIMER	1.000 EA
HW1001A38	LOCKWASHER 3/8, ZINC PLT .688 OD, .382 I	4.000 EA

Parts List (continued)		
Part Number	Description	Quantity
XY3816A12	3/8-16 FINISHED NUT	4.000 EA
HW4600B40	V-RING SLINGER 2.000 X 2.680 X 0.280	1.000 EA
HA1005A18	SLINGER, OD 3.00, ID 1.610	1.000 EA
12CB1503A01P	KOLD MACH, W/LIP & EPOXY PRIMER	1.000 EA
12GS1002	GASKET, CONDUIT BOX LID, NEOP	1.000 EA
10XN3118K16	5/16-18 X 1" GRADE #5, STL, ZINC PLATE	2.000 EA
HW1001A31	LOCKWASHER 5/16, ZINC PLT.591 OD, .319 I	2.000 EA
HW2501G17	KEY, 3/8 SQ X 1.875	1.000 EA
MJ5001A01	46-665 RED SEALER	0.031 QT
MJ5001A14	DYNAPRO SEAL, CP MOTORS VC#2508050 (603	0.023 EA
LB1115	LABEL,LIFTING DEVICE	1.000 EA
LB1002	LABEL,MARINE DUTY (ON ROLLS)	1.000 EA
LB5040	INSTRUCTION TAG, AC & DC	1.000 EA
09EP1118A05GP6	FREP MACH, 309 BRG. EPOXY PRIMER	1.000 EA
HW4500A17	317400 ALEMITE GREASE RELIEF	1.000 EA
HW4500A21	1618BALEMITE FITTING 825 UNIVERSAL	1.000 EA
HA4001A01SP	DRAIN PLUG, PLASTIC (MICRO PLAS)	1.000 EA
HA4051A00	PLASTIC CAP FOR GREASE FITTING	1.000 EA
MJ1000A75	GREASE, POLYREX EM EXXON	0.080 LB
HW4500A03	GREASE FITTING, .125 NPT 1610(ALEMITE) 8	1.000 EA
HW4500A17	317400 ALEMITE GREASE RELIEF	1.000 EA
HA4001A01SP	DRAIN PLUG, PLASTIC (MICRO PLAS)	1.000 EA
HA4051A00	PLASTIC CAP FOR GREASE FITTING	1.000 EA
HW2500A25	WOODRUFF KEY USA #1008 #BLOW CARBON STEE	1.000 EA

Parts List (continued)		
Part Number	Description	Quantity
51XB1214A20	12-14X1.25 HXWSSLD SERTYB	1.000 EA
MG1025N19	PAINT, 778.50 WILKO, RELIANCE ELEC GREEN	0.050 GA
85XU0407S04	4X1/4 U DRIVE PIN STAINLESS	2.000 EA
LB1119	WARNING LABEL	1.000 EA
LB1125C02	SUPER-E (STOCK CTN LABEL SUPER-E WITH FL	4.000 EA
LB1357	ENERGY GUIDE LABEL (BOX LABEL)	1.000 SH
LC0181	CONNECTION LABEL	1.000 EA
NP1260E	SS CP SUPER-E UL CSA CC	1.000 EA
40PA1005	PACKAGING GROUP, 09 STD	1.000 EA

**Performance Data at 460V, 60Hz, 25.0HP (Typical performance - Not guaranteed values)**

General Characteristics							
Full Load Torque:	37.3 LB-FT			Start Configuration:	DOL		
No-Load Current:	5.42 Amps			Break-Down Torque:	103.0 LB-FT		
Line-line Res. @ 25°C.:	0.387 Ohms A Ph / 0.0 Ohms B Ph			Pull-Up Torque:	49.7 LB-FT		
Temp. Rise @ Rated Load:	73 C			Locked-Rotor Torque:	57.9 LB-FT		
Temp. Rise @ S.F. Load:	91 C			Starting Current:	176.0 Amps		
Load Characteristics							
% of Rated Load	25	50	75	100	125	150	S.F.
Power Factor:	76.0	90.0	93.0	93.0	92.0	90.0	92.0
Efficiency:	91.1	93.4	93.4	92.4	91.4	90.0	91.8
Speed:	3579.0	3557.0	3535.0	3512.0	3485.0	3456.0	3496.0
Line Amperes:	8.64	14.1	20.4	27.1	34.5	42.6	31.5

Performance Graph at 460V, 60Hz, 25.0HP Typical performance - Not guaranteed values

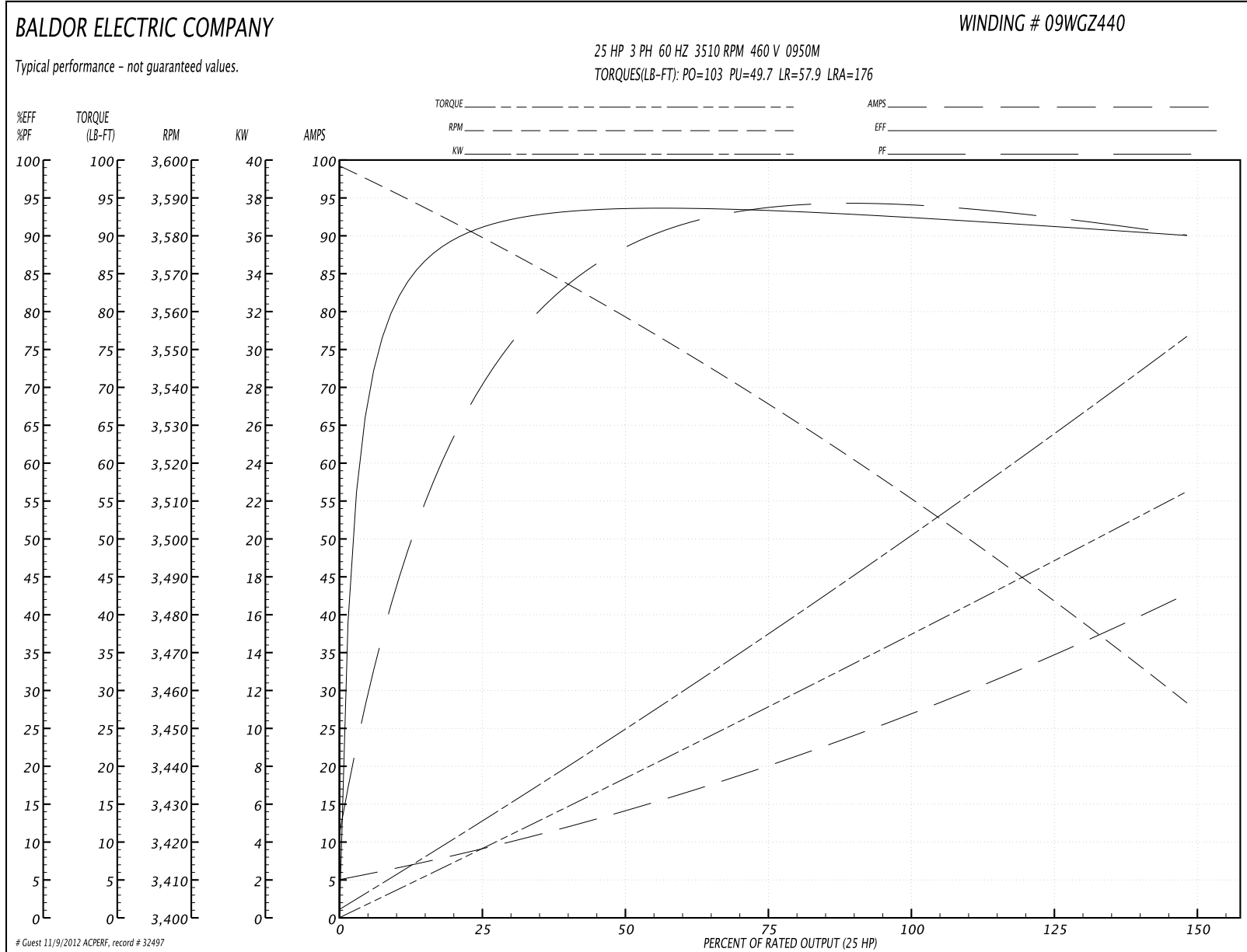

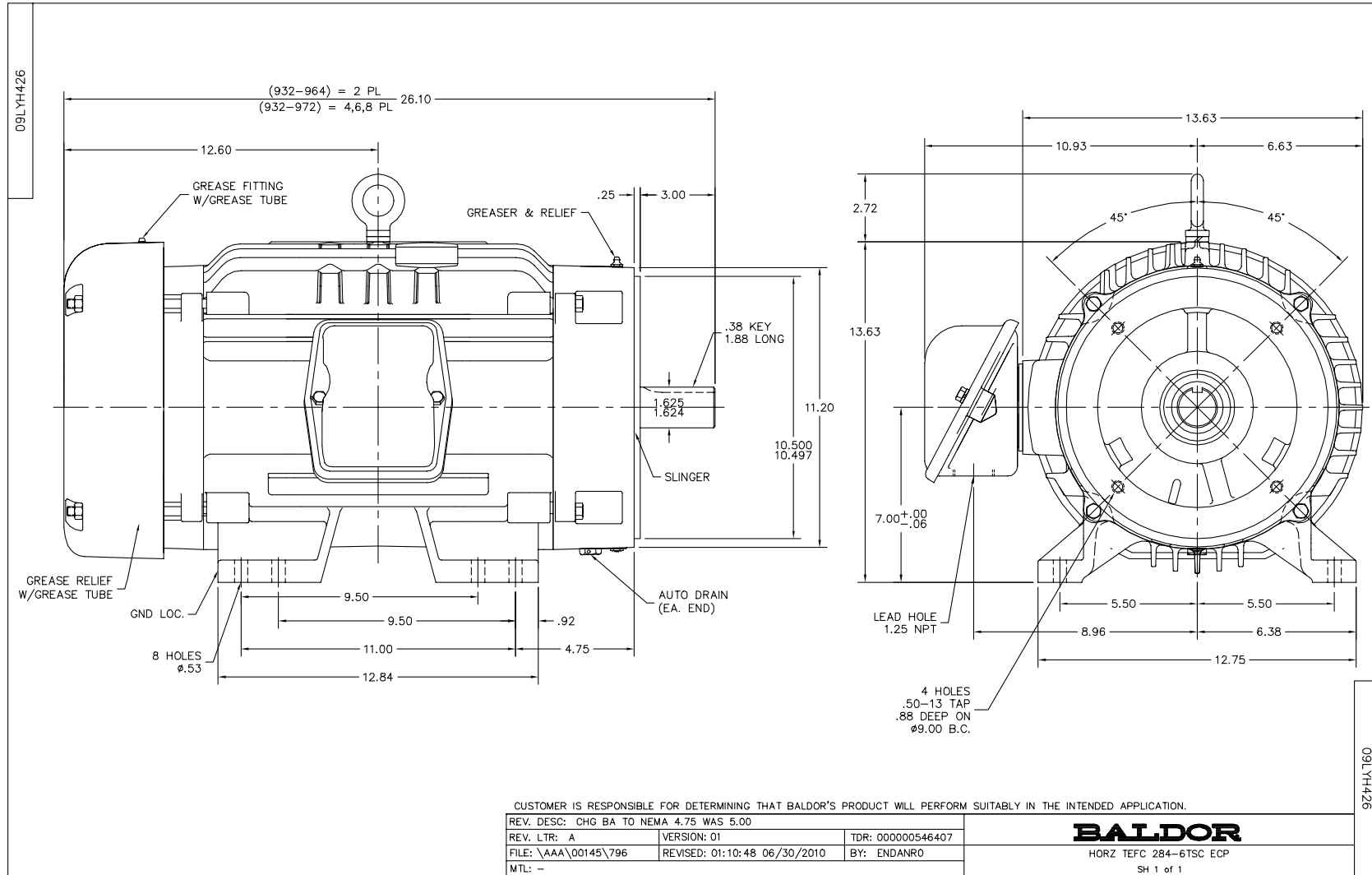



CD0180



LOW VOLTAGE  
(2D)

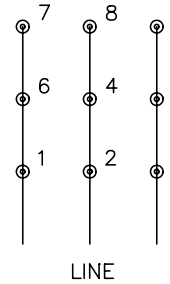

HIGH VOLTAGE  
(1D)

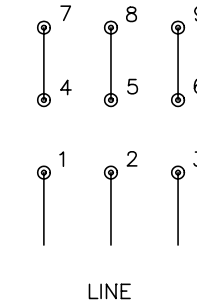

NOTES:

1. INTERCHANGE ANY TWO LINE LEADS TO REVERSE ROTATION.
2. OPTIONAL THERMOSTATS ARE PROVIDED WHEN SPECIFIED.
3. ACTUAL NUMBER OF INTERNAL PARALLEL CIRCUITS MAY BE A MULTIPLE OF THOSE SHOWN ABOVE.
4. LEAD COLORS ARE OPTIONAL. LEADS MUST ALWAYS BE NUMBERED AS SHOWN.

REV. DESC: REVISE TO SHOW OPTIONAL COLORS			
REV. LTR: C	BY: JLP	REVISED: 01/21/99 2:28	TDR: 0171435
0810D3		FILE: AAA00005148	MDL: -
		MTL: -	

**BALDOR ELECTRIC Co.**

3PH, DV, 9 LEADS, DELTA CONNECTION

CD0180