

**NEMA AN16DN0AB
NEMA Size 1 Starter**

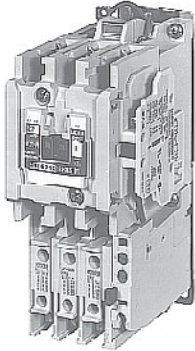

NEMA Size 1 Contactor

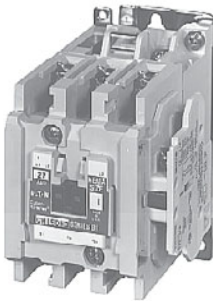

33.1 Freedom Series

Product Overview	2
Features, Benefits and Functions	2
Standards and Certifications	3
Catalog Number Selection	3
Contactors—Non-Reversing and Reversing	4
Starters—Three-Phase Non-Reversing and Reversing, Full Voltage	10
Starters—Single-Phase Non-Reversing, Full Voltage, Bi-Metallic Overload	15
Accessories	21
Renewal Parts	30
Technical Data and Specifications	35
Relays—Thermal Overload	39
C440/ <i>XT</i> Electronic Overload Relay	49

33.2 A200 Series

Contactors—Non-Reversing and Reversing	64
Starters—Non-Reversing and Reversing	70
Relays—Thermal and Fast Trip	91
Thermal Type B, Class 20, Manual Reset	93
Thermal Type A, Class 20, Auto/Manual Reset	96
Type FT Fast Trip, Class 10	99
Heater Selection	102
Relays—Current Sensing Protective	104

33.3 Solenoids—Alternating Current

Product Description	107
Features	107
Product Selection	108
Dimensions	109

33.4 Shoe Brakes—AC and DC Magnetic

Product Description	110
Application Description	110
Features	110
Product Selection	111
Dimensions	113

33.5 Reference Data

IEC Utilization Categories	115
Annex A (informative)	116
Motor Ratings Data	118



Freedom Series

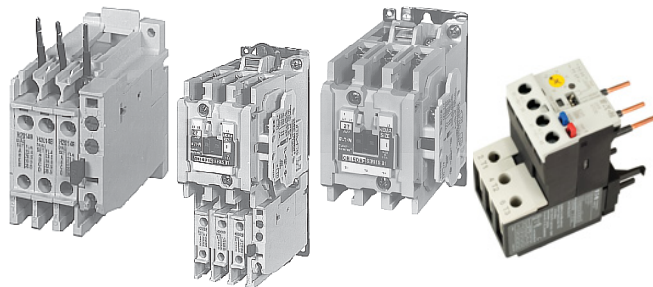

33

Contents

<i>Description</i>	<i>Page</i>
Technical Data and Specifications	
Standards and Certifications	3
Catalog Number Selection	3
Contactors—Non-Reversing and Reversing	4
Starters—Three-Phase Non-Reversing and Reversing, Full Voltage	10
Starters—Single-Phase Non-Reversing, Full Voltage, Bi-Metallic Overload	15
Accessories	21
Renewal Parts	30
Technical Data and Specifications	35
Relays—Thermal Overload	39
C440/ <i>XT</i> Electronic Overload Relay	49

Product Overview

Freedom Series starters and contactors feature a compact, space-saving design, using state-of-the-art technology and the latest in high strength, impact and temperature resistant insulating materials.

Features, Benefits and Functions

Freedom NEMA

- Adjustable bimetallic ambient compensated overload relays with interchangeable heater packs—available in three basic sizes, covering applications up to 900 hp—reducing the number of different contactor/overload relay combinations that have to be stocked. Fixed heater overloads are optional
- Electronic overload relay (C440) available as a stand-alone unit and assembled with Freedom Contactor
- A full line of snap-on accessories— top and side mounted auxiliary contacts, solid-state and pneumatic timers, etc.
- Straight-through wiring— line lugs at top, load lugs at bottom
- Horizontal or vertical mounting on upright panel for application freedom
- Screw type power terminals have captive, backed-out self-lifting pressure plates with \pm screws—reduced wiring time
- Accessible terminals for easy wiring. Optional fingerproof shields available to prevent electrical shock
- Top located coil terminals convenient and readily accessible. 45 mm contactor magnet coils have three terminals, permitting either top or diagonal wiring—easy to replace European or U.S. style starters or contactors without changing wiring layout
- Designed to meet or exceed NEMA, UL, CSA, VDE, BS and other international standards and listings
- American engineering— built by Eaton, using the latest in statistical process control methods to produce high quality, reliable products
- Sized based on standard NEMA classifications
- Easy coil change and inspectable/replaceable contacts
- Available in open and NEMA Type 1, 3R, 4/4X and 12 enclosures

Standards and Certifications

- Standard: designed to meet or exceed UL, NEMA, IEC, CSA, VDE and BS
- UL listed: UL File #E1491, Guide #NLDX—Open and NEMA 1, 4, 12 Enclosed
- CSA Certified: CSA File #LR353, Class #321104 Open and NEMA 1 Enclosed



ISO 9000 Certification

When you turn to Eaton's products, you turn to quality. The International Standards Organization (ISO) has established a series of standards acknowledged by 91 industrialized nations to bring harmony to the international quest for quality. The ISO certification process covers 20 quality system elements in design, production and installation that must conform to achieve registration. This commitment to quality will result in increased product reliability and total customer satisfaction.

Short Circuit Protection

Fuses and Inverse-Time Circuit Breakers may be selected per Article 430, Part D of the National Electrical Code to protect motor branch circuits from fault conditions. If higher ratings or settings are required to start the motor, do **not** exceed the maximum as listed in Exception No. 2, Article 430-52.

Catalog Number Selection

Freedom Series

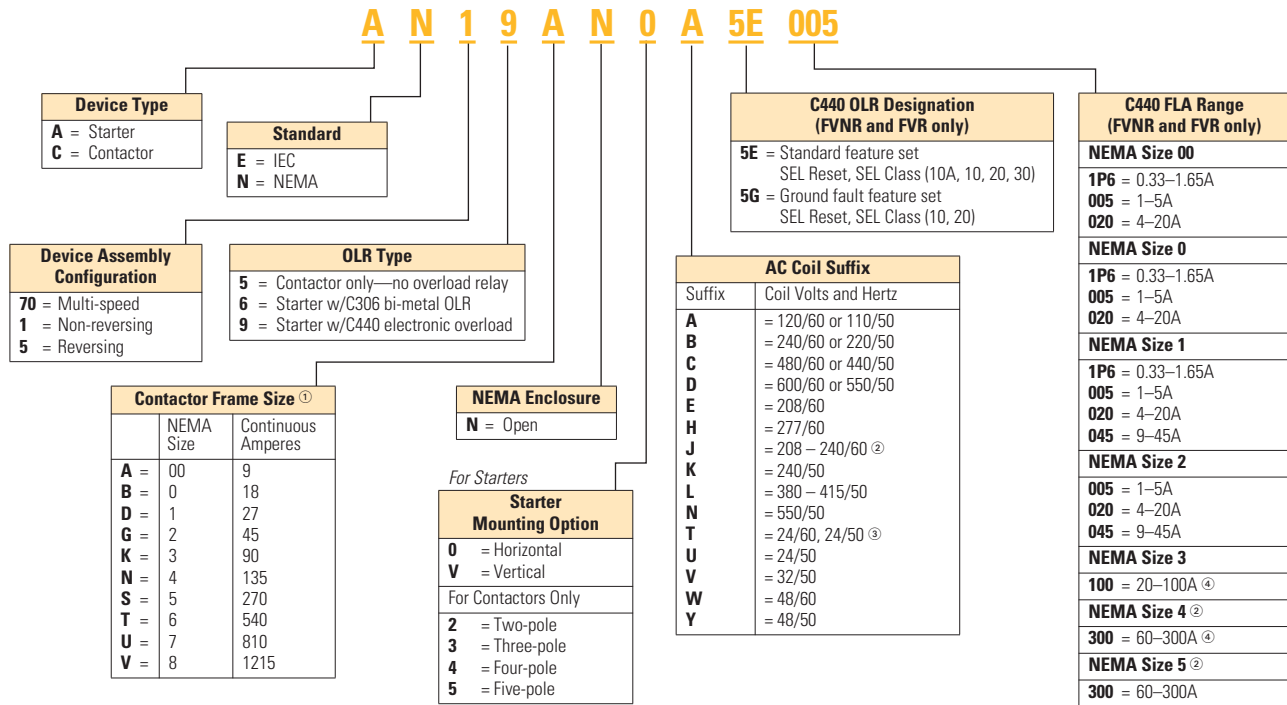

Notes

- ① For contactor only orders, add **B** to end of catalog number if NEMA Size 00–2, 6.
- ② NEMA Sizes 00 and 0 only.
- ③ NEMA Sizes 00 and 0 only. Sizes 1–8 are 24/60 only.
- ④ NEMA Sizes 4 and 5 require the use of CTs with 1-5A OL relay. Size 4 starters are not shipped as assembled units. Order CN15NN01 contactor and 1-5A OL (C440A1A005SAX or C440A2A005SAX) with 60–300A CTs (ZEB-XCT300).

Non-Reversing and Reversing Contactors

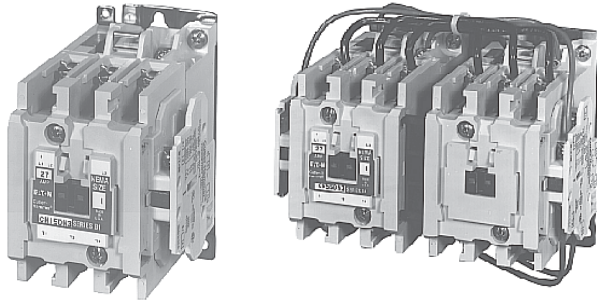

33

Contactors—Non-Reversing and Reversing

Product Description

Non-Reversing

Contactors are most commonly used to switch motor loads in applications where running overcurrent protection is either not required or is provided separately. Contactors consist of a magnetically actuated switch which can be remotely operated by a pushbutton station or pilot device such as a proximity switch, limit switch, float switch, auxiliary contacts, etc.

Reversing

Reversing contactors are used primarily for reversing single- or three-phase motors in applications where running overcurrent protection is either not required or is provided separately. They consist of two contactors mechanically and electrically interlocked to prevent line shorts and energization of both contactors simultaneously.

Contents

<i>Description</i>	<i>Page</i>
Contactors—Non-Reversing and Reversing	
Product Selection	5
Kits and Accessories	6
Renewal Parts Publication Numbers	6
Technical Data and Specifications	7
Dimensions	8
Starters—Three-Phase Non-Reversing and Reversing, Full Voltage	10
Starters—Single-Phase Non-Reversing, Full Voltage, Bi-Metallic Overload	15
Accessories	21
Renewal Parts	30
Technical Data and Specifications	35
Relays—Thermal Overload	39

Features, Benefits and Functions

- Designed specifically for use in applications requiring NEMA ratings. Contactors meet or exceed NEMA standards ICS 2-1993
- Long life twin break, silver cadmium oxide contacts—provide excellent conductivity and superior resistance to welding and arc erosion
- Designed to 3,000,000 electrical operations at maximum hp ratings up through 25 hp at 600V
- Steel mounting plate standard on all open type contactors

Non-Reversing

- Holding circuit contact(s) supplied as standard:
 - Sizes 00–3 have NO auxiliary contact block mounted on right hand side (on Size 00, contact occupies 4th power pole position—no increase in width)
 - Sizes 4–5 have a NO contact block mounted on left side
 - Sizes 6–7 have a 2NO/2NC contact block on top left
 - Size 8 has a NO/NC contact block on top left back and a NO contact block on top right back

Reversing

- One NO-NC side mounted interlock supplied as standard on each contactor for Sizes 00–8

Product Selection

Three-Pole Contactors

NEMA Size 00
CN55AN3AB



NEMA Size 0
CN15BN3AB



NEMA Size 3
CN15KN3A



Type CN15/CN55 NEMA Contactors—Non-Reversing and Reversing

NEMA Size	Continuous Ampere Rating	Maximum UL Horsepower ^①						Non-Reversing Catalog Number	Reversing Catalog Number
		Single-Phase		Three-Phase		480V	600V		
		115V	230V	208V	240V				
00	9	1/3	1	1-1/2	1-1/2	2	2	CN15AN3_B	CN55AN3_B
0	18	1	2	3	3	5	5	CN15BN3_B	CN55BN3_B
1	27	2	3	7-1/2	7-1/2	10	10	CN15DN3_B	CN55DN3_B
2	45	3	7-1/2	10	15	25	25	CN15GN3_B	CN55GN3_B
3	90			25	30	50	50	CN15KN3_	CN55KN3_
4	135			40	50	100	100	CN15NN3_	CN55NN3_
5	270			75	100	200	200	CN15SN3_	CN55SN3_
6	540			150	200	400	400	CN15TN3_B	CN55TN3_B
7	810			200	300	600	600	CN15UN3_	CN55UN3_
8 ^②	1215			400	450	900	900	CN15VN3_	CN55VN3_

Magnet Coils—AC and DC

Contactors listed in this section also have a 50 Hz rating as shown in the adjacent table. Select required contactor by catalog number and replace the magnet coil alpha

designation in the catalog number () with the proper code suffix from the table.

For Sizes 00–2, the magnet coil alpha designation will be the next to the last digit of the listed catalog number.

EXAMPLE: For a 380V, 50 Hz coil, change CN15AN3_B to CN15AN3LB. For all other sizes, the magnet coil alpha designation will be the last digit of the listed catalog number.

For **DC Magnet Coils**, see Accessories, **Pages 28 and 29**.

AC Suffix

Coil Volts and Hertz	Code Suffix
120/60 or 110/50	A
240/60 or 220/50	B
480/60 or 440/50	C
600/60 or 550/50	D
208/60	E
277/60	H
208–240/60 ^③	J
240/50	K

Coil Volts and Hertz	Code Suffix
380–415/50	L
550/50	N
24/60, 24/50 ^④	T
24/50	U
32/50	V
48/60	W
48/50	Y

Notes

^① Maximum horsepower rating of starters for 380V 50 Hz applications:

NEMA Size	00	0	1	2	3	4	5	6	7	8
Horsepower	1-1/2	5	10	25	50	75	150	300	600	900

^② Common control. For separate 120V control, insert letter **D** in 7th position of listed catalog number. Example: CN15VND3C.

^③ NEMA Sizes 00 and 0 only.

^④ NEMA Sizes 00 and 0 only. Sizes 1–8 are 24/60 only.

33.1

NEMA Contactors and Starters

Freedom Series

Two-, Four- and Five-Pole Contactors

33

NEMA Size 2
Five-Pole Contactor
CN15GN5AB

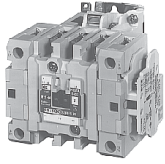

Type CN15 NEMA Contactors—Non-Reversing

NEMA Size	Continuous Ampere Rating	Maximum UL Horsepower Single-Phase (Two-Pole)		Three-Phase				Two-Pole Non-Reversing	Four-Pole Non-Reversing	Five-Pole Non-Reversing
		115V	230V	208V	240V	480V	600V	Catalog Number	Catalog Number	Catalog Number
00	9	1/3	1	1-1/2	1-1/2	2	2	CN15AN2_B	CN15AN4_B	—
0	18	1	2	2	3	5	5	CN15BN2_B	—	—
1	27	2	3	7-1/2	7-1/2	10	10	CN15DN2_B	CN15DN4_B	CN15DN5_B
2	45	3	7-1/2	10	15	25	25	CN15GN2_B	CN15GN4_B	CN15GN5_B
3	90			25	30	50	50	CN15KN2_	—	—
4	135			40	50	100	100	CN15NN2_	—	—
5	270			75	100	200	200	CN15SN2_	—	—
6	540			150	200	400	400	CN15TN2_B	—	—

Magnet Coils—AC and DC

Select required starter by catalog number and replace the magnet coil alpha designation in the catalog number (A) with the proper code suffix from the table.

For Sizes 00–2, the magnet coil alpha designation will be the next to the last digit of the listed catalog number. EXAMPLE: For a 380V, 50 Hz coil, change CN15BN3_B

to CN15BN3LB. For all other sizes, the magnet coil alpha designation will be the last digit of the listed catalog number.

For **DC Magnet Coils**, see Accessories, **Pages 28 and 29**.

AC Suffix

Coil Volts and Hertz	Code Suffix
120/60 or 110/50	A
240/60 or 220/50	B
480/60 or 440/50	C
600/60 or 550/50	D
208/60	E
277/60	H
208–240/60 ①	J
240/50	K

Coil Volts and Hertz	Code Suffix
380–415/50	L
550/50	N
24/60, 24/50 ②	T
24/50	U
32/50	V
48/60	W
48/50	Y

Kits and Accessories

- Auxiliary contacts, contactor mounted—**Pages 25–27**
- Transient suppressor, for magnet coil—**Page 24**
- Timers—solid-state and pneumatic, mount on contactor—**Page 22**

Renewal Parts Publication Numbers

- See **Page 30**

Notes

- ① NEMA Sizes 00 and 0 only.
- ② NEMA Sizes 00 and 0 only. Sizes 1–8 are 24/60 only.

Technical Data and Specifications

Wire (75°C) Sizes—AWG or kcmil—Open and Enclosed

NEMA Size	Power Terminals Line or Load	Control Terminals Cu Only
00	12–16 stranded; 12–14 solid Cu	12–16 stranded
0	8–16 stranded; 10–14 solid Cu	12–14 solid
1	8–14 stranded or solid Cu	
2	3–14 (upper) and/or 6–14 (lower) stranded or solid ^① Cu	
3	1/0–14 Cu/Al	
4	250 mcm–6	
5	750 kcmil–2, or (2) 250 kcmil–3/0 Cu/Al	
6	(2) 750 kcmil–3/0 Cu/Al	
7	(3) 750 kcmil–3/0 Cu/Al	
8	(4) 750 kcmil–4/0 Cu/Al	

Plugging and Jogging Service Horsepower Ratings ^②

NEMA Size	200V	230V	460V	575V
00	—	1/2	1/2	1/2
0	1-1/2	1-1/2	2	2
1	3	3	5	5
2	7-1/2	10	15	15
3	15	20	30	30
4	25	30	60	60
5	60	75	150	150
6	125	150	300	300

Notes

^① Two compartment box lug.

^② Maximum horsepower where operation is interrupted more than 5 times per minute or more than 10 times in a 10 minute period.
NEMA standard ICS 2-1993 table 2-4-3.

33.1

NEMA Contactors and Starters

Freedom Series

Dimensions

Approximate Dimensions in Inches (mm)

Non-Reversing Contactors—Open Type

33

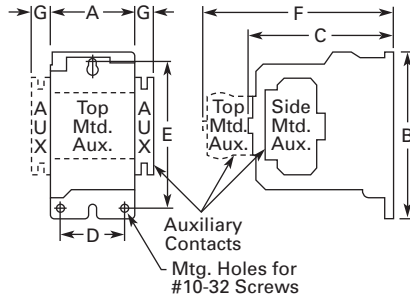

Sizes 00, Two- to Four-Pole

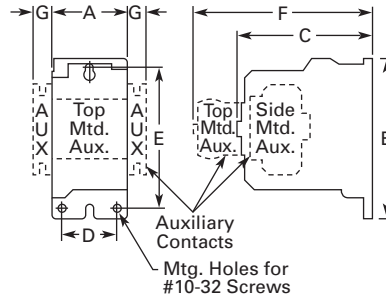

Sizes 0-2, Two- and Three-Pole

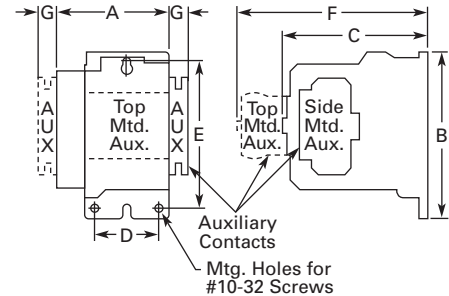

Sizes 0-2, Two- and Three-Pole

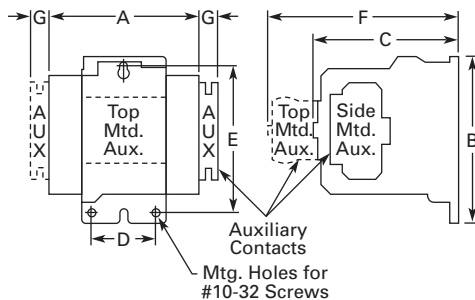

Sizes 1-2, Five-Pole

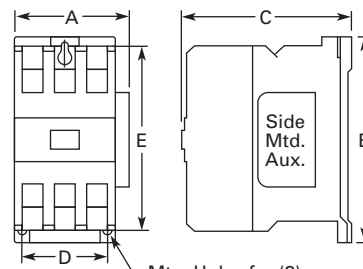

Size 3

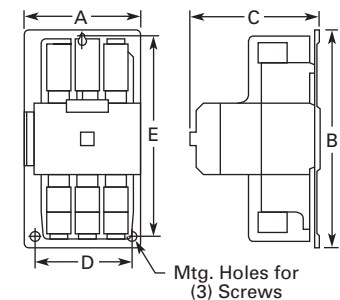

Sizes 4-5

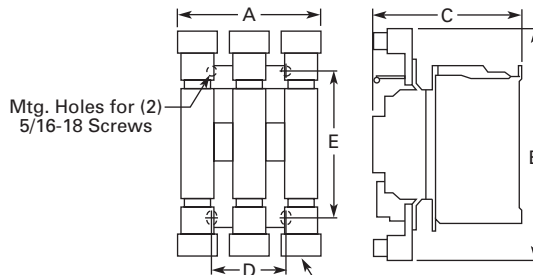

Size 6

Dimensions and Shipping Weights

NEMA Size	Number of Poles	Wide A	High B	Deep C	Mounting D	Mounting E	F	G	Shipping Weight Lbs (kg)
00	2-4	1.75 (44.5)	3.88 (98.6)	3.49 (88.6)	1.50 (38.1) ①	3.38 (85.9)	4.62 (117.3)	0.54 (13.7)	1.7 (0.7)
0	2-3	1.75 (44.5)	3.88 (98.6)	3.49 (88.6)	1.50 (38.1) ①	3.38 (85.9)	4.62 (117.3)	0.54 (13.7)	1.8 (0.8)
1-2	2-3	2.56 (65.0)	5.05 (128.3)	4.44 (112.8)	2.00 (50.8) ①	4.50 (114.3)	5.80 (147.3)	0.54 (13.7)	3.1 (1.4)
1-2	4	3.44 (87.4)	5.05 (128.3)	4.44 (112.8)	2.00 (50.8) ①	4.50 (114.3)	5.80 (147.3)	0.54 (13.7)	3.6 (1.6)
1-2	5	4.32 (109.7)	5.05 (128.3)	4.44 (112.8)	2.00 (50.8) ①	4.50 (114.3)	5.80 (147.3)	0.54 (13.7)	4.0 (1.8)
3	2-3	4.08 (103.6)	7.17 (182.1)	5.94 (150.9)	3.00 (76.2)	6.63 (168.4)	—	—	8.5 (3.9)
4	2-3	7.05 (179.1)	9.11 (231.4)	7.25 (184.2)	6.00 (152.4)	8.50 (215.9)	—	—	20.0 (9.1)
5	2-3	7.05 (179.1)	13.12 (333.2)	7.78 (197.6)	6.00 (152.4)	12.50 (317.5)	—	—	23.0 (10.4)
6	3	8.63 (219.2)	13.54 (343.9)	8.88 (225.6)	4.33 (110.0)	8.63 (219.2)	—	—	35.0 (15.9)
7	3	11.02 (279.9)	19.30 (490.2)	11.46 (291.1)	6.89 (175.0)	11.02 (279.9)	—	—	100.0 (45.4)
8	3	13.00 (330.2)	24.50 (622.3)	13.63 (346.2)	4.22 (107.2)	14.86 (377.4)	—	—	160.0 (72.6)

Note

① Center mounting slot at bottom supplied only on Size 00 and 0 contactors.

Approximate Dimensions in Inches (mm)

Reversing Contactors—Open Type

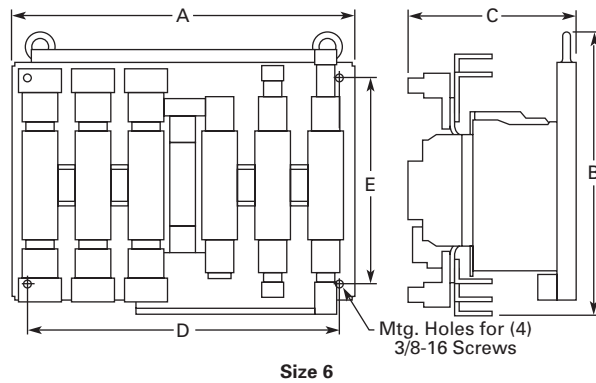
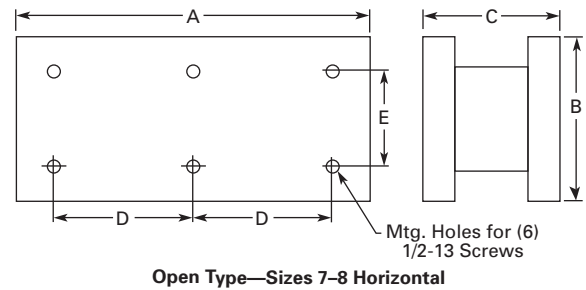
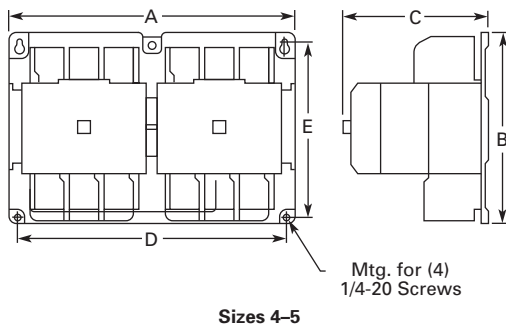
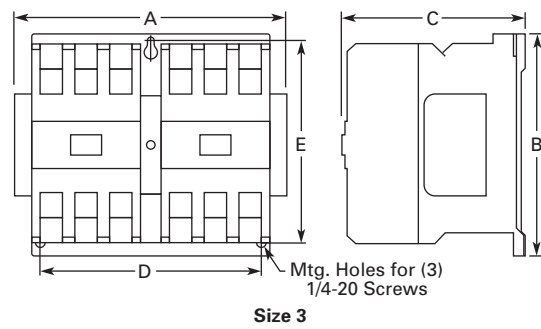
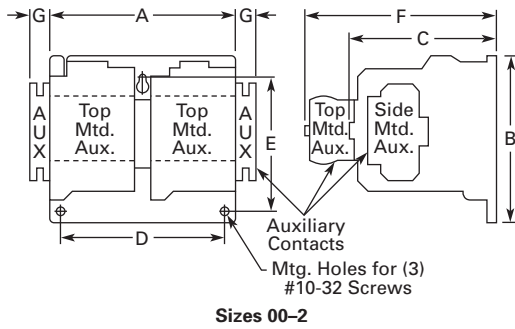

Dimensions and Shipping Weights

NEMA Size	Wide A	High B	Deep C	Mounting D	Mounting E	F	G	Shipping Weight Lbs (kg)
00-0	4.20 (106.7)	4.35 (110.5)	3.52 (89.4)	3.50 (88.9)	3.86 (98.0)	4.90 (124.5)	0.54 (13.7)	3.3 (1.5)
1-2	5.71 (145.0)	5.05 (128.3)	4.44 (112.8)	5.25 (133.4)	3.63 (92.2)	5.80 (147.3)	0.54 (13.7)	7.8 (3.5)
3	8.70 (221.0)	7.17 (182.1)	5.94 (150.9)	7.00 (177.8)	6.63 (168.4)	—	—	17.0 (7.7)
4	14.68 (372.9)	9.11 (231.4)	7.25 (184.2)	13.50 (342.9)	8.50 (215.9)	—	—	47.0 (21.3)
5	14.50 (368.3)	12.25 (311.2)	7.78 (197.6)	13.50 (342.9)	11.50 (292.1)	—	—	63.0 (28.6)
6	19.77 (502.2)	16.61 (421.9)	9.90 (251.5)	18.00 (457.2)	12.00 (304.8)	—	—	80.0 (36.3)
7	28.00 (711.2)	26.75 (679.5) ①	12.75 (323.9)	12.75 (323.9)	11.00 (279.4)	—	—	260.0 (118.0)
8	30.13 (765.3)	39.00 (990.6) ①	14.69 (373.1)	14.13 (358.9)	15.00 (381.0)	—	—	350.0 (158.9)

Note

① Includes cross wiring.

Three-Phase Non-Reversing and Reversing, Full Voltage Starters

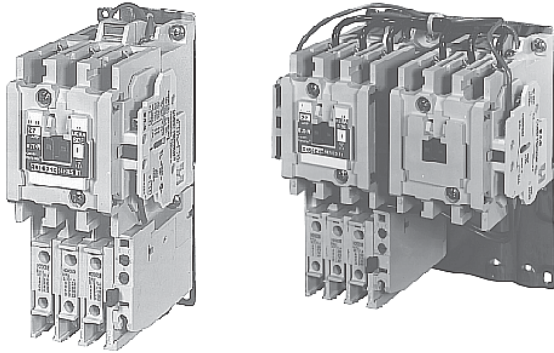

33

Contents

<i>Description</i>	<i>Page</i>
Contactors—Non-Reversing and Reversing	4
Starters—Three-Phase Non-Reversing and Reversing, Full Voltage	
Product Selection	11
Kits and Accessories	13
Renewal Parts Publication Numbers	13
Technical Data and Specifications	13
Wiring Diagrams	14
Starters—Single-Phase Non-Reversing, Full Voltage, Bi-Metallic Overload	15
Accessories	21
Renewal Parts	30
Technical Data and Specifications	35
Relays—Thermal Overload	39
C440/ <i>XT</i> Electronic Overload Relay	49

Starters—Three-Phase Non-Reversing and Reversing, Full Voltage

Product Description

Non-Reversing

Three-phase, full voltage magnetic starters are most commonly used to switch AC motor loads. Starters consist of a magnetically actuated switch (contactor) and an overload relay assembled together.

Reversing

Three-phase, full voltage magnetic starters are used primarily for reversing of three-phase squirrel cage motors. They consist of two contactors and a single overload relay assembled together. The contactors are mechanically and electrically interlocked to prevent line shorts and energization of both contactors simultaneously.

Features, Benefits and Functions

- Bimetallic ambient compensated overload relays—available in three basic sizes covering applications up to 900 hp—reducing number of different contactor/overload relay combinations that have to be stocked
These overload relays feature:
 - Selectable manual or automatic reset operation
 - Interchangeable heater packs adjustable $\pm 24\%$ to match motor FLA and calibrated for 1.0 and 1.15 service factors. Heater packs for smaller overload relay will mount in larger overload relay—useful in derating applications such as jogging
 - Load lugs built into relay base
 - Single-phase protection, Class 20 or Class 10 trip time
 - Overload trip indication
 - Electrically isolated NO-NC contacts (pull RESET button to test)
- The C440 is a self-powered, robust electronic overload designed for integrated use with Freedom NEMA contactors
 - Tiered feature set to provide coverage specific to your application
 - Broad 5: 1 FLA range for maximum flexibility
 - Coverage from 0.05–1500A to meet all your needs
- Long life twin break, silver cadmium oxide contacts—provide excellent conductivity and superior resistance to welding and arc erosion. Generously sized for low resistance and cool operation
- Designed to 3,000,000 electrical operations at maximum hp ratings up through 25 hp at 600V
- Steel mounting plate standard on all open type starters
- Wired for separate or common control

Non-Reversing

- Holding circuit contact(s) supplied as standard:
 - Sizes 00–3 have a NO auxiliary contact block mounted on right-hand side (on Size 00, contact occupies 4th power pole position—no increase in width)
 - Sizes 4–5 have a NO contact block mounted on left side
 - Sizes 6–7 have a 2NO/2NC contact block on top left
 - Size 8 has a NO/NC contact block on top left back and a NO on top right back

Reversing

- Each contactor (Size 00–8) supplied with one NO-NC side mounted contact block as standard. NC contacts are wired as electrical interlocks

Product Selection

When Ordering Supply

- Catalog number
- Heater pack number (see selection table, **Pages 41–43**) or full load current

Size 0 Non-Reversing Starter

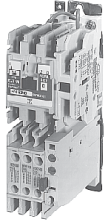

Size 1 Reversing Starter



Type AN16/AN56 NEMA—Manual or Automatic Reset Overload Relay—Non-Reversing and Reversing ①

NEMA Size	Continuous Ampere Rating	Service-Limit Current Rating (Amperes) ②	Maximum UL Horsepower ②						Three-Pole Non-Reversing ③ Catalog Number	Three-Pole Reversing ③ Catalog Number	Vertical Reversing ③ Catalog Number
			Single-Phase		Three-Phase						
			115V	230V	208V	240V	480V	600V			
00	9	11	1/3	1	1-1/2	1-1/2	2	2	AN16AN0_C	AN56AN0_C	—
0	18	21	1	2	3	3	5	5	AN16BN0_C	AN56BN0_C	AN56BNV0_
1	27	32	2	3	7-1/2	7-1/2	10	10	AN16DN0_B	AN56DN0_B	AN56DNV0_
2	45	52	3	7-1/2	10	15	25	25	AN16GN0_B	AN56GN0_B	AN56GNV0_
3	90	104	—	—	25	30	50	50	AN16KN0_	AN56KN0_	AN56KNV0_
4	135	156	—	—	40	50	100	100	AN16NN0_	AN56NN0_	AN56NNV0_
5	270	311	—	—	75	100	200	200	AN16SN0_B	AN56SN0_B	—
6	540	621	—	—	150	200	400	400	AN16TN0_C	AN56TN0_C	—
7	810	932	—	—	200	300	600	600	AN16UN0_B	AN56UN0_B	—
8 ⑤	1215	1400	—	—	400	450	900	900	AN16VN0_B	AN56VN0_B	—

Magnet Coils—AC or DC

Starter coils listed in this section also have a 50 Hz rating as shown in the adjacent table. Select required starter by catalog number and replace the magnet coil alpha designation

in the catalog number () with the proper code suffix from the table.

For Sizes 00–2 and 5–8, the magnet coil alpha designation will be the next to last digit of the listed catalog number.

EXAMPLE: For a 380V, 50 Hz coil, change AN16BN0_C to AN16BN0LC. For all other sizes, the magnet coil alpha designation will be the last digit of the listed catalog number.

For **DC Magnet Coils**, see Accessories, **Pages 28 and 29**.

AC Suffix

Coil Volts and Hertz	Code Suffix
120/60 or 110/50	A
240/60 or 220/50	B
480/60 or 440/50	C
600/60 or 550/50	D
208/60	E
277/60	H
208–240/60 ⑥	J
240/50	K

Coil Volts and Hertz	Code Suffix
380–415/50	L
550/50	N
24/60, 24/50 ⑦	T
24/50	U
32/50	V
48/60	W
48/50	Y
48/50	Y

Notes

① Starter catalog numbers do not include heater packs. Select one carton of three heater packs. Heater pack selection, **Pages 41–43**.

② Maximum horsepower rating of starters for 380V 50 Hz applications:

NEMA Size	00	0	1	2	3	4	5	6	7	8
Horsepower	1-1/2	5	10	25	50	75	150	300	600	900

③ Underscore () indicates coil suffix required, see AC Suffix table.

④ The service-limit current ratings represent the maximum rms current, in amperes, which the controller shall be permitted to carry for protracted periods in normal service. At service-limit current ratings, temperature rises shall be permitted to exceed those obtained by testing the controller at its continuous current rating. The current rating of overload relays or trip current of other motor protective devices used shall not exceed the service-limit current rating of the controller.

⑤ Common control. For separate 120V control, insert letter **D** in 7th position of listed catalog number. Example: AN56VND0CB.

⑥ NEMA Sizes 00 and 0 only.

⑦ NEMA Sizes 00 and 0 only. Sizes 1–8 are 24/60 only.

Two-Speed Selective Control

When Ordering Supply

- Catalog number plus magnet coil code suffix. Example: Size 0—AN700BN022B
- Heater pack number or full load current for each speed

For two-speed other than selective control:

- Catalog number plus magnet coil code suffix and option required. Example: AN700BN022B except compelling
- Heater pack number or full load current for each speed

Note: Two-speed starters are designed for starting and controlling both separate (two-winding) and reconnectable (one-winding) motors. Separate winding, WYE-WYE motors have a separate winding for each speed. Reconnectable, consequent pole motors use the same winding for both speeds. All standard starters are wired for selective control.

Two-Winding AN700DN022



Separate Winding ①

Maximum Horsepower—60/50 Hertz

Constant or Variable Torque

Constant or Variable Torque				Constant Horsepower				NEMA Size	Open Type Catalog Number
115V	200V	230V	460V/575V	115V	200V	230V	460/575V		
1-1/2	3	3	5	1	2	2	3	0	AN700BN022_
3	7-1/2	7-1/2	10	2	5	5	7-1/2	1	AN700DN022_
—	10	15	25	—	7-1/2	10	20	2	AN700GN022_
—	25	30	50	—	20	25	40	3	AN700KN022_
—	40	50	100	—	30	40	75	4	AN700NN022_
—	75	100	200	—	60	75	150	5	AN700SN022_

Prices of starters do not include heater packs. Select two packs (two overload relays, one for each speed). Heater pack selection, Pages 41–43.

One-Winding AN700BN0218



Reconnectable Winding ①

Maximum Horsepower—60/50 Hertz

Constant or Variable Torque

Constant or Variable Torque				Constant Horsepower				NEMA Size	Open Type Constant or Variable Torque Catalog Number	Constant Horsepower Catalog Number
115V	200V	230V	460V/575V	115V	200V	230V	460/575V			
1-1/2	3	3	5	1	2	2	3	0	AN700BN0218_	AN700BN0219_
3	7-1/2	7-1/2	10	2	5	5	7-1/2	1	AN700DN0218_	AN700DN0219_
—	10	15	25	—	7-1/2	10	20	2	AN700GN0218_	AN700GN0219_
—	25	30	50	—	20	25	40	3	AN700KN0218_	AN700KN0219_
—	40	50	100	—	30	40	75	4	AN700NN0218_	AN700NN0219_

Prices of starters do not include heater packs. Select two packs (two overload relays, one for each speed). Heater pack selection, Pages 41–43.

One-Winding AN700DN0218



Magnetic Coils—AC or DC

Coil Voltage and Hz	Code Suffix	Coil Voltage and Hz	Code Suffix	Coil Voltage and Hz	Code Suffix
120/60 or 110/50	A	277/60	H	24/60, 24/50 ②	T
240/60 or 220/50	B	208–240/60	J	24/50	U
480/60 or 440/50	C	240/50	K	32/50	V
600/60 or 550/50	D	380–415/50	L	48/60	W
208/60	E	550/50	N	48/50	Y

Notes

- ① If branch circuit protective device is 45A or greater, C320FBR1 fuse kit(s) may be required for circuit protection per NEC 530-072.
- ② NEMA Sizes 00 and 0 only. Sizes 1–5 are 24/60 only.

Kits and Accessories

- Auxiliary contacts, contactor mounted—**Pages 25–27**
- Transient suppressor, for magnet coil—**Page 24**
- Timers—solid-state and pneumatic, mount on contactor—**Page 22**

Renewal Parts**Publication Numbers**

- See **Page 30**

Technical Data and Specifications**Wire (75°C) Sizes—AWG or kcmil—NEMA Sizes 00–2—Open and Enclosed**

NEMA Size	Wire Size ^① Cu Only
Power Terminals—Line	
00	12–16 AWG stranded, 12–14 AWG solid
0	8–16 AWG stranded, 10–14 AWG solid
1	8–14 AWG stranded or solid
2	3–14 AWG (upper) and/or 6–14 AWG (lower) stranded or solid ^②
Power Terminals—Load—Cu Only (stranded or solid)	
00–0	14–6 AWG stranded or solid
1–2	14–2 AWG stranded or solid
Control Terminals—Cu Only	
12–16 AWG stranded, 12–14 AWG solid	

Wire (75°C) Sizes—AWG or kcmil—NEMA Sizes 3–8—Open and Enclosed

NEMA Size	Wire Size ^②
Power Terminals—Line and Load	
3	1/0–14 AWG Cu/Al
4	Open—3/0–8 AWG Cu; Enclosed—250 kcmil—6 AWG Cu/Al
5	750 kcmil—2 AWG; or (2) 250 kcmil—3/0 AWG Cu/Al
6	(2) 750 kcmil—3/0 AWG Cu/Al
7	(3) 750 kcmil—3/0 AWG Cu/Al
8	(4) 750 kcmil—1/0 AWG Cu/Al
Control Terminals—Cu Only	
12–16 AWG stranded, 12–14 AWG solid	

Plugging and Jogging Service Horsepower Ratings ^③

NEMA Size	200V	230V	460V	575V
00	—	1/2	1/2	1/2
0	1-1/2	1-1/2	2	2
1	3	3	5	5
2	7-1/2	10	15	15
3	15	20	30	30
4	25	30	60	60
5	60	75	150	150
6	125	150	300	300

Notes

- ^① Minimum per NEC. Maximum wire size: Sizes 00 and 0 to 8 AWG and Sizes 1–2 to 2 AWG.
^② Two compartment box lug.
^③ Maximum horsepower where operation is interrupted more than 5 times per minute, or more than 10 times in a 10 minute period. NEMA Standard ICS2-1993 table 2-4-3.

33.1

NEMA Contactors and Starters

Freedom Series

Wiring Diagrams

Three-Phase and Single-Phase Applications

33

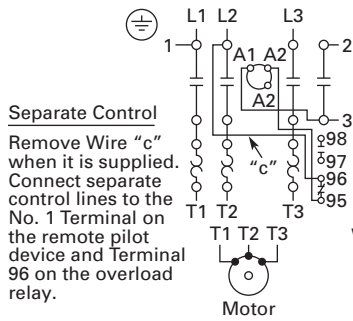

Remote Pilot Devices

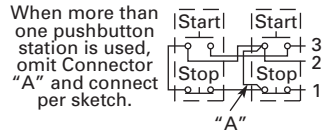
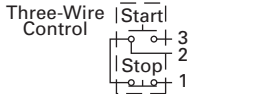
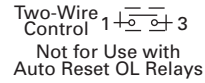

NEMA Size 00

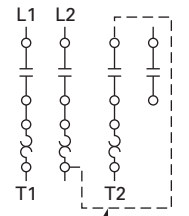

Field Conversion to Single-Phase, Add Dotted Connections

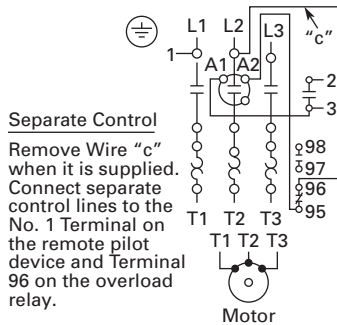

Remote Pilot Devices

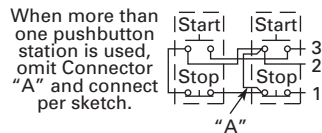
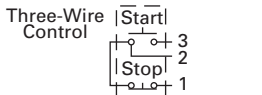
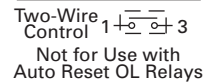

NEMA Sizes 0, 1 and 2

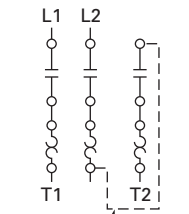

Field Conversion to Single-Phase, Add Dotted Connections



NEMA Size 1—BN15DN0AB

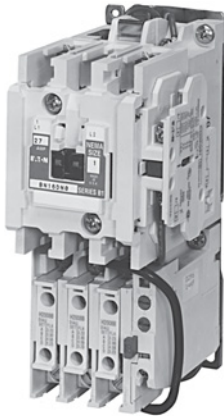

Contents

<i>Description</i>	<i>Page</i>
Contactors—Non-Reversing and Reversing	4
Starters—Three-Phase Non-Reversing and Reversing, Full Voltage	10
Starters—Single-Phase Non-Reversing, Full Voltage, Bi-Metallic Overload	
Product Selection	16
Wiring Diagrams	16
Dimensions	17
Accessories	21
Renewal Parts	30
Technical Data and Specifications	35
Relays—Thermal Overload	39
C440/ <i>XT</i> Electronic Overload Relay	49

Starters—Single-Phase Non-Reversing, Full Voltage, Bi-Metallic Overload

Product Description

Single-phase, full voltage magnetic starters connect the motor directly across the line, allowing it to draw full inrush current during start-up. These starters are most commonly used for control of self-starting single-phase motors up to 15 hp at 230V. They consist of a two-pole electromagnetic contactor to make and break the motor power circuit and an overload relay to provide running overload protection. Starters listed in the table include:

- Two-pole Freedom Series contactor with long life twin break, silver cadmium oxide contacts. Generously sized for low resistance and cool operation. Designed to 3 million electrical operations at maximum hp and 30 million mechanical operations to Size 0, 10 million operations to Size 2 and 6 million operations to Size 3
- Three-pole Freedom Series overload with poles two and three wired in series for motor overload protection. This overload is ambient compensated, selectable manual or automatic reset, interchangeable Class 10 or 20 heater packs, 1.0 or 1.15 service factor selectability, overload trip indication and electrically isolated NO-NC contacts (pull RESET button to test)
- Holding circuit NO auxiliary contact supplied as standard. On Size 00, the contact occupies the 4th power pole position. Sizes 0–3 have the NO auxiliary mounted on the right side of the contactor
- Steel mounting plate as standard on all open type starters. Wired for separate or common control

33.1

NEMA Contactors and Starters

Freedom Series

Product Selection

When Ordering Specify

- Catalog number
- Heater pack number (see selection table, **Pages 41–43**) or full load current

33

BN16DM0AB



Type BN16 NEMA—Manual or Automatic Reset Overload Relay

NEMA Size	Maximum Horsepower		Magnet Coil Voltage (60 Hz)	Open Type Two-Pole Catalog Number
	Motor Voltage	Single-Phase		
00	115	1/3	120 ①	BN16AN0AC
	230	1	240	BN16AN0BC
0	115	1	120 ①	BN16BN0AC
	230	2	240	BN16BN0BC
1	115	2	120 ①	BN16DN0AB
	230	3	240	BN16DN0BB
1P	115	3	120 ①	BN16PN0AB
	230	5	240	BN16PN0BB
2	115	3	120 ①	BN16GN0AB
	230	7-1/2	240	BN16GN0BB
3	115	7-1/2	120 ①	BN16KN0A
	230	15	240	BN16KN0B

Starter catalog numbers do not include heater packs. Select one carton of three heater packs. Heater pack selection, **Pages 41–43**.

Notes

- ① For separate 120V control circuit. For maximum hp at listed motor voltages, use the rating of other starters of same size.

Wiring Diagrams

Single-Phase Applications (Factory Wired)

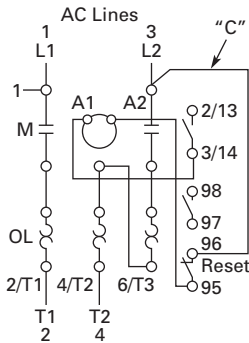

Separate Control

Remove Wire "C" if supplied and connect separate control lines to the Number 1 Terminal on the remote pilot device and to the Number 96 Terminal on the overload relay.

Front View of Panel



Single-Phase Motor

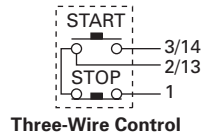
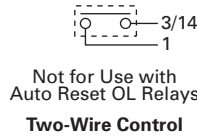

When more than one pushbutton station is used, omit Connector "A" and connect per sketch at right.

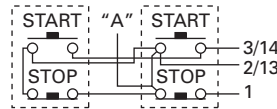

Dimensions

Approximate Dimensions in Inches (mm)

Non-Reversing Starters, Bi-Metallic Overload—Open Type

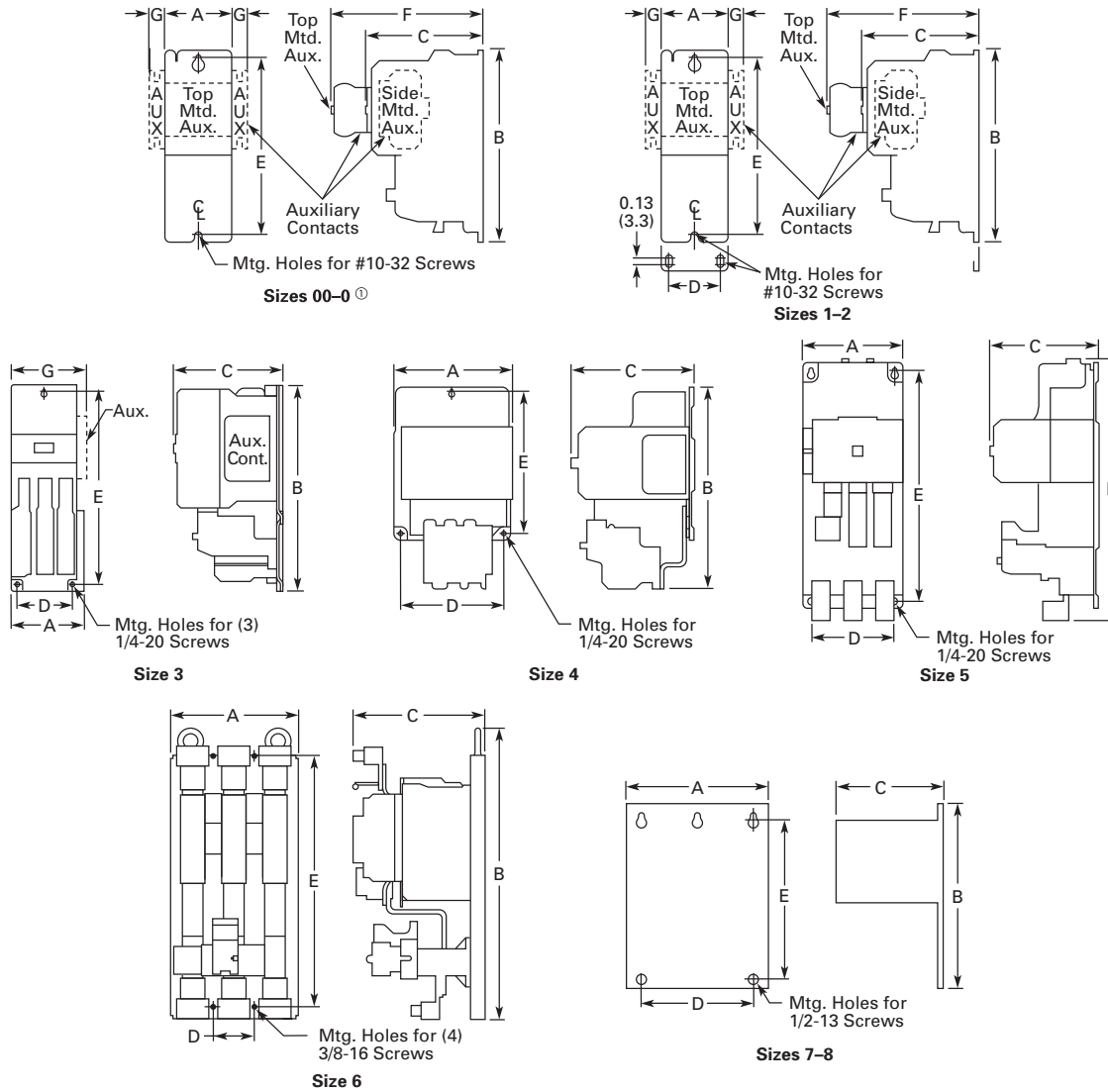

Dimensions and Shipping Weights

NEMA Size	Wide A	High B	Deep C	Mounting D	Mounting E	F	G	Shipping Weight Lbs (kg)
00-0	1.80 (45.7)	6.60 (167.6)	3.52 (89.4)	—	6.07 (154.2)	4.90 (124.5)	0.54 (13.7)	2.2 (1.0)
1-1P	2.56 (65.0)	7.08 (179.8)	4.44 (112.8)	2.00 (50.8)	6.63 (168.4)	5.80 (147.3)	0.54 (13.7)	4.5 (2.0)
2	2.56 (65.0)	8.08 (205.2)	4.44 (112.8)	2.00 (50.8)	7.63 (193.8)	5.80 (147.3)	0.54 (13.7)	4.7 (2.1)
3	4.08 (103.6)	11.35 (288.3)	5.94 (150.9)	3.00 (76.2)	10.81 (274.6)	—	—	11.0 (5.0)
4	7.05 (179.1)	12.06 (306.3)	7.25 (184.2)	6.00 (152.4)	8.50 (215.9)	—	—	23.0 (10.4)
5	7.00 (177.8)	17.77 (451.4)	7.76 (197.1)	6.00 (152.4)	16.00 (406.4)	—	—	36.0 (16.3)
6	9.47 (240.5)	21.69 (550.9)	9.90 (251.5)	3.10 (78.7)	18.00 (457.2)	—	—	75.0 (34.1)
7	15.13 (384.3)	29.13 (739.9)	12.64 (321.1)	13.25 (336.6)	21.25 (539.8)	—	—	120.0 (54.5)
8	15.13 (384.3)	34.50 (876.3)	15.00 (381.0)	13.25 (336.6)	16.75 (425.5)	—	—	210.0 (95.3)

Note

Ⓢ Holding circuit contact for Size 00 occupies 4th power pole position—no increase in width.

33.1 NEMA Contactors and Starters

Freedom Series

Approximate Dimensions in Inches (mm)

Reversing Starters, Bi-Metallic Overload—Open Type

33

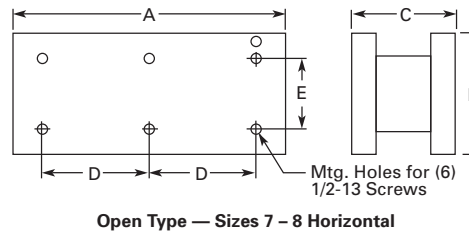
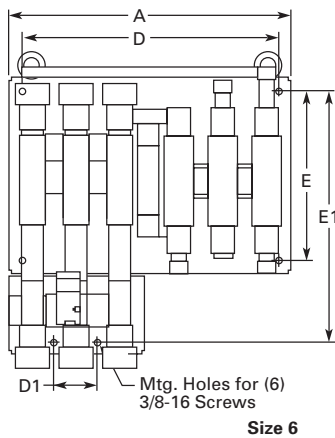
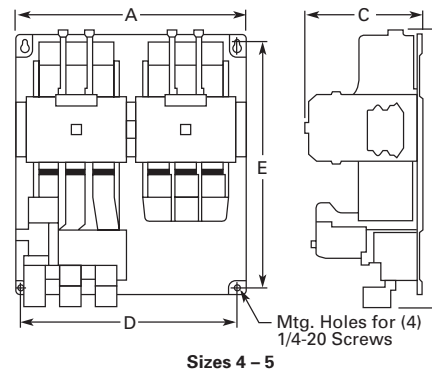
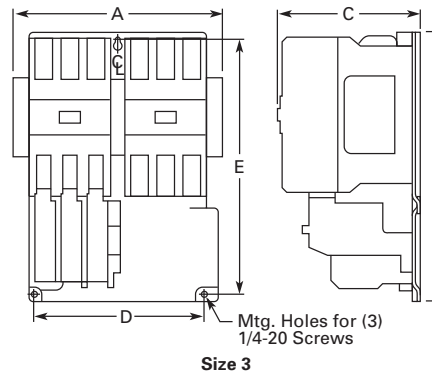
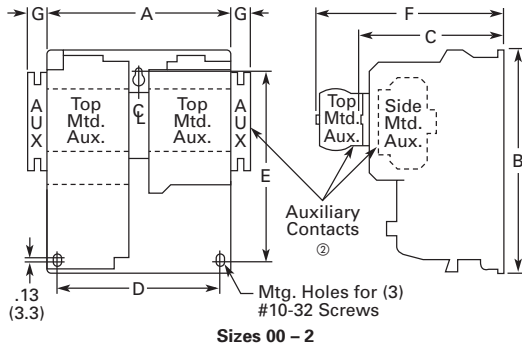

Dimensions and Shipping Weights

NEMA Size	Wide A	High B	Deep C	Mounting D	Mounting E	D1	E1	F	G	Shipping Weight Lbs (kg)
00-0	4.20 (106.7)	7.38 (187.5)	3.52 (89.4)	3.50 (88.9)	6.87 (174.5)	—	—	4.90 (124.5)	0.54 (13.7)	3.6 (1.6)
1	5.71 (145.0)	7.08 (179.8)	4.44 (112.8)	5.25 (133.4)	5.75 (146.1)	—	—	5.80 (147.3)	0.54 (13.7)	8.3 (3.8)
2	5.71 (145.0)	8.08 (205.2)	4.44 (112.8)	5.25 (133.4)	6.75 (171.5)	—	—	5.80 (147.3)	0.54 (13.7)	8.5 (3.9)
3	8.70 (221.0)	11.35 (288.3)	5.94 (150.9)	7.00 (177.8)	10.81 (274.6)	—	—	—	—	20.0 (9.1)
4	14.68 (372.9)	12.06 (306.3)	7.25 (184.2)	13.50 (342.9)	8.50 (215.9)	—	—	—	—	49.0 (22.2)
5	14.50 (368.3)	17.77 (451.4)	7.76 (197.1)	13.50 (342.9)	16.00 (406.4)	—	—	—	—	68.0 (30.9)
6	19.77 (502.2)	22.63 (574.8)	9.90 (251.5)	18.00 (457.2)	12.00 (304.8)	3.10 (78.7)	18.00 (457.2)	—	—	90.0 (40.9)
7	28.06 (712.7)	32.13 (816.1) ①	12.70 (322.6)	12.75 (323.9)	21.25 (539.8)	—	—	—	—	175.0 (79.5)
8	30.38 (771.7)	41.50 (1054.1) ①	14.70 (373.4)	14.13 (358.9)	16.75 (425.5)	—	—	—	—	430.0 (195.2)

Notes

- ① Includes cross wiring overhang.
- ② See catalog listings for type and location of auxiliary contacts supplied with a particular starter.

Approximate Dimensions in Inches (mm)

Reversing Starters—Vertical Construction, Bi-Metallic Overload—AN56V Open Vertical Starter

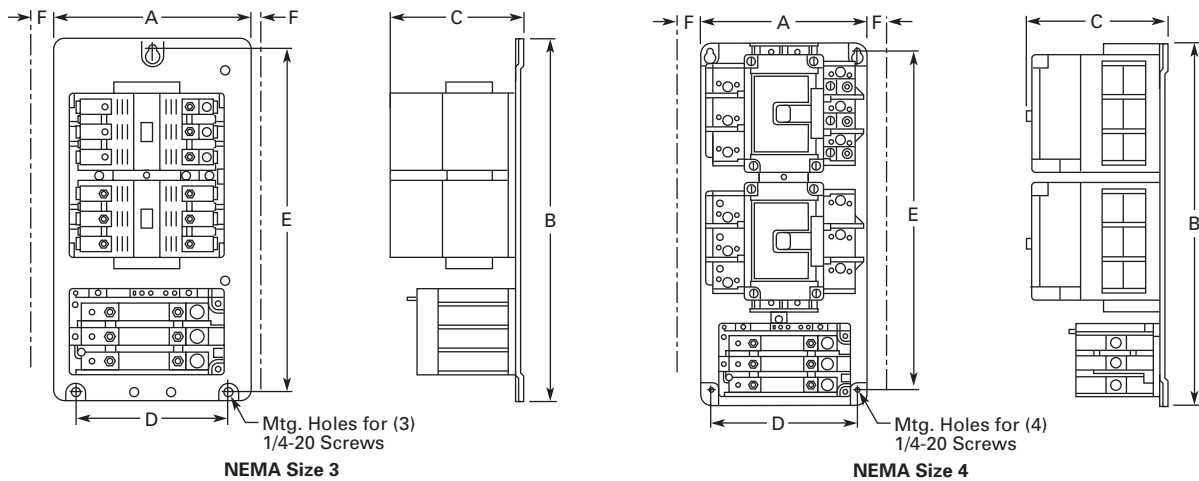
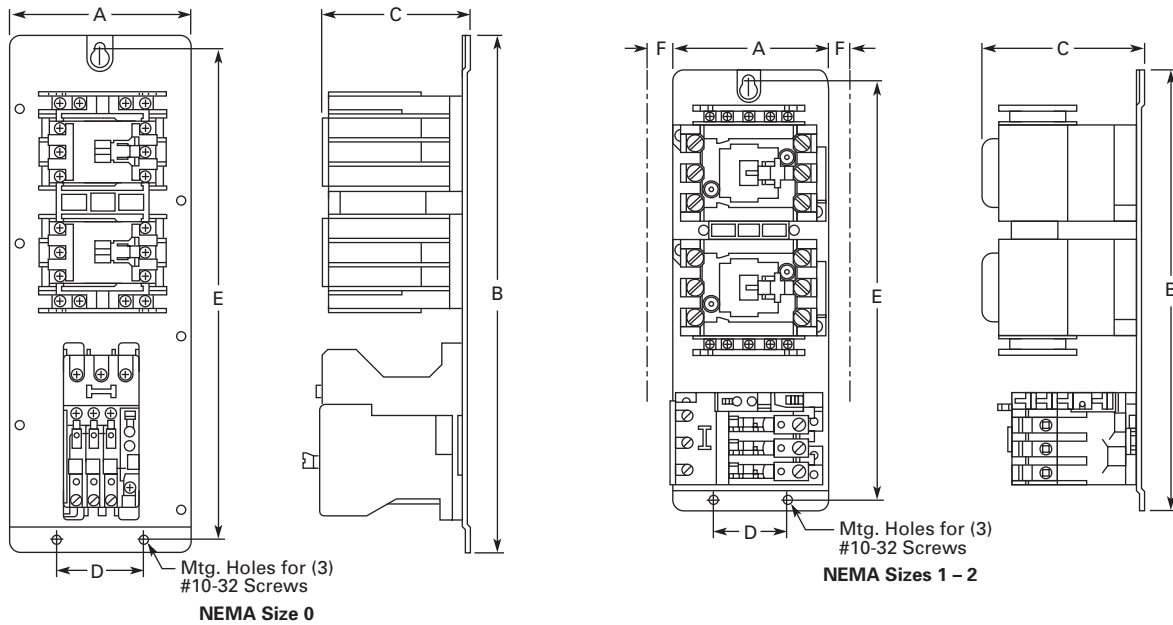

Dimensions and Shipping Weights

NEMA Size	Wide A	High B	Deep C	Mounting Wide D	Mounting High E	Wire Zone	Shipping Weight Lbs (kg)
0	4.25 (108.0)	12.05 (306.1)	3.84 (97.5)	2.00 (50.8)	11.50 (292.1)	—	4.0 (1.8)
1	4.25 (108.0)	12.05 (306.1)	3.86 (98.0)	2.00 (50.8)	11.50 (292.1)	1.00 (25.4)	9.0 (4.1)
2	4.25 (108.0)	12.05 (306.1)	3.86 (98.0)	2.00 (50.8)	11.50 (292.1)	1.00 (25.4)	9.5 (4.3)
3	9.25 (235.0)	16.75 (425.5)	5.18 (131.6)	7.15 (181.6)	16.07 (408.2)	①	21.0 (9.5)
4	9.08 (230.6)	19.84 (503.9)	5.18 (131.6)	8.00 (203.2)	18.51 (470.2)	1.50 (38.1)	50.0 (22.7)

Note

① Wire overhang 1.00 mm left, 50 mm right.

33.1 NEMA Contactors and Starters

Freedom Series

Approximate Dimensions in Inches (mm)

Multispeed Starters, Bi-Metallic Overload—AN700 Open Vertical Starter

33

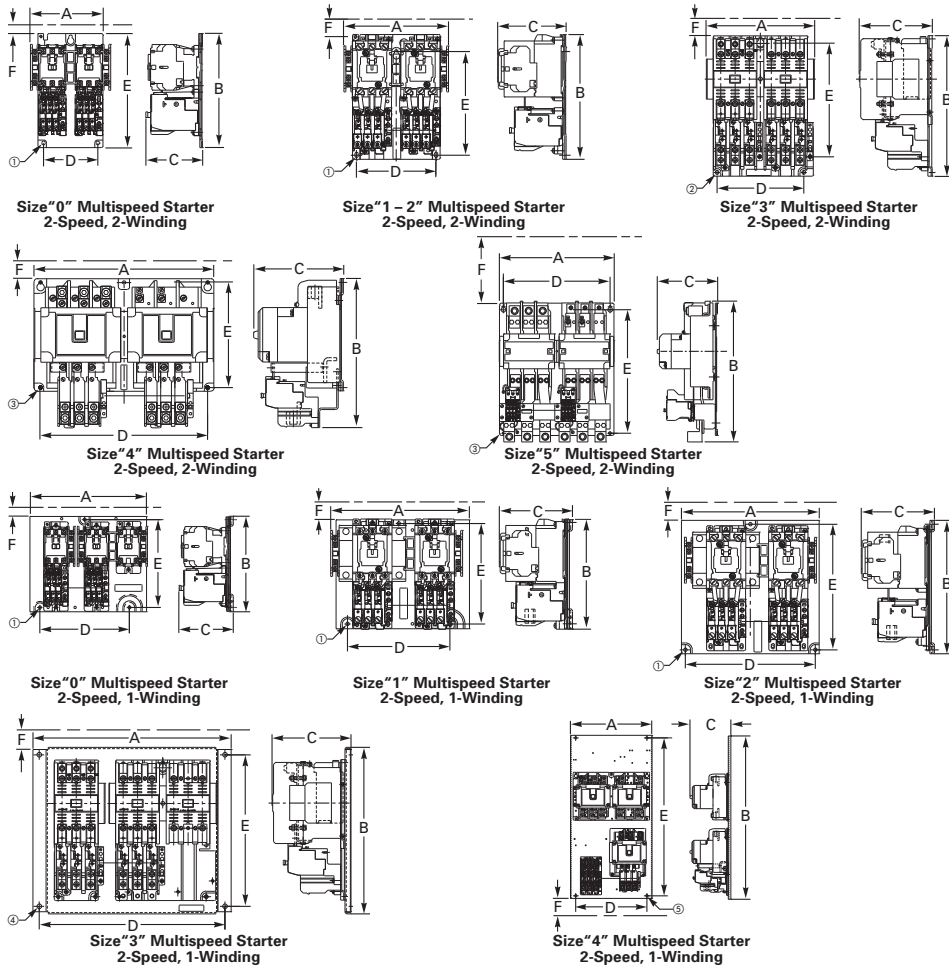

Dimensions and Shipping Weights

NEMA Size	Wide A	High B	Deep C	Mounting Wide D	Mounting High E	Wire Zone F	Shipping Weight Lbs (kg)
Two-Speed—Selective Control—Separate Winding							
0	5.19 (132)	7.38 (188)	3.52 (89)	3.50 (89)	6.87 (175)	0.89 (23)	4.5 (2.0)
1	5.66 (144)	7.08 (180)	4.42 (112)	5.25 (133)	5.75 (146)	1.23 (31)	9.0 (4.1)
2	5.66 (144)	8.08 (205)	4.42 (112)	5.25 (133)	6.75 (165)	1.63 (41)	10.0 (4.5)
3	8.72 (221)	11.35 (288)	5.89 (150)	7.00 (178)	10.81 (275)	1.77 (45)	24.0 (10.9)
4	14.68 (373)	12.06 (306)	7.25 (184)	13.50 (343)	8.50 (216)	1.95 (50)	53.0 (24.1)
5	14.50 (368)	17.82 (453)	7.76 (197)	13.50 (343)	16.00 (406)	4.56 (116)	73.0 (33.1)
Two-Speed—Selective Control—Reconnectable Winding							
0	8.62 (219)	7.06 (179)	3.82 (81)	6.62 (168)	6.50 (165)	0.50 (13)	6.0 (2.7)
1	8.97 (228)	7.12 (181)	4.72 (120)	6.62 (168)	6.50 (165)	1.04 (26)	10.0 (4.5)
2	8.90 (226)	8.62 (219)	4.75 (121)	8.40 (213)	8.12 (206)	1.03 (26)	11.0 (5.0)
3	16.00 (406)	13.46 (342)	6.38 (162)	15.00 (381)	12.25 (311)	1.24 (31)	31.0 (14.1)
4	15.46 (393)	31.00 (787)	7.74 (197)	13.50 (343)	30.00 (762)	1.84 (47)	72.0 (32.7)

Notes

- ① Mounting holes for (3) #10 screws.
- ② Mounting holes for (3) 1/4-20 screws.
- ③ Mounting holes for (4) 1/4-20 screws.
- ④ Mounting holes for (4) 5/16 screws.
- ⑤ Mounting holes for (4) 3/8 screws.

Accessories

Three-Pole Top Mounted Fuse Block Kit

IEC Sizes A–K, NEMA Sizes 00–2

Field mount to Freedom Series starters and contactors. Designed to save space and

reduce installation costs. They provide short circuit protection for branch circuits.

Mounted Fuse Block Kit

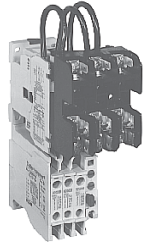

Fuse Block Kits

Fuse Type	Catalog Number
Class H—30A 250V	C350KH21
Class R—30A 250V	C350KR21
Class G—15A 300V	C350KG37
Class G—20A 300V	C350KG38
Class G—30A 300V	C350KG31
Class G—60A 300V	C350KG32
Class T—30A 300V	C350KT31
Class T—60A 300V	C350KT32
Class J—30A 600V	C350KJ61
Class J—60A 600V	C350KJ62
Type M—30A 600V ①	C350KM61
Class CC—30A 600V	C350KC63
Class T—30A 600V	C350KT61
Class T—60A 600V	C350KT62

Three-Pole Top Mounted Fuse Block Kit

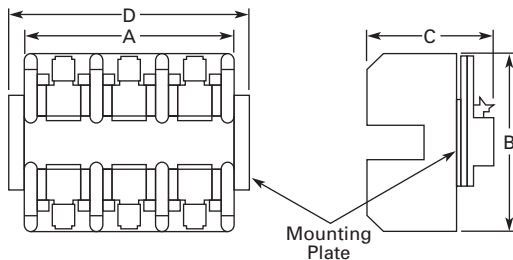

Fuse Block Class	Amperes	Volts	Approximate Dimensions in Inches (mm)			
			Wide A	High B	Deep C	D
G	15, 20, 30 60	300	2.40 (61.0)	3.00 (76.2)	2.04 (51.8)	—
		300	2.62 (66.5)	4.25 (108.0)	2.08 (52.8)	—
H	30	250	3.00 (76.2)	3.10 (78.7)	2.23 (56.6)	3.62 (91.9)
J	30, 60	600	4.81 (122.2)	4.12 (104.6)	2.82 (71.6)	—
M, CC	30	600	2.40 (61.0)	3.00 (76.2)	2.04 (51.8)	—
R	30	250	3.00 (76.2)	3.10 (78.7)	2.23 (56.6)	3.62 (91.9)
T	30, 60	300	3.44 (87.4)	3.00 (76.2)	2.33 (59.2)	—
		600	3.75 (95.3)	3.31 (84.1)	2.26 (57.4)	—
	60	600	4.87 (123.7)	3.00 (76.2)	2.58 (65.5)	—

Mechanical Interlock and Reversing Kits

Mechanical interlocks and reversing kits are designed for field assembly of reversing contactors or starters from Freedom Series components. The reversing kits include a mechanical

interlock, stabilizer bar and a pre-cut, trimmed and formed wire set. Auxiliary contacts, if required, must be ordered separately. See **Pages 25 and 26**.

C321KM60B

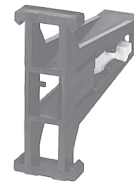

Part No. 23-7165



Wire Set



Mechanical Interlock Only ②③

Application			
NEMA Size	IEC Size	Contactor Mounting	Catalog Number
00–2	A–K	Horizontal	C321KM60B
3	L–N	Horizontal	C321KM30
3 to 4	N to P	Horizontal	C321KM43
4	P–S	Horizontal	C321KM40
4 to 5	—	Horizontal	C321KM45
4 to 6	S to T/U	Horizontal	C321KM80
5	—	Horizontal	C321KM50
5 to 6	—	Horizontal	C321KM56
6	T and U	Horizontal	C321KM70
6 to 7	T/U to V–X	Horizontal	C321KM90
7	V, W and X	Horizontal	C321KM34
4 or 5 to 5	P–S to 5	Vertical	C321KM55
5 to 6	—	Vertical	C321KM65
6	T and U	Vertical	C321KM66
6 to 7	T/U to V–X	Vertical	C321KM67

Reversing Kits (Horizontal Contactor Mounting Only)

Application		
NEMA Size	IEC Size	Catalog Number
00	A–C	C321KM60K14B
0	D–F	C321KM60K13B
1	—	C321KM60K15B
2	G–K	C321KM60K16B
3	—	C321KM60K17 ④
—	L and M	C321KM60K21 ④
—	N	C321KM60K18 ④
4	—	C321KM60K19 ④
5	—	C321KM60K20 ④
—	P–S	C321KM60K44 ④

Notes

- ① Type M fuse block not approved for branch circuit protection.
- ② Without cross-wiring.
- ③ For use with latest series product.
- ④ Kit includes (2) NC auxiliary contacts.

33.1

NEMA Contactors and Starters

Freedom Series

33

Solid-State Timers

Solid-State ON DELAY Timer—Side Mounted on Freedom Series NEMA 00–2, IEC A–K and C25D, C25E and C25F Frame

This timer is designed to be **wired in series with the load** (typically a coil). When the START button is pushed (power applied to timer), the

ON DELAY timing function starts. At the completion of the set timing period, timer and series wired load will both be energized.

Solid-State Timer



Mounted Timer Product Selection

Timing Range	Catalog Number ^{①②③}
0.1–1.0 seconds	C320TDN1_
1–30 seconds	C320TDN30_
30–300 seconds	C320TDN300_
5–30 minutes	C320TDN3000_

Shorting Bar Kits

These kits provide phase-to-phase power connections of contactors for field assembly. The kits include bus

connections and mounting hardware. The shorting bars connect all three phases of a single contactor.

Shorting Bar Kits

Description	Catalog Number
NEMA Size 3, IEC Sizes L–N	C321SB18
NEMA Size 4, IEC Sizes A–S	C321SB19
NEMA Size 6, IEC Sizes T and U	C321SB22

Pneumatic Timers—Top Mounted

Attachment mounts on top of any NEMA Size 00–2 or IEC Size A–K Freedom Series starter or contactor (top mounted auxiliary contacts cannot be installed on device when timer is used). Timer

unit has 1NO-1NC isolated timed contacts—circuits in each pole must be the same polarity. Units are convertible from OFF to ON DELAY or vice-versa.

Pneumatic Timers



Pneumatic Timers

Timing Range	Catalog Number
0.1 to 30 seconds	C320TP1
10 to 180 seconds	C320TP2

Maximum Ampere Ratings

Description	Vac			
	120	240	480	600
Make	30	15	7.5	6
Break	3	1.5	0.75	0.6

Locking Cover for Overload Relay—C306 Only

Snap-on transparent or opaque plastic panel for covering access port to the overload relay trip setting

dial—helps prevent accidental or unauthorized changes to trip and reset setting.

Locking Cover for Overlay Relay



Locking Cover for Overlay Relay

Description	Min. Ordering Quantity (Std. Pkg.)	Catalog Number
Clear cover, no accessibility	50	C320PC3
Gray cover, no accessibility, with Auto only nib	50	C320PC4
Gray cover, no accessibility, with Manual only nib	50	C320PC5
Gray cover with FLA dial accessibility, A, B, C, D positions and Auto only nib	50	C320PC6
Gray cover with FLA dial accessibility, A, B, C, D positions and Manual only nib	50	C320PC7

Notes

- ① Add operating voltage suffix to catalog number.
A = 120V, **B** = 240V, **E** = 208V
- ② Rated 0.5 ampere pilot duty—not to be used on larger contactors.
- ③ Terminal connections are quick connects only. Two per side.

Identification Markers

IEC Sizes A–K, NEMA Sizes 00–2

Designed to snap on the face of individual devices. Includes holder and labels. personalized identification of

Identification Markers

Description	Catalog Number
Identification marker	C320DL2

Control Circuit Fuse Block

These panel mounted fuse holders, designed for control circuit protection or other similar low current requirements, have extractor type fuse caps. The Class CC rejection type fuses (KTK-R) used in these holders are intended for use with equipment designated as being suitable for use on systems having high available fault currents. If branch circuit protective device is 45A or greater, C320FBR fuse kit may be required for control circuit protection per NEC 430-72.

Control Circuit Fuse Block



Control Circuit Fuse Block

Type	Max. Amperes	Catalog Number
Fuse holder only	15	C320FB ①
	30	C320FBR ②

Dimensions

Approximate Dimensions in Inches (mm)

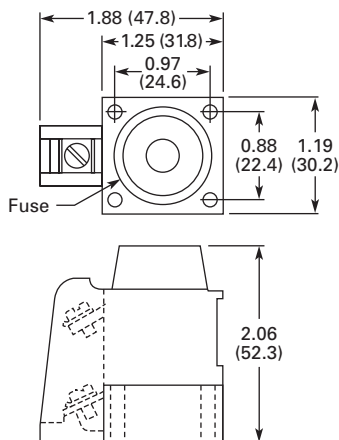

DIN Rail Mounting Channel—35 mm

Designed for DIN rail mounting of IEC style contactors and starters.

DIN Rail



DIN Rail

Description	Catalog Number
1 meter length	MC382MA1

Finger Protection Shields

Snap-on shields for both contactors and starters provide IEC Type IP20 finger protection. Prevents accidental contact with line/load terminals.

Finger Protection Shields

Application	Catalog Number
NEMA Size 00, IEC Sizes A–C	C320LS1
NEMA Size 0, IEC Sizes D–F	C320LS2
NEMA Sizes 1–2, IEC Sizes G–K	
Contactors	C320LS3
Reversing contactors	C320LS4
NEMA Size 1	
Starters	C320LS5
Reversing starters	C320LS6
NEMA Size 2, IEC Sizes G–K	
Starters	C320LS7
Reversing starters	C320LS8

Adapter to DIN Rail Mount

NEMA 1–2 and IEC G–K Contactors

Designed to allow DIN rail mounting of NEMA 1–2 and IEC G–K contactors. Includes all hardware required to convert contactors from panel mounting to 35 mm DIN rail mounting.

Adapter to DIN Rail Mount

Catalog Number
C320DN65

Notes

- ① A fuse is not supplied, but holder will accept a Bussman Type KTK or KTK-R (13/32 in x 1-1/2 in) fuse, 600V maximum.
- ② Includes a 5A, 600V KTK-R fuse.

33.1

NEMA Contactors and Starters

Freedom Series

33

Transient Suppressor Kits

NEMA Sizes 00–2, IEC Sizes A–K

These kits limit high voltage transients produced in the control circuit when power is removed from the contactor or starter coil. There are three separate suppressors for use on 24–120V, 208–240V or 277–480V coils respectively.

These devices mount directly to the coil terminals of Freedom Series contactors or starters NEMA Sizes 00–2, IEC Sizes A–K and lighting contactors 10–60A. Reversing devices will require two.

C320TS2



NEMA Sizes 00–2, IEC Sizes A–K

Description	Coil Voltage ①	Catalog Number
Transient suppressor	24/120V	C320TS1
	208/240V	C320TS2
	277/480V	C320TS3

NEMA Sizes 3–5, IEC Sizes L–S

This device mounts on top of any side mounted auxiliary contact on Freedom Series NEMA Sizes 3–5, IEC Sizes L–S and lighting contactors 100–300A. It connects across coil terminals on any 120V contactor or starter magnet

coil (reversing starters or contactors require 2).

Limits high voltage transients produced in the circuit when power is removed from the coil.

C320AS1



NEMA Sizes 3–5, IEC Sizes L–S

Description	Coil Voltage	Catalog Number
Transient suppressor	120V	C320AS1

Add-On Power Pole Kit

NEMA Sizes 00–2, IEC A–K

This device mounts on the side of Freedom NEMA Size 00–2 and IEC Size A–K contactors. One unit can be mounted on each side and

carries UL, cUL and IEC ratings. The device is rated for resistive, inductive and lighting applications.

NEMA Sizes 00–2, IEC A–K

UL Ampere Rating				IEC 947 Ampere Rating					
Inductive 600V	Resistive 600V	Horsepower Single-Phase		Locked Rotor 240V	Lighting Ballast Tungsten 480V	AC-1 600V	AC-3 600V	AC-5a AC-5b 480V	1NO Power Pole Catalog Number
		115V	230V						
15	20	1/2	2	96	20	20	12	18	C320PPD10

Note

① Suppressor is compatible with coil voltages/ranges as shown, both 50 and 60 Hz.

Adhesive Dust Cover

NEMA Sizes 00–2, IEC Sizes A–K

These adhesive stickers come 25 to a package and provide extra protection from contaminants when applied to the sides of Freedom NEMA Sizes 00–2 and IEC

Sizes A–K. Adhesive covers are easily applied to side opening where auxiliaries are not installed and provide extra protection from metal filings and other debris.

NEMA Sizes 00–2, IEC Sizes A–K

Description	Catalog Number
25 to a package	C320DSTCVR

Auxiliary Contacts

Contact Configuration Code



This two-digit code is found on the auxiliary contact to assist in identifying the specific contact configuration. The first digit indicates the quantity of NO contacts and the second indicates the quantity of NC contacts.

NEMA Sizes 00–2—IEC Sizes A–K

The auxiliary contacts listed on this page are designed for installation on Freedom Series starters and contactors. Snap-on design facilitates quick, easy installation.

These bifurcated design contact blocks, featuring silver cadmium alloy contacts, are well suited for use in very low energy (logic level) circuits.

NEMA Sizes 00–2—IEC Sizes A–K ①

	Description	Contact Configuration Code ②	Catalog Number
Side Mounted 	Side Mounted		
	1NO	10	C320KGS1
	1NC	01	C320KGS2
	1NO-1NC	11	C320KGS3
	2NO	20	C320KGS4
	2NC	02	C320KGS5
	1NO-1NCI	N/A	C320KGS6
	1NO (EC)-1NC (LO)	N/A	C320KGS7
1NCI	N/A	C320KGS8	
Top Mounted 	Top Mounted		
	1NO	10	C320KGT1
	1NC	01	C320KGT2
	1NO-1NC	11	C320KGT3
	2NO	20	C320KGT4
	2NC	02	C320KGT5
	1NO-1NCI	N/A	C320KGT6
	1NO (EC)-1NC (LO)	N/A	C320KGT7
	1NCI	N/A	C320KGT8
	3NO	30	C320KGT9
	2NO-1NC	21	C320KGT10
	1NO-2NC	12	C320KGT11
	3NC	03	C320KGT12
	4NO	40	C320KGT13
	3NO-1NC	31	C320KGT14
	2NO-2NC	22	C320KGT15
	1NO-3NC	13	C320KGT16
	4NC	04	C320KGT17
	3NO-1NCI	N/A	C320KGT18
	2NO-1NCI-1NC	N/A	C320KGT19
	2NO-1NO (EC)-1NC (LO)	N/A	C320KGT20
1NO-1NC-1NO (EC)-1NC (LO)	N/A	C320KGT21	

Notes

- ① NCI = Normally Closed early opening designed for use in reversing applications. EC = Early Closing. LO = Late Opening.
- ② For reference only—not part of catalog number.

33.1 NEMA Contactors and Starters

Freedom Series

NEMA Sizes 3–8—IEC Sizes L–Z

C320KGS42

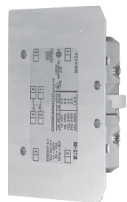

Base Auxiliary Contacts— NEMA Sizes 3–5, IEC Sizes L–S

Circuit	Contact Configuration Code ^①	NEMA Size 3 IEC Sizes L–N Catalog Number	NEMA Sizes 4–5 IEC Sizes P–S Catalog Number
NO	10	C320KGS31	C320KGS41
NO-NC	11	C320KGS32	C320KGS42

C320KGS22



Auxiliary Contacts—NEMA Sizes 3–5, IEC Sizes L–S

Circuit	Contact Configuration Code ^①	Catalog Number
NO	10	C320KGS20
NC	01	C320KGS21
NO-NC ^②	11	C320KGS22

Sealed Logic Level

Circuit	Contact Configuration Code ^①	Catalog Number
NO	10	C320KGS20L
NC	01	C320KGS21L
NO-NC ^③	11	C320KGS22L

Auxiliary Contacts—NEMA Sizes 6–8, IEC Sizes T–Z

Circuit	Contact Configuration Code ^①	Size	Catalog Number
NO-NC	11	NEMA 8, IEC Z	C320KA5
2NO-2NC	22	NEMA 6–7	C320KA6
2NO-2NC	22	IEC T–X	C320KA8

Auxiliary Contact Ratings (Amperes)

Ratings—NEMA A600

Current	AC Volts			
	120V	240V	480V	600V
Make and interrupting	60	30	15	12
Break	6	3	1.5	1
Continuous	10	10	10	10

Ratings—NEMA P300

Continuous Thermal Rating: 5A

DC Volts	Make/Break Amperes
125	1.10
250	0.55

Ratings—Logic Level

Minimum Ratings for Logic Level and Hostile Atmosphere Application

Minimum Amperes	20 mA
Minimum Volts	24 Vac/Vdc

Ratings C320KGS20L, C320KGS21L, C320KGS22L

DC-12		AC-12	
U_e	I_e	U_e	I_e
80	0.1	250	0.1

Notes

- ① For reference only—not part of catalog number.
- ② NO-NC occupies two position—L2 and L3, or R2 and R3. See figure on **Page 27**.
- ③ Form C contacts.

Auxiliary Contact Location

NEMA Sizes 00–2, IEC Sizes A–K

The sketches below illustrate the maximum number of auxiliary contacts that can be assembled to a contactor or starter and their locations.

assembled to a contactor or starter and their locations.

Auxiliary Contacts

Size	Poles	Available Mounting Positions ^{①②}		Catalog Number
		Open Type	Enclosed	
A–K	3	T1, L1	L1	AE16
00	3	T1, L1, R1	L1	AN16
0–2	3	T1, L1	L1	
A–K	3	L1, R1	L1, R1	AE56
00–2	3	T1, T2	—	AN56
A–C	2–4	T1, L1, R1	L1, R1	CE15
D–K	3	T1, L1	L1	
G–J	4	T1, R1	—	
G–J	5	T1	—	
00	2–4	T1, L1, R1	L1	CN15
0–2	2–3	T1, L1	L1	
1, 2	4	T1, L1	—	
1, 2	5	T1, L1	—	
10A	2–4	T1, L1, R1	L1	CN35
20–60A	2–3	T1, L1	L1	
60A	4	T1, L1	—	
60A	5	T1, L1	—	
A–K	3	L1, R1	L1, R1	CE55
00–2	3	T1, T2	—	CN55

Auxiliary Contact Location

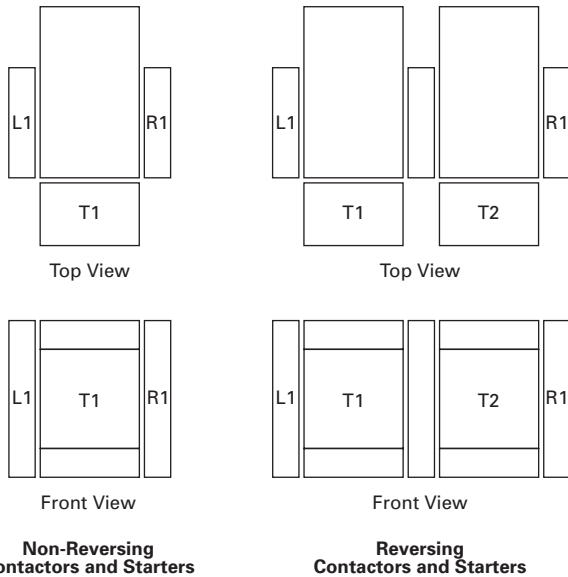

NEMA Sizes 3–8, IEC Sizes L–Z

The sketches below illustrate the maximum number of auxiliary contacts that can be assembled to a contactor and their locations.

Note: A base auxiliary contact must be added in position R1 before additional auxiliary contacts can be mounted on NEMA Size 3 and IEC Sizes L–N, or in L1 on NEMA Sizes 4–5 and IEC Sizes P–S.

Mounting Positions

Size	Available Mounting Positions ^①
NEMA Size 3, IEC Sizes L–N	R2, R3, L1, L2, L3
NEMA Sizes 4–5, IEC Sizes P–S	L2, L3, R1, R2, R3
NEMA Sizes 6–7, IEC Sizes T–X	R1
NEMA Size 8, IEC Size Z	L2, R2

Auxiliary Contact Location

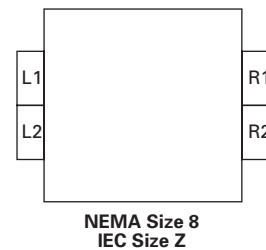
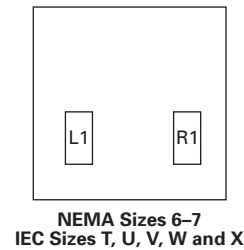
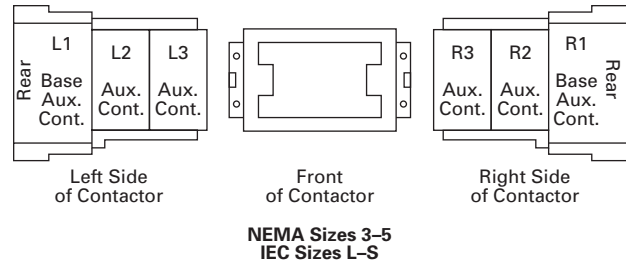

Notes

- ① Available positions on contactors or starters other than what is factory installed.
- ② When a pneumatic timer is mounted on contactor, only side mounted auxiliary contact positions are available. The solid-state timer, when added, takes up side mounted auxiliary contact position.

DC Magnet Coils

When Ordering Specify Conversion Kit for Field Assembly

- Catalog number

Factory Installed DC Coil

- For factory installed DC magnet coil on AC contactors or non-combination starters (open type only), substitute the code suffix from the table on this page for the magnet coil identifier in the device catalog number. EXAMPLE: For Size 0 AC contactor with a 24 Vdc coil, change AN16BN0AC to AN16BN0T1C

Application

- Connect for separate control
- Not for use with cover control switch operators
- Use twin break, heavy-duty pilot devices
- Designed for +10%, -20% rated voltage, continuous duty operation

Non-Reversing Kit Consists of:

- One encapsulated DC magnet coil
- One NCI or NO/NCI side mounted auxiliary contact

Note: These kits are supplied with a NO/NCI side mounted auxiliary contact in place of the NCI contact.

- Two blue colored connection wires
- One instruction publication

Operation

See next page for operation details.

DC Magnet Coils

Contactor or Starter Size	IEC	Volts	Conversion Data			NCI Interlock	Complete Conversion Kit		Factory Installed Code Suffix
			Magnet Coil	Amps P.U./Seal	Watts P.U./Seal		Catalog Number	Ship Wt. Lbs (kg)	
NEMA			Coil Number						
Non-Reversing—Kit Includes NCI Side Mounted Auxiliary Contact									
00 and 0 CN35-A, B, D D15 Relays	A-F	12	9-2988-11	6.4/0.28	76.8/3.36	C320KGD1	C335KD3R1	1.0 (0.5)	R1
		24	9-2988-12	3.2/0.14	76.8/3.36	C320KGD1	C335KD3T1		T1
		48	9-2988-13	1.6/0.07	76.8/3.36	C320KGD1	C335KD3W1		W1
		120	9-2988-14	0.64/0.028	76.8/3.36	C320KGD1	C335KD3A1		A1
① 00 and 0 CN35-A, B, D D15 Relays	A-F	12	9-2988-11	6.4/0.28	76.8/3.36	C320KGD2 ①	C335KD3R4	1.0 (0.5)	R4
		24	9-2988-12	3.2/0.14	76.8/3.36	C320KGD2 ①	C335KD3T4		T4
		48	9-2988-13	1.6/0.07	76.8/3.36	C320KGD2 ①	C335KD3W4		W4
		120	9-2988-14	0.64/0.028	76.8/3.36	C320KGD2 ①	C335KD3A4		A4
1 and 2 CN35-G	G-K	12	9-2990-1	15.4/0.42	185/4.98	C320KGD5	C335KD4R4	1.0 (0.5)	R4
		24	9-2990-2	7.7/0.21	185/4.96	C320KGD5	C335KD4T4		T4
		48	9-2990-3	3.9/0.11	185/5.04	C320KGD5	C335KD4W4		W4
		120	9-2990-4	1.5/0.041	185/4.87	C320KGD5	C335KD4A4		A4
3 CN35-K	L-N	12	9-3002-1	24/0.40	293/4.84	C320KGD3	C335KD5R1	2.0 (0.9)	R1
		24	9-3002-2	12/0.20	288/4.75	C320KGD3	C335KD5T1		T1
		48	9-3002-3	6.1/0.097	295/4.67	C320KGD3	C335KD5W1		W1
		120	9-3002-4	2.5/0.038	298/4.57	C320KGD3	C335KD5A1		A1
4 and 5 CN35-N, S	P-S	24	9-2026-4	18/0.22	400/5.3	C320KGD3	C335KA3T1	2.5 (1.1)	T1B
		48	9-2026-3	9/0.11	400/5.2	C320KGD3	C335KA3W1		W1B
		120	9-2026-2	3.3/0.05	450/5.4	C320KGD3	C335KA3A1		A1B
		240	9-2026-1	1.7/0.02	440/4.9	C320KGD3	C335KA3B1		B1B
Reversing									
00 and 0 CN35-A, B, D D15 relays	A-F	12	(2) 9-2988-1	6.4/0.28	76.8/3.36	(2) C320KGD1	C335RD3R1 ②	1.0 (0.5)	R1 ③
		24	(2) 9-2988-2	3.2/0.14	76.8/3.36	(2) C320KGD1	C335RD3T1 ②		T1 ③
		48	(2) 9-2988-3	1.6/0.07	76.8/3.36	(2) C320KGD1	C335RD3W1 ②		W1 ③
		120	(2) 9-2988-4	0.64/0.028	76.8/3.36	(2) C320KGD1	C335RD3A1 ②		A1 ③
1 and 2 CN35-G	G-K	12	(2) 9-2990-1	15.4/0.42	185/4.98	(2) C320KGD3 ④	—	—	R1 ③
		24	(2) 9-2990-2	7.7/0.21	185/4.96	(2) C320KGD3 ④	—		T1 ③
		48	(2) 9-2990-3	3.9/0.11	185/5.04	(2) C320KGD3 ④	—		W1 ③
		120	(2) 9-2990-4	1.5/0.041	185/4.87	(2) C320KGD3 ④	—		A1 ③

Notes

- ① These kits are supplied with a NO/NCI side mounted auxiliary contact in place of the NCI contact.
- ② Kit does not include mechanical interlock or crossover wiring. Two NO/NCI top mounted auxiliary contacts are supplied for electrical interlocking.
- ③ Factory installed DC coils on NEMA contactors and starters include a NO/NC top mounted auxiliary contact on each contactor for electrical interlocking. On IEC contactors and starters, a NC top mounted auxiliary contact is supplied on each contactor for electrical interlocking.
- ④ Available factory assembled only.

Operation

These DC coil kits have separate pick-up and seal windings. A **special** (side mounted) early-break NCI auxiliary contact is used to either disconnect the pick-up winding or insert the seal winding in series with the pick-up winding, depending on the frame size of the contactor. DC coil kits come in two styles, a suffix **1** and a suffix **4**. Suffix 1 contains only the **special** (side mounted) early break NCI auxiliary contact. Suffix 4 contains a NO contact in the same package as the **special** (side mounted) early-break NCI auxiliary contact.

Note: For NEMA Sizes 00 and 0 and IEC Sizes A–F, contactors

may utilize either suffix 1 or 4 DC coil kits; starters may utilize suffix 4 DC coil kits only. For NEMA Sizes 1 and 2 and IEC Sizes G–K, both contactors and starters may utilize a suffix 4 DC coil kit only.

On the above sizes only, when the **special** auxiliary package is mounted on the side of a contactor or starter, **no** standard auxiliary contact may be mounted on the same side.

Note: For NEMA Sizes 3–5 and IEC Sizes L–S, special coil NCI clearing contact is an add-on auxiliary (**must** mount on a base mount auxiliary contact; normally a 1NO). This arrangement will normally account for two of the three contact positions on the side of each contactor or starter.

Competitive Mounting Plates

The C321 adapter plates permit direct replacement of competitive starters with Freedom Series starters without drilling and tapping new mounting holes. Allen-Bradley 509, Eaton's A10

(adapter plate not required for replacing A10 Starter Sizes 1, 4 and 5), Furnas 14, ESP100, General Electric CR206, CR306, Siemens SXL, Square D 8536, Westinghouse A200, B200.

C321CMP1



Competitive Mounting Plates

Freedom NEMA Size	Index Number ^② Catalog Number
00, 0	C321CMP0
1	C321CMP1
2	C321CMP2
3	C321CMP3
4	C321CMP4
5	C321CMP5

Note

- ① 1NO available in Suffix 4 kits only.
- ② Handling number only—does not appear on product. The handling number is stamped on the carton label only.

Elementary Diagrams

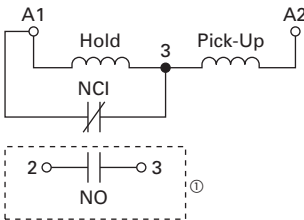

DC Coil Elementary Diagram for NEMA Sizes 1–3 and IEC Sizes G–N Contactors and Starters

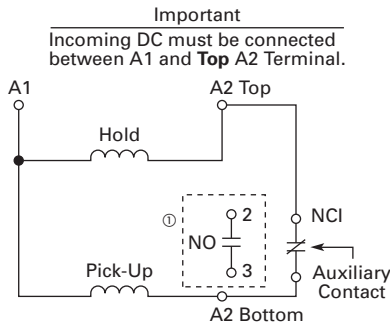

DC Coil Elementary Diagram for NEMA Sizes 00, 0, 4 and 5 and IEC Sizes A–F and P–S Contactors and Starters

Special Modifications

For Catalog Numbers AN16, AN56, CE15, CN15, CN35, CN55

Addition or Special Feature	Starter Size —NEMA									
	00	0	1/—	2	3	4	5	6	7	8
Control Circuit										
Extra auxiliary circuit, factory installed NO or NC—each contact ①	Consult sales office for pricing adders.									
Transient suppressor ①	Consult sales office for pricing adders.									
Power Circuit										
Contactor/starter for ring lug capability—add Mod Code T16 to catalog number (Power terminals only, control terminals as standard) Standalone overload relays can not accept ring lugs on line side	Consult sales office for pricing adders.									
Factory Installed Dust Covers										
Factory installed C320DSTCVR—add Mod Code -53 to catalog number ①						NA	NA	NA	NA	NA

Renewal Parts

For a complete listing of parts, refer to the Renewal Parts Publication Number referenced below.

For Catalog Numbers AN16, AN30, AN40, AN56, AN70, AN80, AN800, CN15, CN35 ② and CN55 Contactors and Starters (Size 00, 0)

Description	NEMA Size 00		NEMA Size 0	
	Series B1 Part No.	Series C1 Part No.	Series B1 Part No.	Series C1 Part No.
Renewal Parts Publication Number	22177	22177	22177	22177
Contact Kits				
Two-pole	③	③	③	③
Three-pole	③	③	③	③
Four-pole	③	③	③	③
Five-pole	③	③	③	③
Magnet Coils				
	Coil Suffix			
120V 60 Hz or 110V 50 Hz	A	9-2875-1	9-2875-1	9-2876-1
240V 60 Hz or 220V 50 Hz	B	9-2875-2	9-2875-2	9-2876-2
480V 60 Hz or 440V 50 Hz	C	9-2875-3	9-2875-3	9-2876-3
600V 60 Hz or 550V 50 Hz	D	9-2875-4	9-2875-4	9-2876-4
208V 60 Hz	E	9-2875-5	9-2875-5	9-2876-5
277V 60 Hz	H	9-2875-12	9-2875-12	9-2876-12
208/240V 60 Hz	J	9-2875-37	9-2875-37	9-2876-17
240V 50 Hz	K	9-2875-11	9-2875-11	9-2876-11
380–415V 50 Hz	L	9-2875-6	9-2875-6	9-2876-6
380V 50 Hz	L	—	—	—
415V 50 Hz	M	—	—	—
550V 50 Hz	N	—	—	—
24V 60 Hz–24V 50 Hz	T	9-2875-36	9-2875-36	9-2876-36
24V 60 Hz	T	—	—	—
24V 50 Hz	U	9-2875-36	9-2875-36	9-2876-36
32V 50 Hz	V	9-2875-16	9-2875-16	9-2876-16
48V 60 Hz	W	9-2875-8	9-2875-8	9-2876-8
48V 50 Hz	Y	9-2875-9	9-2875-9	9-2876-9
Magnet Frame Armature				
Lower magnet frame	③	③	③	③
Upper magnet frame	③	③	③	③

Notes

- ① These modifications are generally available in kit form at lower cost. See specific product sections for kit listings.
- ② CN35A = Size 00, CN35B and CN35D = Size 0, CN35G = Size 2, CN35K = Size 3, CN35N = Size 4, and CN35S = Size 5.
- ③ Replace with complete contactor.

For Catalog Numbers AN16, AN30, AN40, AN56, AN70, AN80, AN800, CN15, CN35 ① and CN55 Contactors and Starters (Size 1, 2)

Description	NEMA Size 1		NEMA Size 2		NEMA Size 3
	Series A1 Part No.	Series B1 Part No.	Series A1 Part No.	Series B1 Part No.	
Renewal Parts Publication Number	20861	22177	20861	22177	20426
Contact Kits					
Two-pole	6-65	6-65	6-65-7	6-65-7	6-43-5
Three-pole	6-65-2	6-65-2	6-65-8	6-65-8	6-43-6
Four-pole	6-65-9	6-65-9	6-65-15	6-65-15	—
Five-pole	6-65-10	6-65-10	6-65-16	6-65-16	—
Magnet Coils					
	Coil Suffix				
120V 60 Hz or 110V 50 Hz	A	9-3285-1	9-3285-1	9-3285-1	9-2756-1 KIT
240V 60 Hz or 220V 50 Hz	B	9-3285-2	9-3285-2	9-3285-2	9-2756-2 KIT
480V 60 Hz or 440V 50 Hz	C	9-3285-3	9-3285-3	9-3285-3	9-2756-3 KIT
600V 60 Hz or 550V 50 Hz	D	9-3285-4	9-3285-4	9-3285-4	9-2756-4 KIT
208V 60 Hz	E	9-3285-9	9-3285-9	9-3285-9	9-2756-5 KIT
277V 60 Hz	H	9-3285-7	9-3285-7	9-3285-7	9-2756-9 KIT
208/240V 60 Hz	J	—	—	—	—
240V 50 Hz	K	9-3285-14	9-3285-14	9-3285-14	9-2756-13 KIT
380–415V 50 Hz	L	9-3285-8	9-3285-8	9-3285-8	—
380V 50 Hz	L	—	—	—	9-2756-12 KIT
415V 50 Hz	M	—	—	—	9-2756-8 KIT
550V 50 Hz	N	—	—	—	9-2756-14 KIT
24V 60 Hz–24V 50 Hz	T	—	—	—	—
24V 60 Hz	T	9-3285-6	9-3285-6	9-3285-6	9-2756-6 KIT
24V 50 Hz	U	9-3285-12	9-3285-12	9-3285-12	9-2756-11 KIT
32V 50 Hz	V	9-3285-10	9-3285-10	9-3285-10	9-2756-10 KIT
48V 60 Hz	W	9-3285-11	9-3285-11	9-3285-11	9-2756-15 KIT
48V 50 Hz	Y	9-3285-13	9-3285-13	9-3285-13	9-2756-7 KIT
Magnet Frame Armature					
Lower magnet frame		17-18200	17-18200	17-18200	17-8955-2 KIT
Upper magnet frame		48-1936	48-1936	48-1936	48-1902 KIT

Note

① CN35A = Size 00, CN35B and CN35D = Size 0, CN35G = Size 2, CN35K = Size 3, CN35N = Size 4, and CN35S = Size 5.

33.1

NEMA Contactors and Starters

Freedom Series

For a complete listing of parts, refer to the Renewal Parts Publication Number referenced below.

For Catalog Numbers AN16, AN30, AN40, AN56, AN70, AN80, AN800, CN15, CN35 ^① and CN55 Contactors and Starters (Size 4, 5, 6)

Description	NEMA Size 4		NEMA Size 5		NEMA Size 6		
	Series A1 Part No.	Series B1 Part No.	Series A1 Part No.	Series B1 Part No.	Contactors and Starter Series A1, Starter Series B1 Part No.	Contactors and Starter Series B1, Starter Series C1 Part No.	
Renewal Parts Publication Number	20428	20428	20429	20429	20146	23349	
Contact Kits							
Two-pole	6-44	6-26	6-45	6-45	6-601-2	—	
Three-pole	6-44-2	6-26-2	6-45-2	6-45-2	6-601	6-648	
Magnet Coils							
	Coil Suffix						
120V 60 Hz or 110V 50 Hz	A	9-1891-1 KIT	9-1891-1 KIT	9-1891-1 KIT	9-1891-1 KIT	9-2698	9-3006
240V 60 Hz or 220V 50 Hz	B	9-1891-2 KIT	9-1891-2 KIT	9-1891-2 KIT	9-1891-2 KIT	9-2698-2	9-3006-2
480V 60 Hz or 440V 50 Hz	C	9-1891-3 KIT	9-1891-3 KIT	9-1891-3 KIT	9-1891-3 KIT	9-2698-3	9-3006-3
600V 60 Hz or 550V 50 Hz	D	9-1891-4 KIT	9-1891-4 KIT	9-1891-4 KIT	9-1891-4 KIT	9-2698-4	9-3006-4
208V 60 Hz	E	9-1891-13 KIT	9-1891-13 KIT	9-1891-13 KIT	9-1891-13 KIT	9-2698-5	—
277V 60 Hz	H	9-1891-26 KIT	9-1891-26 KIT	9-1891-26 KIT	9-1891-26 KIT	—	—
208/240V 60 Hz	J	—	—	—	—	—	—
240V 50 Hz	K	9-1891-20 KIT	9-1891-20 KIT	9-1891-20 KIT	9-1891-20 KIT	—	—
380–415V 50 Hz	L	—	—	—	—	9-2698-6	9-3006-7
380V 50 Hz	L	9-1891-14 KIT	9-1891-14 KIT	9-1891-14 KIT	9-1891-14 KIT	—	—
415V 50 Hz	M	9-1891-21 KIT	9-1891-21 KIT	9-1891-21 KIT	9-1891-21 KIT	—	—
550V 50 Hz	N	9-1891-8 KIT	9-1891-8 KIT	9-1891-8 KIT	9-1891-8 KIT	—	—
24V 60 Hz–24V 50 Hz	T	—	—	—	—	—	9-3006-8
24V 60 Hz	T	9-1891-15 KIT	9-1891-15 KIT	9-1891-15 KIT	9-1891-15 KIT	—	—
24V 50 Hz	U	9-1891-16 KIT	9-1891-16 KIT	9-1891-16 KIT	9-1891-16 KIT	—	—
48V 60 Hz	W	—	—	—	—	9-2698-8	9-3006-9
48V 50 Hz	Y	9-1891-18 KIT	9-1891-18 KIT	9-1891-18 KIT	9-1891-18 KIT	—	—
Overload Relays							
For replacement on existing starters three-pole— ambient compensated bimetallic		10-6530-4	10-6530-4	C306DN3B	C306DN3B	C306DN3B	C306DN3B
Current Transformer		—	—	42-3564	42-3564	42-3598	42-3598
Magnet Frame Armature ^②							
Lower Magnet Frame		48-1030-2	48-1030-2	48-1030-2	48-1030-2	—	—
Upper Magnet Frame		48-1029-4	48-1029-4	48-1029-4	48-1029-4	—	—

Feeder Group Renewal ^③

Volts	Hertz	NEMA Size 4		NEMA Size 5		NEMA Size 6	
		Series A1	Series B1	Series A1	Series B1	Contactors and Starter Series A1, Starter Series B1	Contactors and Starter Series B1, Starter Series C1
110–120	50/60	—	—	—	—	9-2705	9-3007
220–240	50/60	—	—	—	—	9-2705-2	9-3007-2
440–480	50/60	—	—	—	—	9-2705-3	9-3007-3
550–600	50/60	—	—	—	—	9-2705-4	9-3007-4
208	50/60	—	—	—	—	9-2705-5	9-3007-5
380–415	50/60	—	—	—	—	9-2705-6	9-3007-8
48–52	50/60	—	—	—	—	9-2705-8	9-3007-6

Notes

^① CN35A = Size 00, CN35B and CN35D = Size 0, CN35G = Size 2, CN35K = Size 3, CN35N = Size 4, and CN35S = Size 5.

^② Consult factory.

^③ Voltage ratings of the main coils must match those of the feeder group for proper operation of the starter/contactors.

For a complete listing of parts, refer to the Renewal Parts Publication Number referenced below.

For Catalog Numbers AN16, AN30, AN40, AN56, AN70, AN80, AN800, CN15, CN35^① and CN55 Contactors and Starters (Size 7, 8)

Description	NEMA Size 7		NEMA Size 8	
	Series A1 Part No.	Series B1 Part No.	Series A1 Part No.	Series B1 Part No.
Renewal Parts Publication Number	20848	20848	20849	20849
Contact Kits				
Two-pole	—	—	—	—
Three-pole	6-613	6-613	6-571	6-571
Magnet Coils		Coil Suffix		
120V 60 Hz or 110V 50 Hz	A	9-2698	9-2698	9-2654
240V 60 Hz or 220V 50 Hz	B	9-2698-2	9-2698-2	9-2654-2
480V 60 Hz or 440V 50 Hz	C	9-2698-3	9-2698-3	9-2654-3
600V 60 Hz or 550V 50 Hz	D	9-2698-4	9-2698-4	9-2654-4
208V 60 Hz	E	9-2698-5	9-2698-5	9-2654-6
277V 60 Hz	H	—	—	—
208/240V 60 Hz	J	—	—	—
240V 50 Hz	K	—	—	—
380–415V 50 Hz	L	—	—	—
380V 50 Hz	L	9-2698-6	9-2698-6	9-2654-5
415V 50 Hz	M	—	—	—
550V 50 Hz	N	—	—	—
24V 60 Hz–24V 50 Hz	T	—	—	—
24V 60 Hz	T	—	—	—
24V 50 Hz	U	—	—	—
32V 50 Hz	V	—	—	—
48V 60 Hz	W	—	—	—
48V 50 Hz	Y	—	—	—
Overload Relays				
For replacement on existing starters three-pole—ambient compensated bimetallic	C306DN3B	C306DN3B	C306DN3B	C306DN3B
Current Transformer	42-3598-2	42-3598-2	42-3598-3	42-3598-3
Magnet Frame Armature^②				
Lower magnet frame	—	—	—	—
Upper magnet frame	—	—	—	—

Notes

^① CN35A = Size 00, CN35B and CN35D = Size 0, CN35G = Size 2, CN35K = Size 3, CN35N = Size 4, and CN35S = Size 5.

^② Consult factory.

33.1

NEMA Contactors and Starters

Freedom Series

Feeder Group Renewal ^①

Volts	Hertz	NEMA Size 7		NEMA Size 8	
		Series A1	Series B1	Series A1	Series B1
110–120	50/60	9-2705	9-2705	—	—
220–240	50/60	9-2705-2	9-2705-2	—	—
440–480	50/60	9-2705-3	9-2705-3	—	—
550–600	50/60	9-2705-4	9-2705-4	—	—
208	50/60	9-2705-5	9-2705-5	—	—
380–415	50/60	9-2705-6	9-2705-6	—	—
48–52	50/60	9-2705-8	9-2705-8	—	—
120	50/60	—	—	9-2664	9-2664
240	50/60	—	—	9-2664-2	9-2664-2
480	50/60	—	—	9-2664-3	9-2664-3
600	50/60	—	—	9-2664-4	9-2664-4
380	50/60	—	—	9-2664-5	9-2664-5
208	50/60	—	—	9-2664-6	9-2664-6
415	50/60	—	—	9-2664-7	9-2664-7
110	50/60	—	—	9-2664-8	9-2664-8
220	50/60	—	—	9-2664-9	9-2664-9
550	50/60	—	—	9-2664-10	9-2664-10
440	50/60	—	—	9-2664-11	9-2664-11

Note

^① Voltage ratings of the main coils must match those of the feeder group for proper operation of the starter/contactors.

Technical Data and Specifications

All data is based on a standard contactor with no auxiliary devices and a 120 Vac or 24 Vdc magnet coil. Coil data has a $\pm 5\%$ range depending on the application, therefore specific data may vary.

Coil Data Notes

P.U.	Pick-up time is the average time taken from closing of the coil circuit to main contact touch
D.O.	Drop-out time is the average time taken from opening of the coil circuit to main contact separation
Cold	Coil data with a cold coil
Hot	Coil data with a hot coil

33.1

NEMA Contactors and Starters

Freedom Series

Specifications—Sizes 00–3

Description	Contactor Catalog Number/Size				
	CN15A NEMA Size 00	CN15B NEMA Size 0	CN15D NEMA Size 1	CN15G NEMA Size 2	CN15K NEMA Size 3
Configuration					
Number of poles	2, 3, 4	2, 3	2, 3, 4, 5	2, 3, 4, 5	2, 3
Auxiliary contacts, standard	4th pole NO (1)	Side NO (1)	Side NO (1)	Side NO (1)	Side NO (1)
Add-on auxiliary contacts	Top (4) or side (4)	Top (4) or side (3)	Top (4) or side (3)	Top (4) or side (3)	Left side (4) or right side (3)
Frame size	45 mm	45 mm	65 mm	65 mm	90 mm
Maximum voltage rating	600 Vac	600 Vac	600 Vac	600 Vac	600 Vac
Continuous ampere ratings (I)	9A	18A	27A	45A	90A
Maximum Horsepower (hp)					
Single-phase					
115V	1/3	1	2	3	7-1/2
230V	1	2	3	7-1/2	15
Three-phase					
200V	1-1/2	3	7-1/2	10	25
230V	1-1/2	3	7-1/2	15	30
460V	2	5	10	25	50
575V	2	5	10	25	50
AC Magnet Coil Data					
Pick-up volts—cold	74%	74%	74%	74%	72%
Pick-up volts—hot	78%	78%	78%	78%	76%
Pick-up voltamperes	80	100	230	230	390
Pick-up watts	49	65	95	95	112
Sealed voltamperes	7.5	10	28	28	49.8
Sealed watts	2.4	3.1	7.8	7.8	13
Drop-out volts—cold	75%	75%	75%	75%	75%
Drop-out volts—hot	75%	75%	75%	75%	75%
Maximum operation rate—ops/hour	12,000	12,000	12,000	12,000	7,200
Pick-up time (ms)	12	12	20	20	14
Drop-out time (ms)	12	12	14	14	11
Coil operating range % of rated voltage	-15% to +10%	-15% to +10%	-15% to +10%	-15% to +10%	-15% to +10%
DC magnet coil data	For DC magnet coils (and coil data), see Accessories, Pages 28 and 29.	For DC magnet coils (and coil data), see Accessories, Pages 28 and 29.	For DC magnet coils (and coil data), see Accessories, Pages 28 and 29.	For DC magnet coils (and coil data), see Accessories, Pages 28 and 29.	For DC magnet coils (and coil data), see Accessories, Pages 28 and 29.
Operating temperature	-20° to 65°C	-20° to 65°C	-20° to 65°C	-20° to 65°C	-20° to 65°C
Maximum operating altitude (ft)	6000	6000	6000	6000	6000
Mechanical life	20,000,000	20,000,000	10,000,000	10,000,000	6,000,000
Electrical Life (480V/60 Hz)					
AC-3	4,000,000	3,000,000	5,000,000	3,500,000	1,700,000
AC-4	90,000	85,000	200,000	62,000	80,000
Wire Range					
Power terminals	12–16 stranded, 12–14 solid Cu	8–16 stranded, 10–14 solid Cu	8–14 stranded or solid Cu	2–14 (upper) and/or 6–14 (lower) stranded or solid Cu	1/0–14 Cu
Control terminals	12–16 stranded, 12–14 solid Cu	12–16 stranded, 12–14 solid Cu	12–16 stranded, 12–14 solid Cu	12–16 stranded, 12–14 solid Cu	12–16 stranded, 12–14 solid Cu
Power terminal torque	7	15	20	40 (14–8 AWG)	35 (14–10 AWG)
Line and load—lb-in				45 (6–4 AWG)	40 (8 AWG)
				50 (3 AWG)	45 (6–4 AWG)
					50 (3–1/0 AWG)
Auxiliary contact rating	A600, P300	A600, P300	A600, P300	A600, P300	A600, P300

Specifications—Sizes 4–8

Description	Contactor Catalog Number/Size				
	CN15N NEMA Size 4	CN15S NEMA Size 5	CN15T NEMA Size 6	CN15U NEMA Size 7	CN15V NEMA Size 8
Configuration					
Number of poles	2, 3	2, 3	3	3	3
Auxiliary contacts, standard	Side NO (1)	Side NO (1)	Top left 2NO/2NC (1)	Top left 2NO/2NC (1)	Side 2NO/NC (1)
Add-on auxiliary contacts	Left side (3) or right side (4)	Left side (3) or right side (4)	Top right 2NO/2NC (1)	Top right 2NO/2NC (1)	NO/NC (2)
Frame size	180 mm	180 mm	280 mm	280 mm	334 mm
Maximum voltage rating	600 Vac	600 Vac	600 Vac	600 Vac	600 Vac
Continuous ampere ratings (I)	135A	270A	540A	810A	1215A
Maximum Horsepower (hp)					
Single-phase					
115V	—	—	—	—	—
230V	—	—	—	—	—
Three-phase					
200V	40	75	150	200	400
230V	50	100	200	300	450
460V	100	200	400	600	900
575V	100	200	400	600	900
AC Magnet Coil Data					
Pick-up volts—cold	72.5%	75%	75%	75%	75%
Pick-up volts—hot	76%	77%	75%	75%	75%
Pick-up voltamperes	1158	1158	1600	1600	2450
Pick-up watts	240	240	1345	1345	2060
Sealed voltamperes	100	100	25	25	75
Sealed watts	27.2	27.2	22	22	60
Drop-out volts—cold	75%	75%	①	①	①
Drop-out volts—hot	75%	75%	①	①	①
Maximum operation rate—ops/hour	2400	2400	N/A	N/A	N/A
Pick-up time (ms)	28	25	105	105	70
Drop-out time (ms)	14	13	200	200	50
Coil operating range % of rated voltage	–15% to +10%	–15% to +10%	–15% to +10%	–15% to +10%	–15% to +10%
DC magnet coil data	For DC magnet coils (and coil data), see Accessories, Pages 28 and 29.	For DC magnet coils (and coil data), see Accessories, Pages 28 and 29.	For DC magnet coils (and coil data), see Accessories, Pages 28 and 29.	For DC magnet coils (and coil data), see Accessories, Pages 28 and 29.	For DC magnet coils (and coil data), see Accessories, Pages 28 and 29.
Operating temperature	–20° to 65°C	–20° to 65°C	–20° to 65°C	–20° to 65°C	–20° to 65°C
Maximum operating altitude (ft)	6000	6000	6000	6,000	6000
Mechanical life	5,000,000	5,000,000	5,000,000	5,000,000	5,000,000
Electrical Life (480V/60 Hz)					
AC-3	800,000	500,000	590,000	450,000	420,000
AC-4	70,000	34,000	7400	5000	4200
Wire Range					
Power terminals	Open—3/0–8 Cu; Enclosed—250 kcmil– 6 Cu/Al	750 kcmil—2 or (2) 250 kcmil–3/0 Cu/Al	(2) 750 kcmil–3/0 Cu/Al	(3) 750 kcmil–3/0 Cu/Al	(4) 750 kcmil–1/0 Cu/Al
Control Terminals	12–16 stranded, 12–14 solid Cu	12–16 stranded, 12–14 solid Cu	12–16 stranded, 12–14 solid Cu	12–16 stranded, 12–14 solid Cu	12–16 stranded, 12–14 solid Cu
Power terminal torque line and load—lb-in	200	550	550	550	500
Auxiliary contact rating	A600, P300	A600, P300	A600, P300	A600, P300	A600, P300

Note

① 20–30% of rated coil voltage.

Electrical Life—AC-3 and AC-4 Utilization Categories

Life Load Curves

Eaton's Freedom Series NEMA contactors have been designed and manufactured for superior life performance in any worldwide application. All testing has been based on requirements as found in NEMA and UL standards and conducted by Eaton. Actual application life may vary depending on environmental conditions and application duty cycle.

Utilization Categories

The International Electrotechnical Commission (IEC) has developed utilization categories for contactors and auxiliary contacts. The IEC utilization categories are used to define the type of electrical load for estimating electrical life, and do not imply the devices are IEC rated.

AC-1—Non-inductive or slightly inductive loads, such as resistance furnaces and heating.

AC-2—Starting of slip-ring motors.

AC-3—Squirrel cage motors; starting, switching off motors during running.

AC-4—Squirrel cage motors; starting, plugging, inching or jogging.

Note: AC-3 tests are conducted at rated device currents and AC-4 tests are conducted at six times rated device currents. All tests have been run at 460V, 60 Hz.

Contactors Choice

- Decide what utilization category your application is and choose the appropriate curve
- Locate the intersection of the life-load curve of the appropriate contactor with the applications operational current (I_o), as found on the horizontal axis
- Read the estimated contact life along the vertical axis in number of operational cycles

AC-3 and AC-4 Utilization Categories

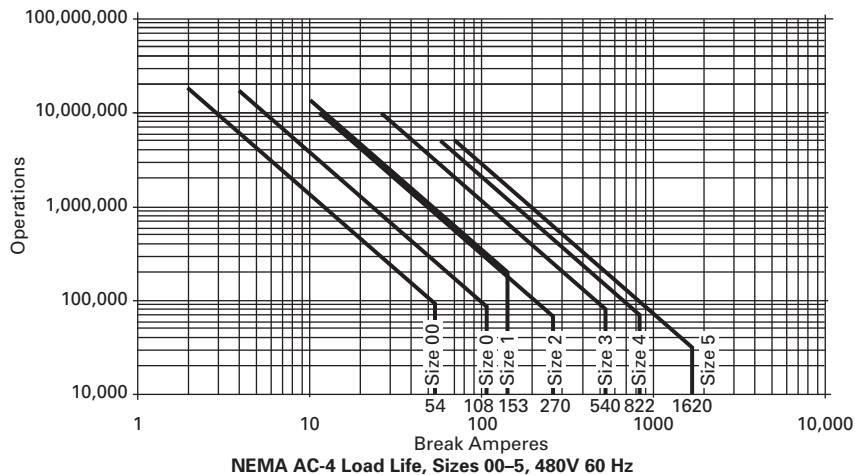
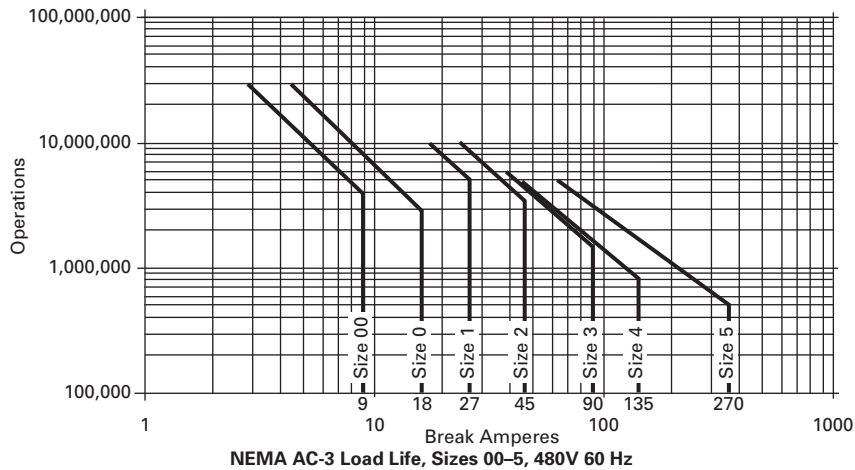

32A Overload—C306DN3B

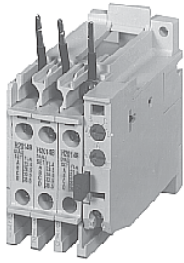

Contents

<i>Description</i>	<i>Page</i>
Contactors—Non-Reversing and Reversing	4
Starters—Three-Phase Non-Reversing and Reversing, Full Voltage	10
Starters—Single-Phase Non-Reversing, Full Voltage, Bi-Metallic Overload	15
Accessories	21
Renewal Parts	30
Technical Data and Specifications	35
Relays—Thermal Overload	
Product Selection	40
Accessories	44
Modifications	44
Replacement Parts	45
Technical Data and Specifications	46
Dimensions	48
C440/ XT Electronic Overload Relay	49

Relays—Thermal Overload

Product Description

C306 Overload Relays are designed for use with CE or CN non-reversing and reversing contactors. Four sizes are available for overload protection up to 144A.

Features

- Selectable manual or automatic reset operation
- Interchangeable heater packs adjustable $\pm 24\%$ to match motor FLA and calibrated for use with 1.0 and 1.15 service factor motors. Heater packs for 32A overload relay will mount in 75A overload relay—useful in derating applications such as jogging
- Class 10 or 20 heater packs
- Load lugs built into relay base
- Bimetallic, ambient compensated operated. Trip free mechanism
- Electrically isolated NO-NC contacts (pull RESET button to test). (Electrical ratings see table on **Page 47**)
- Overload trip indication
- Shrouded or fingerproof terminals to reduce possibility of electrical shock

Standards and Certifications

- Meets UL 508 single-phasing requirements
- UL listed, CSA certified, NEMA compliance and CE mark



33.1

NEMA Contactors and Starters

Freedom Series

Product Selection

C306 Thermal Overload Relays

33

C306DN3B



Contactors

NEMA Size	Maximum Ampere Rating	Number of Poles	Open Type Catalog Number	NEMA 1 Enclosed Catalog Number
00, 0	32 ②	3	C306DN3B	C306DG3B
1, 2	75 ②	3	C306GN3B	C306GG3B
3	105 ③	3	C306KN3	—
4	144 ③	3	C306NN3	—
5-8 ①	—	—	—	—

C306GN3B



C306DT3B

Standalone Applications

NEMA Size	Maximum Ampere Rating	Number of Poles	Open Type Catalog Number
00, 0, 1 ④	32	3	C306DT3B
1 ④	75	3	C306GT3B
3 ⑤	105	3	C306KN3
4 ⑤	144	3	C306NN3
5-8 ⑥	—	—	—

C306GT3B



- ① NEMA Sizes 5-8 use the 32A overload in conjunction with CTs.
- ② Series B overload relays have load lugs built into relay base and will only accept Series B heater packs. These relays can be directly attached to contactor or they can be DIN rail or panel mounted using adapter on **Page 45**.
- ③ These relays can be panel mounted only.
- ④ Overload relay assembled with mounting adapter for DIN rail or panel mount.
- ⑤ Panel mount only.
- ⑥ NEMA Sizes 5-8 use the 32A overload in conjunction with CTs.

Heater Pack Selection

Heater packs H2001B to H2017B and H2101B to H2117B are to be used only with Series B overload relays Catalog Numbers C306DN3B (Part No. 10-7016) and C306GN3B (Part No. 10-7020). The load lugs are built into the overload relay

base to allow load wiring prior to heater pack installation. The previous heater design had integral load lugs. The Series B heater packs are electrically equivalent to the previous heater design. Heaters H2018-3 to H2024-3 have not changed.

Starters with Series B Overload Relays ①

NEMA—AN Type Size	Series	IEC—AE Type Size	Series
00–0	C	A–F	C
1–2	B	G–K	B
5	B	G–K	B
6	C	G–K	B
7–8	B	G–K	B

**Heater Pack
H2001B–H2017B**



Standard Trip—Class 20 Heater

Overload Relay Size	Motor Full Load Ampere Rating Dial Position				Catalog Number ②
	A	B	C	D	
For Use with NEMA Sizes 00–0 Series C, NEMA Sizes 1–2 Series B; IEC Sizes A–F Series C, IEC Sizes G–K Series B					
32A or 75A	0.254	0.306	0.359	0.411	H2001B-3
	0.375	0.452	0.530	0.607	H2002B-3
	0.560	0.676	0.791	0.907	H2003B-3
	0.814	0.983	1.15	1.32	H2004B-3
	1.20	1.45	1.71	1.96	H2005B-3
	1.79	2.16	2.53	2.90	H2006B-3
	2.15	2.60	3.04	3.49	H2007B-3
	3.23	3.90	4.56	5.23	H2008B-3
	4.55	5.50	6.45	7.40	H2009B-3
	6.75	8.17	9.58	11.0	H2010B-3
	9.14	10.8	12.4	14.0	H2011B-3
	14.0	16.9	19.9	22.8	H2012B-3
	18.7	22.7	26.7	30.7	H2013B-3
	23.5	28.5	33.5	38.5	H2014B-3
For Use with NEMA Size 2, IEC Sizes G–K Only, Series B					
75A	29.0	34.0	39.1	44.1	H2015B-3
	39.6	45.5	51.5	57.4	H2016B-3
	53.9	60.9	67.9	74.9	H2017B-3

Notes

- ① The series of a starter is the last digit of the listed catalog number. Example: AN16DN0AB.
- ② Heater packs are shipped three to a carton. catalog numbers are for three heater packs.

Heater Pack
H2018–H2024



Standard Trip—Class 20 Heater, continued

Overload Relay Size	Motor Full Load Ampere Rating Dial Position				Catalog Number ^①
	A	B	C	D	
For Use with NEMA Sizes 3–4, IEC Sizes L–N Only—Series A					
105A or 144A	8.0	9.2	10.3	11.5	H2025-3
	11.4	12.8	14.3	15.7	H2026-3
	14.3	15.7	17.4	19.0	H2027-3
	18.0	20.2	22.3	24.5	H2018-3
	24.6	27.6	30.5	33.4	H2019-3
	33.5	37.5	41.5	45.6	H2020-3
	45.7	51.2	56.7	62.1	H2021-3
	62.2	69.7	77.1	84.6	H2022-3
	84.7	95.0	105.0	115.0	H2023-3
106.0	118.0	131.0	144.0	H2024-3	
For Use with Size 5 Starters—Series B and IEC P, R and S with 300/5 CT					
32A ^②	49	59	69	79	H2004B-3
	72	87	103	118	H2005B-3
	107	130	152	174	H2006B-3
	129	156	182	209	H2007B-3
	194	234	274	—	H2008B-3
For Use with Size 6 Starters Only—Series B and IEC T–V with 600/5 CT					
32A ^②	144	174	205	235	H2005B-3
	215	259	304	348	H2006B-3
	258	312	365	419	H2007B-3
	388	468	547	627	H2008B-3
For Use with Size 7 Starters Only—Series B and IEC W–X with 1000/5 CT					
32A ^②	163	197	230	264	H2004B-3
	240	290	342	392	H2005B-3
	358	432	506	580	H2006B-3
	430	520	608	698	H2007B-3
	646	780	912	—	H2008B-3
For Use Size 8 Starters Only—Series B and IEC Z with 1500/5 CT					
32A ^②	244	295	345	396	H2004B-3
	360	435	513	588	H2005B-3
	537	648	759	870	H2006B-3
	645	780	912	1047	H2007B-3
	969	1170	1368	—	H2008B-3

Notes

- ① Heater packs are shipped three to a carton. catalog numbers are for three heater packs.
- ② Sizes 5–8 and IEC P–Z use the 32A overload relay with current transformers.

Heater Pack
H2101B–H2117B



Fast Trip—Class 10 Heater

Overload Relay Size	Motor Full Load Ampere Rating Dial Position				Catalog Number ^①
	A	B	C	D	
For Use with NEMA Sizes 00–0 Series C, NEMA Sizes 1–2 Series B; IEC Sizes A–F Series C, IEC Sizes G–K Series B					
32A or 75A	0.260	0.313	0.367	0.420	H2101B-3
	0.384	0.464	0.543	0.623	H2102B-3
	0.570	0.688	0.806	0.924	H2103B-3
	0.846	1.02	1.20	1.37	H2104B-3
	1.28	1.55	1.83	2.10	H2105B-3
	1.92	2.33	2.74	3.15	H2106B-3
	2.30	2.79	3.28	3.77	H2107B-3
	3.38	4.10	4.82	5.54	H2108B-3
	4.96	6.03	7.09	8.16	H2109B-3
	7.07	8.58	10.1	11.6	H2110B-3
	9.60	11.2	12.8	14.4	H2111B-3
	14.4	17.5	20.7	23.8	H2112B-3
	18.7	21.8	25.0	28.1	H2113B-3
23.5	27.3	31.0	34.8	H2114B-3	
For Use with Size 2, IEC Sizes G–K Only—Series B					
75A	28.3	32.6	37.0	41.3	H2115B-3
	36.6	42.3	48.1	53.8	H2116B-3
	53.8	60.8	67.9	74.9	H2117B-3
For Use with Size 5 Starters Only—Series B and IEC P, R and S with 300/5 CT					
32A ^②	51	61	72	82	H2104B-3
	77	93	110	126	H2105B-3
	115	140	164	189	H2106B-3
	138	167	197	226	H2107B-3
	203	246	289	—	H2108B-3
For Use with Size 6 Starters Only—Series B and IEC T–V with 600/5 CT					
32A ^②	154	186	220	252	H2105B-3
	230	280	329	378	H2106B-3
	276	335	394	452	H2107B-3
	406	492	578	—	H2108B-3
For Use with Size 7 Starters Only—Series B and IEC W–X with 1000/5 CT					
32A ^②	169	204	240	274	H2104B-3
	256	310	366	420	H2105B-3
	384	466	543	630	H2106B-3
	460	558	656	754	H2107B-3
	676	820	—	—	H2108B-3
For Use with Size 8 Starters Only—Series B and IEC Z with 1500/5 CT					
32A ^②	254	306	360	411	H2104B-3
	384	465	549	630	H2105B-3
	576	699	822	945	H2106B-3
	690	837	984	1131	H2107B-3
	1014	1230	—	—	H2108B-3

Notes

- ① Heater packs are shipped three to a carton. catalog numbers are for three heater packs.
- ② Sizes 5–8 and IEC P–Z use the 32A overload relay with current transformers.

33.1

NEMA Contactors and Starters

Freedom Series

33

Accessories

DIN Rail and Panel Mounting Adapter

These adapters are required when component overload relays are to be separately mounted. The terminal base

adapter includes line terminals and connects with the overload relays on **Page 40**.

C306TB1

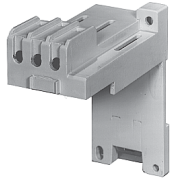

DIN Rail and Panel Mounting Adapter

Description	Catalog Number
For 32A overload relay	C306TB1
For 75A overload relay	C306TB2B ①

Locking Cover for Overload Relay—C306 Only

Snap-on transparent or opaque plastic panel for covering access port to the overload relay trip setting

dial—helps prevent accidental or unauthorized changes to trip and reset setting.

Overload Relay Cover



Locking Cover for Overload Relay—C306 Only

Description	Min. Order Qty. (Std. Pkg.)	Catalog Number
Clear cover, no accessibility	50	C320PC3
Gray cover, no accessibility with auto only nib	50	C320PC4
Gray cover, no accessibility with manual only nib	50	C320PC5
Gray cover with FLA dial accessibility, A, B, C, D positions and auto only nib	50	C320PC6
Gray cover with FLA dial accessibility, A, B, C, D positions and manual only nib	50	C320PC7

Notes

① This Series B adapter will accept Series A or B overload relays (C306GN3 or C306GN3B), C306TB2 can only be used with C306GN3.

Modifications

C306 Thermal Overload Relays with Mounting Adapter

Consists of a thermal overload relay mounted to a terminal base adapter—

permits fast and easy installation.

C306 Thermal Overload Relays with Mounting Adapter

Description	Catalog Number
C306DN3B + C306TB1	C306DT3B
C306GN3B + C306TB2B	C306GT3B

Replacement Parts

Heater Pack Replacement

The heater pack series is determined by the 6th character of the catalog number. Series A or prior heater packs (identified by either "A" or "-" as the 6th character) have built-in load lugs. Series B or later heater

packs do not (load lugs are on overload relay). Replacement of Series A or earlier heater packs with Series B or later heater packs, requires the one time addition of Lug Adapter Kit C3606KAL1-3B to the Series A1 overload relay.

Superseded Series A Heater Pack



Series B Heater Pack



Heater Pack Replacement Requirements

Existing Heater Pack Catalog Numbers	Replacement Product Required
H2001-3–H2013-3 H2001A-3–H2013A-3	Lug adapter kit C306KAL1-3B and Series B heater pack
H2001B-3–H2013B-3	Series B heater pack
H2014-3 H2014A-3	When inventory is exhausted, replace with lug adapter kit C3606KAL1-3B and Series B heater pack
H2014B-3	Series B heater pack
H2015-3–H2017-3	When inventory is exhausted, replace with heater pack chosen from table below
H2015A-3–H2017A-3	When inventory is exhausted, replace with lug adapter kit C3606KAL1-3B and Series B heater pack
H2015B-3–H2017B-3	Series B heater pack

Heater Pack Ratings

Motor Full Load Ampere Rating

Dial Position	A	B	C	D	Order Heater Pack Catalog Number
	29.0	32.5	36.0	39.5	H2015B-3
	39.6	44.3	49.1	53.8	H2016B-3
	53.9	60.4	66.8	74.9	H2017B-3

Overload Relay Lug Adapter Kit

Superseded 32A Series A Overload Relay—C306DN3

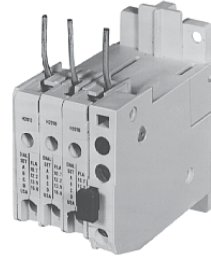

These kits are used in conjunction with Catalog Numbers H2001B–H2014B or H2101B–H2114B heater packs as a means of utilizing these Series B heater packs in Catalog Numbers C306DN3 and C306GN3 Series A1 overload relays. The kit consists of three lug

Superseded 75A Series A Overload Relay—C306GN3

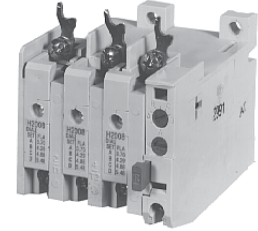

adapters and installation instructions. When installing Series B heater packs plus lug adapters in Series A overload relays, refer to heater pack FLA adjustment tables originally supplied with equipment (also supplied with kit).

C306KAL1



Overload Relay Lug

Description	Catalog Number
Series A1 overload relay lug adapter kit	C306KAL1-3B

Overload Relay Replacement—Series A Only

When replacing a Catalog Number C306DN3 (Part No. 10-6044) or C306GN3 (10-6319) Series A overload relay on a starter, order a Series B overload relay and Series B heater packs.

Technical Data and Specifications

Operation

C306 Overload Relay Setting

For motors having a 1.15 service factor, rotate the FLA (Full Load Amperes) adjustment dial to correspond to the motor's FLA rating.

Estimate the dial position when the motor FLA falls between two letter values as shown in the example.

For motors having a 1.0 service factor, rotate the FLA dial one-half position counterclockwise (CCW).

FLA Dial Adjustment

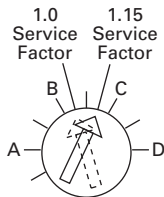

Example of 12.0 FLA setting for heater pack number H2011B showing position for 1.0 or 1.15 service factor motors.

The overload relay is factory set at M for manual reset operation. For automatic reset operation, turn the reset adjustment dial to the A position as shown in the illustration.

Automatic reset is not intended for two-wire control devices.

Manual/Automatic Reset

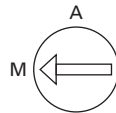

Example of setting for manual reset.

Test for Trip Indication

To test overload relay for trip indication when in manual reset, pull out the blue reset button. An orange flag will appear indicating that the device has tripped. Push reset button in to reset.

Warning—To provide continued protection against fire or shock hazard, the complete overload relay must

be replaced if burnout of the heater element occurs.

General

“Overload relays are provided to protect motors, motor control apparatus and motor-branch circuit conductors against excessive heating due to motor overloads and failure to start. This definition does not include: 1) motor circuits over 600V, 2) short circuits, 3) ground faults and 4) fire pump control.” (NEC Art. 430-31)

Time Current Characteristics

The time-current characteristics of an overload relay is an expression of performance which defines its operating time at various multiples of its current setting. Tests are run at Underwriters Laboratories (UL) in accordance with NEMA Standards and the NEC. UL requires:

- When tested at 100 percent of its current rating, the overload relay shall trip ultimately

- When tested at 200 percent of its current rating, the overload relay shall trip in not more than 8 minutes
- When tested at 600 percent of the current rating, the overload relay shall trip in not more than 10 or 20 seconds, depending on the Class of the relay

“Current Rating” is defined as the minimum current at which the relay will trip. Per NEC, an overload must ultimately trip at 125% of FLA current (heater) setting for a 1.15 service factor motor and 115% FLA for a 1.0 service factor motor.

“Current Setting” is defined as the FLA of the motor and thus the overload heater pack setting.

Example: 600% of current rating is defined as 750% (600 x 1.25) of FLA current (heater) setting for a 1.15 service factor motor. A 10A heater setting must trip in 20 seconds or less at 75A motor current for a Class 20 relay.

Class 10 and Class 20 Trip Curves

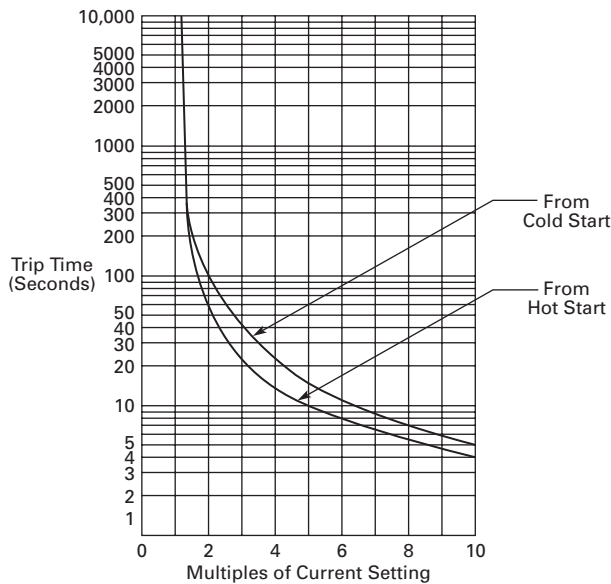

Class 10 Overload Relay 25°C Open Rating

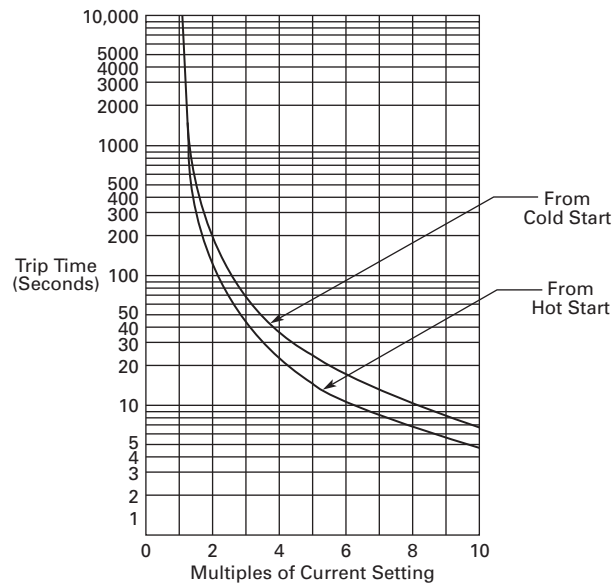

Class 20 Overload Relay 25°C Open Rating

Wire (75°C) Sizes—AWG or kcmil—NEMA Sizes 00–2, IEC A–K—Open

Power Terminals—Line

IEC Size	NEMA Size	Cu Only
A, B, C	00	12–16 stranded, 12–14 solid
D, E, F	0	8–16 stranded, 10–14 solid
	1	8–14 stranded or solid
G, H, J, K	2	3–14 (upper) and/or 6–14 (lower) stranded or solid ①

Power Terminals—Load—Cu Only (Stranded or Solid)

Catalog Number	Terminal	Wire Size
C306DN3B	32A	14–6 AWG
C306GN3B	75A	14–2 AWG

Control Terminals—Cu Only

12–16 AWG stranded, 12–14 AWG solid

Wire (75°C) Sizes—AWG or kcmil—NEMA Sizes 3–8, IEC L–N—Open

Power Terminals—Line and Load

IEC Size	NEMA Size	Wire Size
L	3	1/0–14 Cu/Al
M	—	1/0–8 Cu/Al
N	—	3/0–8 Cu/Al
—	4	Open—3/0–8 Cu Enclosed—250 kcmil—6 Cu/Al
—	5	750 kcmil—2 or (2) 250 kcmil—3/0 Cu/Al
	6–7	(2) 750 kcmil—3/0 Cu/Al
	8	(2) 750 kcmil—1/0 Cu/Al

Control Terminals—Cu Only

12–16 AWG stranded, 12–14 AWG solid

Power Terminal Torque Line and Load Terminals

Catalog Number	Terminal	Torque in lb-in
C306DT3B	32A	20
C306GT3B	75A	35 (14–10 AWG) 40 (8 AWG) 45 (6–4 AWG) 50 (3–2 AWG)
C306KN3 (socket head screw)	105A	120 (3/16) 200 (1/4) 250 (5/16)
C306NN3 (socket head screw)	144A	120 (3/16) 200 (1/4) 250 (5/16)
C306NN3 (slotted head screw)		35 (14–10 AWG) 40 (8 AWG) 45 (6–4 AWG) 50 (3–1/0 AWG)

Plugging and Jogging Service Horsepower Ratings ②

NEMA Size	200V	230V	460V	575V
00	—	1/2	1/2	1/2
0	1-1/2	1-1/2	2	2
1	3	3	5	5
2	7-1/2	10	15	15
3	15	20	30	30
4	25	30	60	60
5	60	75	150	150
6	125	150	300	300

Overload Relay UL/CSA Contact Ratings Control Circuit ③

AC Volts	120V	240V	480V	600V
NC Contact B600				
Make and break amperes	30	15	7.5	6
Break amperes	3	1.5	0.75	0.6
Continuous amperes	5	5	5	5
NO Contact C600				
Make and break amperes	15	7.5	3.375	3
Break amperes	1.5	0.75	0.375	0.3
Continuous amperes	2.5	2.5	2.5	2.5

Notes

- ① Two compartment box lug.
- ② Maximum horsepower where operation is interrupted more than 5 times per minute or more than 10 times in a 10 minute period. NEMA standard ICS 2-1993 table 2-4-3.
- ③ DC ratings cover Freedom Series coils only.

33.1 NEMA Contactors and Starters

Freedom Series

Dimensions

Approximate Dimensions in Inches (mm)

Stand-Alone Overload Relays

32A and 75A Sizes—C306DT38 and C306GT3B

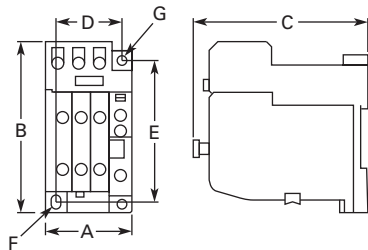

105A and 144A Sizes—C306KN38 and C306NN3B

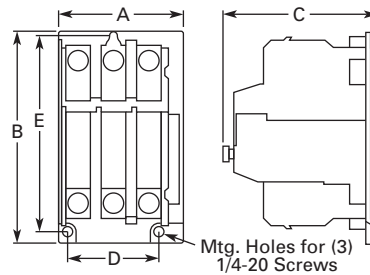

Dimensions and Shipping Weights

Ampere Size	Wide A	High B	Deep C	Mounting D	E	F (Slot)	G (Hole)	Shipping Weight Lbs (kg)
32A	1.77 (45.0)	4.13 (104.9)	3.69 (93.7)	1.36 (34.5)	3.74 (95.0)	0.18 x 0.30 (4.6 x 7.6)	0.18 (4.6) dia.	0.8 (0.4)
75A	2.54 (64.5)	4.69 (119.1)	3.74 (95.0)	2.00 (50.8)	3.45 (87.6)	0.22 x 0.26 (5.6 x 6.6)	0.21 (5.3) dia.	1.4 (0.6)
105 and 144A	4.00 (101.6)	7.17 (182.1)	4.91 (124.7)	3.00 (76.2)	6.62 (168.1)	—	—	4.0 (1.8)

C440/XT Electronic Overload Relay



Contents

<i>Description</i>	<i>Page</i>
Contactors—Non-Reversing and Reversing	4
Starters—Three-Phase Non-Reversing and Reversing, Full Voltage	10
Starters—Single-Phase Non-Reversing, Full Voltage, Bi-Metallic Overload	15
Accessories	21
Renewal Parts	30
Technical Data and Specifications	35
Relays—Thermal Overload	
C440/XT Electronic Overload Relay	
Standards and Certifications	50
Catalog Number Selection	51
Product Selection	52
Accessories	53
Technical Data and Specifications	56
Dimensions	62

C440/XT Electronic Overload Relay

Product Description

Eaton’s new electronic overload relay (EOL) is the most compact, high-featured, economical product in its class. Designed on a global platform, the new EOL covers the entire power control spectrum including NEMA, IEC and DP contactors. The NEMA and DP versions are offered with the *C440* designation while the IEC offering has the *XT* designation. The electronic design provides reliable, accurate and value driven protection and communications capabilities in a single compact device. It is the flexible choice for any application requiring easy-to-use, reliable protection.

Eaton has a long history of innovations and product development in motor control and protection, including both traditional NEMA, as well as IEC control. It was from this experience that the C440 was developed, delivering new solutions to meet today’s demands.

C440 is a self-powered electronic overload relay available up to 100A as a self contained unit. With external CTs, C440 can protect motor up to 1500 FLA. Available add-on accessories include remote reset capability and communication modules with I/O for DeviceNet, PROFIBUS, and Modbus.

Features and Benefits

Features

- Reliable, accurate, electronic motor protection
- Easy to select, install and maintain
- Compact size
- Flexible, intelligent design
- Global product offering—available with NEMA, IEC and DP power control

Size/Range

- Broad FLA range (0.33–1500A)
- Selectable trip class (10A, 10, 20, 30)
- Direct mounting to NEMA, IEC and DP contactors
- Most compact electronic overload in its class

Motor Control

- Two B600 alarm (NO) and fault (NC) contacts
- Test/Trip button

Motor Protection

- Thermal overload
- Phase loss
- Selectable (ON/OFF) phase unbalance
- Selectable (ON/OFF) ground fault

User Interface

- Large FLA selection dial
- Trip status indicator
- Operating mode LED
- DIP switch selectable trip class, phase unbalance and ground fault
- Selectable Auto/Manual reset

Feature Options

- Remote reset
 - 120 Vac
 - 24 Vac
 - 24 Vdc
- Tamper-proof cover
- Communications modules
 - Modbus RTU RS-485
 - DeviceNet with I/O
 - PROFIBUS with I/O
 - Modbus RTU with I/O (Q4 2010)
 - Ethernet IP (planned)

33.1

NEMA Contactors and Starters

Freedom Series

33

Benefits

Reliability and Improved Uptime

- C440 provides the users with peace of mind knowing that their assets are protected with the highest level of motor protection and communication capability in its class
- Extends the life of plant assets with selectable motor protection features such as trip class, phase unbalance and ground fault
- Protects against unnecessary downtime by discovering changes in your system (line/load) with remote monitoring capabilities
- Status LED provides added assurance that valuable assets are protected by indicating the overload operational status

Flexibility

- Available with NEMA, IEC and DP contactors
- Improves return on investment by reducing inventory carrying costs with wide FLA adjustment (5:1) and selectable trip class
- Patented design incorporates built-in ground fault protection thus eliminating the need for separate CTs and modules
- Flexible communication with optional I/O enables easy integration into plant management systems for remote monitoring and control
- Available as an open component and in enclosed control and motor control center assemblies

Monitoring Capabilities

- Individual phase currents RMS
- Average three-phase current RMS
- Thermal memory
- Fault indication (overload, phase loss, phase unbalance, ground fault)

Safety

- IP 20 rated terminal blocks
- Available in Eaton's industry leading FlashGard MCCs
- Tested to the highest industry standards such as UL, CSA, CE and IEC
- RoHS compliant

Standards and Certifications

- UL
- CSA
- CE
- NEMA
- IEC/EN 60947 VDE 0660
- ISO 13849-1 (EN954-1)
- RoHS
- ATEX directive 94/9/EC
- Equipment Group 2, Category 2



Electronic Overload Education

Description	Definition	Cause	Effect if not Protected	C440/XT Protection
Motor Protection				
Thermal overload	Overload is a condition in which current draw exceeds 115% of the full load amperage rating for an inductive motor.	<ul style="list-style-type: none"> • An increase in the load or torque that is being driven by the motor. • A low voltage supply to the motor causes the current to go high to maintain the power needed. • A poor power factor causing above normal current draw. 	<ul style="list-style-type: none"> • Increase in current draw leads to heat and insulation breakdown, which can cause system failure. • Increase in current can increase power consumption and waste valuable energy. 	<ul style="list-style-type: none"> • Thermal trip behavior is defined by UL, CSA and IEC standards. • Trip class is settable from 10A, 10, 20, 30
Ground fault	A line to ground fault.	A current leakage path to ground.	An undetected ground fault can burn through multiple insulation windings, ultimately leading to motor failure, not to mention risk to equipment or personnel	Fixed protective setting that takes the starter offline if ground fault current exceeds 50% of the FLA dial setting, i.e., if the FLA dial is set to 12A, the overload relay will trip if the ground current exceeds 6A.
Unbalanced phases (voltage and current)	Uneven voltage or current between phases in a three-phase system.	When a three-phase load is powered with a poor quality line, the voltage per phase may be unbalanced.	Unbalanced voltage causes large unbalanced currents and as a result this can lead to motor stator windings being overloaded, causing excessive heating, reduced motor efficiency and reduced insulation life.	Fixed protective setting that takes the starter offline if a phase drops below 50% of the other two phases.
Phase loss—current (single-phasing)	One of the three-phase voltages is not present.	Multiple causes, loose wire, improper wiring, grounded phase, open fuse, etc.	Single-phasing can lead to unwanted motor vibrations in addition to the results of unbalanced phases as listed above.	Fixed protective setting that takes the starter offline if a phase drops below 50% of the other two phases.

Catalog Number Selection

Freedom Series NEMA Starters with C440 Electronic Overload Relays ①

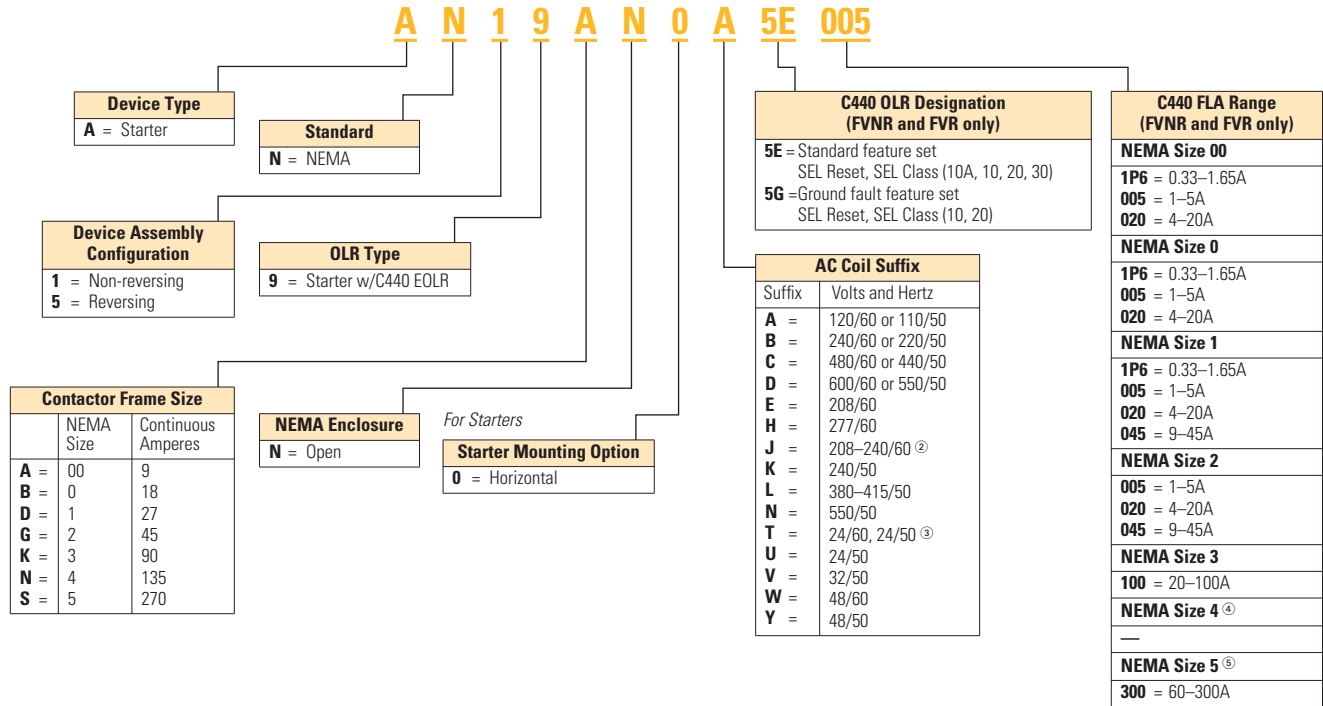

Notes

- ① See Page 52 for Product Selection.
- ② NEMA Sizes 00 and 0 only.
- ③ NEMA Sizes 00 and 0 only. Sizes 1–3 are 24/60 only.
- ④ Starter not shipped as an assembled unit. Order NEMA Size 4 contactor (CN15NN3A) plus current transformers (ZEB-XCT300) and 1–5A C440 overload relay (C440A1A005SELAX or C440A2A005SELAX).
- ⑤ NEMA Size 5 starter available with 60–300A panel mounted CTs. Starter shipped as an assembled unit with 1–5A C440 overload relay (C440A1A005SELAX or C440A2A005SELAX).

33.1

NEMA Contactors and Starters

Freedom Series

Product Selection

Type AN19/59 Freedom Series Starters

Type AN19/59 Freedom Series Starters with C440 Electronic Overload Relays

33

NEMA Starter



Non-Reversing and Reversing

NEMA Size	Continuous Ampere Rating	Service Limit Current Rating (Amps)	Maximum UL Horsepower						Three-Pole Non-Reversing ^{①②} Catalog Number	Three-Pole Reversing ^{①②} Catalog Number
			Single-Phase		Three-Phase		480V	600V		
			115V	230V	208V	240V				
00	9	11	1/3	1	1-1/2	1-1/2	2	2	AN19AN0_5E_	AN59AN0_5E_
0	18	21	1	2	3	3	5	5	AN19BN0_5E_	AN59BN0_5E_
1	27	32	2	3	7-1/2	7-1/2	10	10	AN19DN0_5E_	AN59DN0_5E_
2	45	52	3	7-1/2	10	15	25	25	AN19GN0_5E_	AN59GN0_5E_
3	90	104	—	—	25	30	50	50	AN19KN0_5E_	AN59KN0_5E_
4 ^③	135	156	—	—	40	50	100	100	③	③
5 ^④	270	311	—	—	75	100	200	200	AN19SN0_5E_	AN59SN0_5E_

Type AN19/59 Freedom Series Starters with C440 with Ground Fault Electronic Overload Relays

NEMA Starter with Ground Fault



Non-Reversing and Reversing

NEMA Size	Continuous Ampere Rating	Service Limit Current Rating (Amps)	Maximum UL Horsepower						Three-Pole Non-Reversing ^{①②} Catalog Number	Three-Pole Reversing ^{①②} Catalog Number
			Single-Phase		Three-Phase		480V	600V		
			115V	230V	208V	240V				
00	9	11	1/3	1	1-1/2	1-1/2	2	2	AN19AN0_5G_	AN59AN0_5G_
0	18	21	1	2	3	3	5	5	AN19BN0_5G_	AN59BN0_5G_
1	27	32	2	3	7-1/2	7-1/2	10	10	AN19DN0_5G_	AN59DN0_5G_
2	45	52	3	7-1/2	10	15	25	25	AN19GN0_5G_	AN59GN0_5G_
3	90	104	—	—	25	30	50	50	AN19KN0_5G_	AN59KN0_5G_
4 ^③	135	156	—	—	40	50	100	100	③	③
5 ^④	270	311	—	—	75	100	200	200	AN19SN0_5G_	AN59SN0_5G_

Coil Suffix Codes

Suffix	Coil Volts and Hertz	Suffix	Coil Volts and Hertz
A	120/60 or 110/50	L	380–415/50
B	240/60 or 220/50	N	550/50
C	480/60 or 440/50	T	24/60, 24/50
D	600/60 or 550/50	U	24/50
E	208/60	V	32/50
H	277/60	W	48/60
J	208–240/60	Y	48/50
K	240/50		

C440 FLA Range (FVNR and FVR Starters Only)

NEMA Size	OLR Code	FLA Range	OLR Code	FLA Rating
00	1P6	0.33–1.65A	020	4.0–20A
	005	1.0–5.0A	—	—
0	1P6	0.33–1.65A	020	4.0–20A
	005	1.0–5.0A	—	—
1	1P6	0.33–1.65A	020	4.0–20A
	005	1.0–5.0A	045	9.0–45A
2	005	1.0–5.0A	045	9.0–45A
	020	4.0–20A	—	—
3	100	20–100A	—	—
4 ^③	300	—	—	60–300A
5 ^③	300	60–300A	—	—



Notes

- ① Underscore (_) indicates coils suffix required, see Coil Suffix table above.
- ② Underscore (_) indicates OLR designation required, see C440 FLA Range table above.
- ③ Starter not shipped as an assembled unit. Order NEMA Size 4 contactor (CN15NN3A) plus current transformers (ZEB-XCT300) and 1–5A C440 overload relay (C440A1A005SELAX or C440A2A005SELAX).
- ④ NEMA Size 5 starter available with 60–300A panel mounted CTs. Starter shipped as an assembled unit with 1–5A C440 overload relay (C440A1A005SELAX or C440A2A005SELAX).

Accessories

CT Kits

Accessories

	Description	Catalog Number
Safety Cover 	Safety Cover Clear Lexan cover that mounts on top of the FLA dial and DIP switches when closed.	ZEB-XSC
Reset Bar 	Reset Bar Assembles to the top of the overload to provide a larger target area for door mounted reset operators.	ZEB-XRB
Remote Reset 	Remote Reset Remote reset module (24 Vdc) ① Remote reset module (120 Vac) ① Remote reset module (24 Vac) ①	C440-XCOM ZEB-XRR-120 ZEB-XRR-24

Communication

The C440 is provided with two levels of communication capability.

Basic Communication via Expansion Module—Monitoring Only

Basic communication on the C440 is accomplished using an expansion module. The expansion module plugs into the expansion bay on the C440 overload relay, enabling communications with the overload via their Modbus RTU (RS-485) network. No additional parts are required. See figure below.



Basic Communication—Modbus

Advanced Communication—Monitoring and Control

C440 also has the ability to communicate on industrial protocols such as DeviceNet, PROFIBUS, Modbus RTU and Modbus TCP, and Ethernet (planned) while providing control capability using I/O.

An expansion module (mentioned earlier) combined with a communication adapter and a communication module allows easy integration onto the customer’s network. See figure below.



Advanced Communication—Communication Adapter with Communication Module

Advanced Communication—Communication Module

The communication adapter comes standard with four inputs and two outputs (24 Vdc or 120 Vac) while providing the customer with flexible mounting options (DIN rail or panel). See figure below,

Note

① Customer can wire remote mounted button to reset module (i.e., 22 mm pushbutton, catalog number M22-D-B-GB14-K10).

33.1 NEMA Contactors and Starters



Freedom Series

33

The following information can be viewed using the communication option:

- Motor status—running, stopped, tripped or resetting
- Individual rms phase currents (A, B, C)
- Average of three-phase rms current
- Percent thermal capacity
- Fault codes (only available prior to reset)
- Percent phase unbalance
- Ground fault current and percent
- Overload relay settings—trip class, DIP switch selections, reset selections
- Modbus address (can be set over the network)

Communication Accessories

	Description	Catalog Number
Expansion Module 	Expansion module (Remote Reset/Modbus RTU, RS-485 Communication)	C440-XCOM
Communication Adapter 	Communication adapter kit (DIN C Panel mounted adapter, required for advance communication option)	C440-COM-ADP
	DeviceNet communication module kit—120V I/O (consists of C440-XCOM + C441K + C440-COM-ADP)	C440-DN-120
	DeviceNet communication module kit—24 Vdc I/O (consists of C440-XCOM + C441L + C440-COM-ADP)	C440-DN-24
	PROFIBUS communication module kit—120V I/O (consists of C440-XCOM + C441S + C440-COM-ADP)	C440-DP-120
	PROFIBUS communication module kit—24V I/O (consists of C440-XCOM + C441Q + C440-COM-ADP)	C440-DP-24
	Modbus communication module kit—120V I/O (consists of C440-XCOM + C441N + C440-COM-ADP)	C440-MOD-120
	Modbus communication module kit—24 Vdc I/O (consists of C440-XCOM + C441P + C440-COM-ADP)	C440-MOD-24
	Ethernet IP communication module kit—120V I/O (consists of C440-XCOM + C441R + C440-COM-ADP)	C440-EIP-120

Modbus Communication Module

The Modbus module combined with an expansion module and a communication adapter provide Modbus communication capability to the C440 electronic overload relay.



**Modbus
Communication Module**

Features and Benefits

- The Modbus communication module is capable of baud rates up to 115K
- The Modbus address and baud rate configuration can be easily changed using the HMI user interface
- Modbus address and baud rate are set via convenient DIP switches; LEDs are provided to display Modbus traffic
- Configuration with common Modbus configuration tools
- Terminals
 - Unique locking mechanism provides for easy removal of the terminal block with the field wiring installed
 - Each terminal is marked for ease of wiring and troubleshooting
- Selectable I/O assemblies
 - 4IN/2OUT
 - Signal types include 24 Vdc I/O and 120 Vac I/O
- Each I/O module is optically isolated between the field I/O and the network adapter to protect the I/O and communication circuits from possible damage due to transients and ground loops
- Input Module features a user-definable input debounce, which limits the effects of transients and electrical noise
- Output Module supports a user-definable safe state for loss of communication; hold last state, ON or OFF

DeviceNet Communication Modules

The DeviceNet Communication Module provides monitoring and control for the C440 overload relay from a single DeviceNet node. These modules also offer convenient I/O in two voltage options, 24 Vdc and 120 Vac.



**DeviceNet
Communication Module**

Features and Benefits

- Communication to DeviceNet uses only one DeviceNet MAC ID
- Configuration
 - DeviceNet MAC ID and Baud rate are set via convenient DIP switches with an option to set from the network
 - Advanced configuration available using common DeviceNet tools
- Terminals
 - Unique locking mechanism provides for easy removal of the terminal block with the field wiring installed
 - Each terminal is marked for ease of wiring and troubleshooting
- Selectable I/O assemblies
 - 4IN/2OUT
 - Signal types include 24 Vdc I/O and 120 Vac I/O
- Each I/O module is optically isolated between the field I/O and the network adapter to protect the I/O and communication circuits from possible damage due to transients and ground loops
- Input Module features a user-definable input debounce, which limits the effects of transients and electrical noise
- Output Module supports a user-definable safe state for loss of communication; hold last state, ON or OFF
- Combined status LED

PROFIBUS Communication Modules

The PROFIBUS module combined with an expansion module and a communication adapter provide Modbus communication capability to the C440 electronic overload relay.



**PROFIBUS
Communication Module**

Features and Benefits

- The PROFIBUS communication module is capable of baud rates up to 12 Mb
- PROFIBUS address is set via convenient DIP switches; LEDs are provided to display PROFIBUS status
- Intuitive configuration with common PROFIBUS configuration tools
- Terminals
 - Unique locking mechanism provides for easy removal of the terminal block with the field wiring installed
 - Each terminal is marked for ease of wiring and troubleshooting
- Selectable I/O assemblies
 - 4IN/2OUT
 - Signal types include 24 Vdc I/O and 120 Vac I/O
- Each I/O module is optically isolated between the field I/O and the network adapter to protect the I/O and communication circuits from possible damage due to transients and ground loops
- Input Module features a user-definable input debounce, which limits the effects of transients and electrical noise
- Output Module supports a user-definable safe state for loss of communication; hold last state, ON or OFF

Technical Data and Specifications

Electronic Overload Relays up to 1500A

Description	Specification	
	45 mm	55 mm
Electrical Ratings	Range	Range
Operating voltage (three-phase) and frequency	690 Vac (60/50 Hz)	690 Vac (60/50 Hz)
FLA Range	0.33–1.65A 1–5A 4–20A 9–45A	20–100A
Use with Contactors		
XTEC frames	B, C, D	F, G
Freedom NEMA sizes	00, 0, 1, 2	3
Trip Class	10A, 10, 20, 30 Selectable	10A, 10, 20, 30 Selectable
Motor Protection		
Thermal overload setting	1.05 x FLA: does not trip 1.15 x FLA: overload trip	1.05 x FLA: does not trip 1.15 x FLA: overload trip
Feature	Range	Range
Phase loss	Fixed threshold 50%	Fixed threshold 50%
Phase unbalance (selectable: enable/disable)	Fixed threshold 50%	Fixed threshold 50%
Ground fault (selectable: enable/disable)	50% of FLA dial setting >150% = 2 sec >250% = 1 sec	50% of FLA dial setting >150% = 2 sec >250% = 1 sec
Reset	Manual/automatic	Manual/automatic
Indicators		
Trip status	Orange flag	Orange flag
Mode LED	One flash: Overload operating properly Two flashes: Current is above FLA dial setting—pending trip	One flash: Overload operating properly Two flashes: Current is above FLA dial setting—pending trip
Options		
Remote reset	Yes	Yes
Reset bar	Yes	Yes
Communication expansion module	Yes	Yes
Communication adapter	Yes	Yes
Capacity		
Load terminals		
Terminal capacity	12–10 AWG (4–6 mm ²) 8–6 AWG (6–16 mm ²)	6–1 AWG (16–50 mm ²)
Tightening torque	20–25 lb-in (2.3–2.8 Nm) 25–30 lb-in (2.8–3.4 Nm)	25–30 lb-in (2.8–3.4 Nm)
Input, auxiliary contact and remote reset terminals		
Terminal capacity	2 x (18–12) AWG	2 x (18–12) AWG
Tightening torque	5.3 lb-in (0.8–1.2 Nm)	5.3 lb-in (0.8–1.2 Nm)
Voltages		
Insulation voltage U _i (three-phase)	690 Vac	690 Vac
Insulation voltage U _i (control)	500 Vac	500 Vac
Rated impulse withstand voltage	6000 Vac	6000 Vac
Overtoltage category/pollution degree	III/3	III/3

Electronic Overload Relays up to 1500A, continued

Description	Specification	
	45 mm	55 mm
Auxiliary and Control Circuit Ratings		
Conventional thermal continuous current	5A	5A
Rated operational current—IEC AC-15		
Make contact (1800 VA)		
120V	15A	15A
240V	15A	15A
415V	0.5A	0.5A
500V	0.5A	0.5A
Break contact (180 VA)		
120V	1.5A	1.5A
240V	1.5A	1.5A
415V	0.9A	0.9A
500V	0.8A	0.8A
IEC DC-13 (L/R F 15 ms1)		
0–250V	1.0A	1.0A
Rated operational current—UL B600		
Make contact (3600 VA)		
120V	30A	30A
240V	15A	15A
480V	7.5A	7.5A
600V	6A	6A
Break contact (360 VA)		
120V	3A	3A
240V	1.5A	1.5A
480V	0.75A	0.75A
600V	0.6A	0.6A
R300—Vdc ratings (28 VA)		
0–120V	0.22A	0.22A
250V	0.11A	0.11A
Short-Circuit Rating without Welding		
Maximum fuse	6A gG/gL	6A gG/gL
Environmental Ratings		
Ambient temperature (operating)	–13°F to 149°F (–25°C to 65°C)	–13°F to 149°F (–25°C to 65°C)
Ambient temperature (storage)	–40°F to 185°F (–40°C to 85°C)	–40°F to 185°F (–40°C to 85°C)
Operating humidity UL 991 (H3)	5% to 95% non-condensing	5% to 95% non-condensing
Altitude (no derating) NEMA ICS1	2000m	2000m
Shock (IEC 60068-2-27)	15g any direction	15g any direction
Vibration (IEC 60068-2-6)	3g any direction	3g any direction
Pollution degree per IEC 60947-4-1	3 for product (2 for pcb)	3 for product (2 for pcb)
Ingress protection	IP20	IP20
Protection against direct contact when actuated from front (IEC 536)	Finger- and back-of-hand proof	Finger- and back-of-hand proof
Mounting position	Any	Any
Climatic proofing	Damp heat, constant to IEC 60068-2-30	Damp heat, constant to IEC 60068-2-30

Electronic Overload Relays up to 1500A, continued

Description	Specification	
	45 mm	55 mm
Electrical/EMC		
Radiated emissions IEC 60947-4-1-Table 15 EN 55011 (CISPR 11) Group 1, Class A, ISM	30 mHz to 1000 mHz	30 mHz to 1000 mHz
Conducted emissions IEC 60947-4-1-Table 14 EN 55011 (CISPR 11) Group 1; Class ISM	0.15 mHz to 30 mHz	0.15 mHz to 30 mHz
ESD immunity IEC 60947-4-1 (Table 13)	±8 kV air, ±6 kV contact	±8 kV air, ±6 kV contact
Radiated immunity IEC 60947-4-1 IEC 61000-4-3	10 V/m 80 mHz–1000 mHz 3 V/m from 1.4 to 2.7 GHz 80% amplitude modulated 1 kHz sine wave	10 V/m 80 mHz–1000 mHz 3 V/m from 1.4 to 2.7 GHz 80% amplitude modulated 1 kHz sine wave
Conducted immunity IEC 60947-4-1, IEC 61000-4-6	140 dub (10V rms) 150 kHz–100 mHz	140 dub (10V rms) 150 kHz–100 mHz
Fast transient immunity IEC 60947-4-1 (Table 13) IEC 61000-4-4	±4 kV using direct method with accessory installed in expansion bay ±2 kV using direct method	±4 kV using direct method with accessory installed in expansion bay ±2 kV using direct method
Surge immunity IEC 60947-4-1 (Table 13) IEC 61000-4-5 a Class 4	Three-phase power inputs: ±4 kV line-to-line (DM) ±4 kV line-to-ground (CM) With accessory installed in expansion bay: ±2 kV line-to-line (DM) →1.2/50 us; 2 kV line-to-earth, 1 kV line-to-line ±4 kV line-to-ground (CM)	Three-phase power inputs: ±4 kV line-to-line (DM) ±4 kV line-to-ground (CM) With accessory installed in expansion bay: ±2 kV line-to-line (DM) →1.2/50 us; 2 kV line-to-earth, 1 kV line-to-line ±4 kV line-to-ground (CM)
Power freq. magnetic field immunity IEC 60947-4-1, IEC 61000-4-8	30 A/m, 50 Hz	30 A/m, 50 Hz
Electromagnetic field IEC 60947-4-1 Table 13, IEC 61000-4-3	10 V/m	10 V/m
Distortion IEEE 519	5% THD max., 5th harmonic 3% max.	5% THD max., 5th harmonic 3% max.
Electrostatic discharge (ESD) IEC 61000-4-2, EN 61131-2	4 kV contact 8 kV air discharge	4 kV contact 8 kV air discharge
Electrical fast transient (EFT) IEC 61000-4-4, EN 61131-2	±2 kV using direct method	±2 kV using direct method
Surge immunity IEC 61000-4-5, EN 61131-2	±2 kV line-to-ground (CM)	±2 kV line-to-ground (CM)

Communication Modules

Description	Modbus	DeviceNet	PROFIBUS
Electrical/EMC			
Radiated emissions IEC 60947-4-1—Table 15, EN 55011 (CISPR 11) Group 1, Class A	30–1000 mHz	30–1000 mHz	30–1000 mHz
Conducted emissions IEC 60947-4-1—Table 14, EN 55011 (CISPR 11) Group 1, Class A	0.15–30 mHz	0.15–30 mHz	0.15–30 mHz
ESD immunity IEC 60947-4-1 (Table 13)	±8 kV air, ±4 kV contact	±8 kV air, ±4 kV contact	±8 kV air, ±4 kV contact
Radiated immunity IEC 60947-4-1	10 V/m 80–1000 mHz 80% amplitude modulated 1 kHz sine wave	10 V/m 80–1000 mHz 80% amplitude modulated 1 kHz sine wave	10 V/m 80–1000 mHz 80% amplitude modulated 1 kHz sine wave
Conducted immunity IEC 60947-4-1	140 dBuV (10V rms) 150 kHz–80 mHz	140 dBuV (10V rms) 150 kHz–80 mHz	140 dBuV (10V rms) 150 kHz–80 mHz
Fast transient immunity IEC 60947-4-1 (Table 13) IEC 6100-4-4	±2 kV using direct method	±2 kV supply and control, ±1 kV communication	±2 kV supply and control, ±1 kV communication
Surge immunity IEC 60947-4-1 (Table 13) IEC 61000-4-5 Class 3	User I/O and communication lines ^① : ±1 kV line-to-line (DM) ±2 kV line-to-ground (CM)	User I/O and communication lines: ±0.5 kV line-to-line (DM) ±1 kV line-to-ground (CM)	User I/O and communication lines: ±0.5 kV line-to-line (DM) ±1 kV line-to-ground (CM)
Electromagnetic field ^① IEC 60947-4-1 (Table 13) IEC 61000-4-3	10 V/m	10 V/m	10 V/m
Environmental Ratings			
Ambient temperature (operating)	–4°F to 122°F (–20°C to 50°C)	–13°F to 122°F (–25°C to 50°C)	–13°F to 122°F (–25°C to 50°C)
Ambient temperature (storage)	–40°F to 185°F (–40°C to 85°C)	–40°F to 185°F (–40°C to 85°C)	–40°F to 185°F (–40°C to 85°C)
Operating humidity	5–95% noncondensing	5–95% noncondensing	5–95% noncondensing
Altitude (no derating)	2000m	2000m	2000m
Shock (IEC 60068-2-27)	15G any direction	15G any direction	15G any direction
Vibration (IEC 60068-2-6)	3G any direction	3G any direction	3G any direction
Pollution degree per IEC 60947-1	3	3	3
Degree of protection	IP20	IP20	IP20
Overvoltage category per UL 508	III	III	III
DeviceNet			
DeviceNet connections	—	Group 2, polling, bit strobe, explicit, no UCMM	—
DeviceNet baud rate	—	125K, 250K, 500K	—
PROFIBUS			
PROFIBUS connections	—	—	Group 2, polling, bit strobe, explicit, no UCMM
PROFIBUS baud rate	—	—	9.6K, 19.2K, 45.45K, 93.75K, 187.5K, 500K, 1.5M, 3M, 6M, 12M
C441_ 24 Vdc Input			
Nominal input voltage	24 Vdc	24 Vdc	24 Vdc
Operating voltage	18–30 Vdc	18–30 Vdc	18–30 Vdc
Number of inputs	4	4	4
Signal delay	5 ms (programmable to 65 sec)	5 ms (programmable to 65 sec)	5 ms (programmable to 65 sec)
OFF-state voltage	<6 Vdc	<6 Vdc	<6 Vdc
ON-state voltage	>18 Vdc	>18 Vdc	>10 Vdc
Nominal input current	5 mA	5 mA	5 mA
Isolation	1500V	1500V	1500V
Terminal screw torque	7–9 in-lb	7–9 in-lb	7–9 in-lb
24V source current	50 mA	50 mA	50 mA

Note

^① Relates to C441M only.

Communication Modules, continued

Description	Modbus	DeviceNet	PROFIBUS
Operating Voltage Range—DC Input Modules			
OFF state	0–6 Vdc	0–6 Vdc	0–6 Vdc
Transition region	6–18 Vdc	6–18 Vdc	6–18 Vdc
ON state	18–30 Vdc	18–30 Vdc	18–30 Vdc
C441_ 120 Vac Input			
Nominal input voltage	120 Vac	120 Vac	120 Vac
Operating voltage	80–140 Vac	80–140 Vac	80–140 Vac
Number of inputs	4	4	4
OFF-state voltage	<30 Vac	<30 Vac	<20 Vac
ON-state voltage	>80 Vac	>80 Vac	>70 Vac
Nominal input current	15 mA	15 mA	15 mA
Signal delay	1/2 cycle	1/2 cycle	1/2 cycle
Isolation	1500V	1500V	1500V
Terminal screw torque	7–9 in-lb	7–9 in-lb	7–9 in-lb
Operating Voltage Range—AC Input Modules			
OFF state	0–30 Vac	0–30 Vac	0–30 Vac
Transition region	30–80 Vac	30–80 Vac	30–80 Vac
ON state	80–140 Vac	80–140 Vac	80–140 Vac
Output Modules			
Nominal voltage	120 Vac 24 Vdc	120 Vac 24 Vdc	120 Vac 24 Vdc
Number of outputs	(2) 1NO Form A 1NO/NC Form C	(2) 1NO Form A 1NO/NC Form C	(2) 1NO Form A 1NO/NC Form C
Relay OFF time	3 ms	3 ms	3 ms
Relay ON time	7 ms	7 ms	7 ms
Max. current per point ^①	5A (B300 rated)	5A (B300 rated)	5A (B300 rated)
Electrical life	100,000 cycles	100,000 cycles	100,000 cycles
Mechanical life	1,000,000 cycles	1,000,000 cycles	1,000,000 cycles

Note

^① Resistive current at 55°C ambient.

Short Circuit Ratings (North America CSA, cUL)

Changes to UL 508A and NEC in recent years have brought a focus to control panel safety with regard to short-circuit current ratings (SCCR). Eaton’s C440 electronic overload relays combined with **XT** series IEC and Freedom Series NEMA contactors provide a wide variety of SCCR solutions needed for a variety of applications. The SCCR data in this document reflects the latest information as of April 2010.

C440/XT Standalone Overload Relays (XT, C440)

Overload FLA Range	Maximum Operating Voltage	Standard-Fault Short Circuit Data			High-Fault Short Circuit Data Fuses (RK5, J, CC)			Thermal-Magnetic Circuit Breakers		
		600V (kA)	Maximum Fuse Size (A) (RK5)	Maximum Breaker Size (A)	480V (kA)	600V (kA)	Maximum Fuse Size	480V (kA)	600V (kA)	Maximum Breaker Size
0.33–1.65A	600 Vac	1	6	15	—	—	—	—	—	—
1–5A	600 Vac	5	20	20	100	100	30	100	35	20
4–20A	600 Vac	5	80	80	100	100	100	100	35	80
9–45A	600 Vac	5	175	175	100	100	100	100	35	100/175 (480/600)
20–100A	600 Vac	10	400	400	100	100	200	150	35	250/400 (480/600)

NEMA Freedom Series Starters with C440 Electronic Overload Relays

NEMA Size	Maximum Operating Voltage	High-Fault Short Circuit Data Fuses (RK5, J, CC)		Maximum Fuse Size	Thermal-Magnetic Circuit Breakers		
		480V	600V		480V	600V	Maximum Breaker Size
00	0.33–1.65A	100	100	30	—	—	—
	1–5A	100	100	30	100	35	35
	4–20A	100	100	30	100	35	35
0	0.33–1.65A	100	100	60	—	—	—
	1–5A	100	100	60	100	35	70
	4–20A	100	100	60	100	35	70
1	0.33–1.65A	100	100	100	—	—	—
	1–5A	100	100	100	100	35	100
	4–20A	100	100	100	100	35	100
	9–45A	100	100	100	100	35	100
2	1–5A	100	100	100	100	35	175
	4–20A	100	100	100	100	35	175
	9–45A	100	100	100	100	35	175
3	20–100A	100	100	200	50	50	250

IEC XT Starters with XT Electronic Overload Relays

Contactor Frame Size	Maximum Operating Voltage	High-Fault Short Circuit Data Fuses (RK5, J, CC)		Maximum Fuse Size	Thermal-Magnetic Circuit Breakers		
		480V	600V		480V	600V	Maximum Breaker Size
B	1–5A	100	100	30	—	—	—
	4–20A	100	100	30	—	—	—
C	1–5A	100	100	60	—	—	—
	4–20A	100	100	60	—	—	—
	9–45A	100	100	60	—	—	—
D	9–45A	100	100	200	65	35	175
	20–100A	100	100	200	65	35	175
F	20–100A	100	100	200	65	65	350
G	20–100A	100	100	200	65	65	350

33.1

NEMA Contactors and Starters

Freedom Series

Dimensions

Approximate Dimensions in Inches (mm)

NEMA Starters

33

Full Voltage Non-Reversing Starters

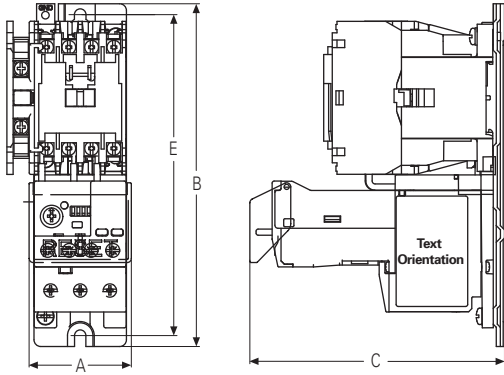

Sizes 00, 0

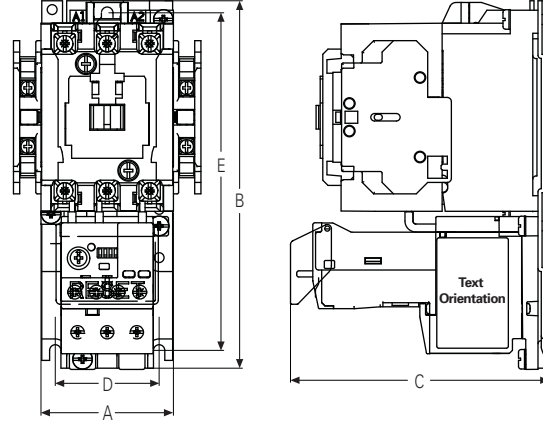

Sizes 1, 2

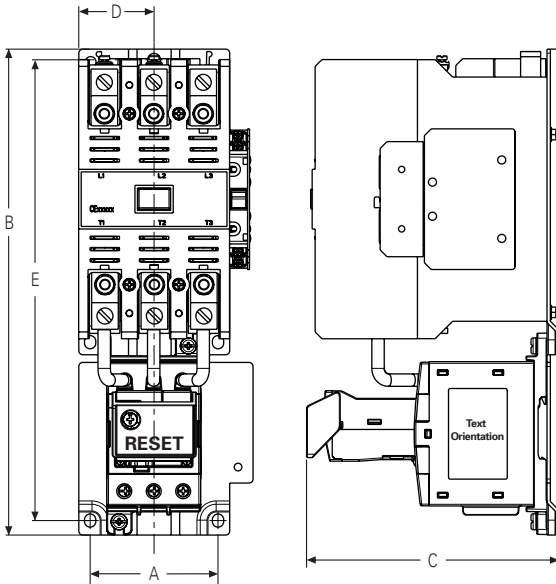

Size 3

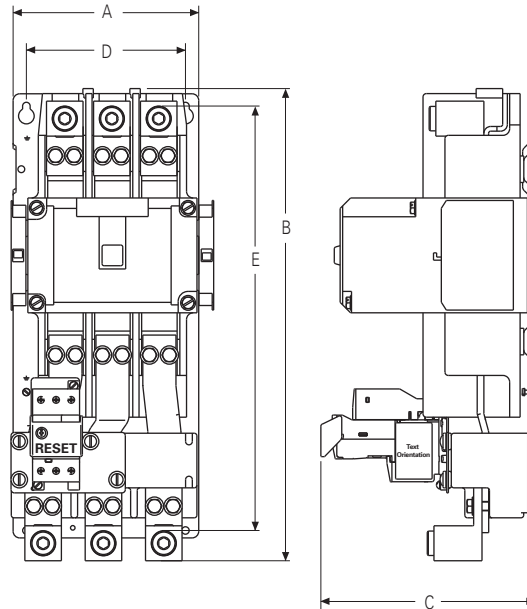

Size 5

NEMA Size	A	B	C	D	E
00, 0	1.97 (50.0)	6.60 (167.6)	4.90 (124.5)	—	6.18 (157.0)
1, 2	2.60 (65.0)	7.10 (180.0)	4.98 (126.5)	2.00 (50.8)	6.50 (165.0)
3	4.09 (103.8)	11.40 (289.6)	5.92 (150.3)	1.77 (44.9)	10.81 (274.6)
5	7.00 (177.8)	17.81 (452.3)	8.08 (205.2)	6.00 (152.4)	16.01 (406.6)

Approximate Dimensions in Inches (mm)

Full Voltage Reversing Starters

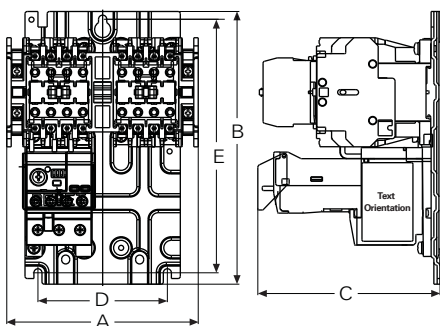

Sizes 00, 0

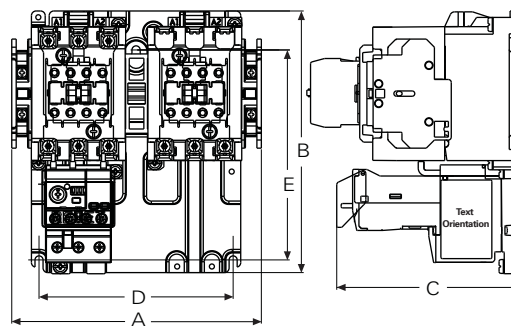

Size 1

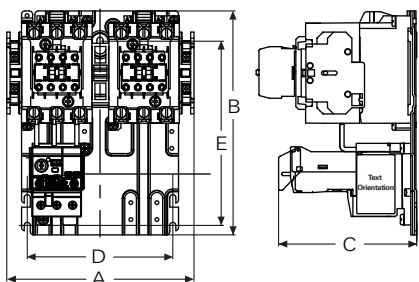

Size 2

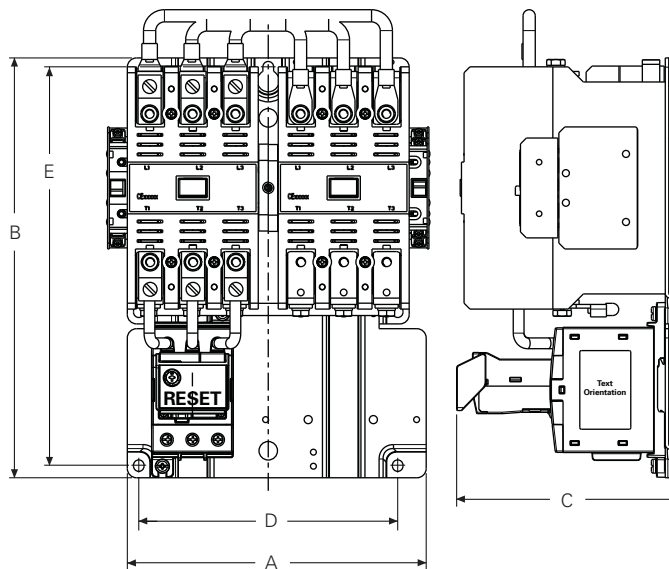

Size 3

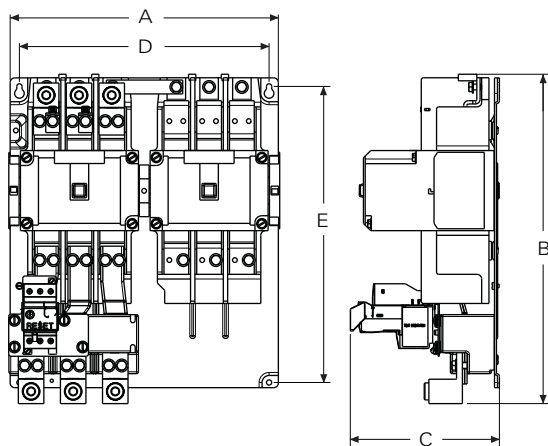

Size 5

NEMA Size	A	B	C	D	E
00, 0	5.20 (132.0)	7.40 (187.0)	4.90 (125.0)	3.50 (89.0)	6.90 (174.0)
1	6.70 (171.0)	7.10 (180.0)	4.98 (126.5)	5.25 (133.0)	5.70 (144.0)
2	6.70 (171.0)	8.10 (205.0)	4.98 (126.5)	5.25 (133.0)	6.70 (170.0)
3	8.08 (205.2)	11.35 (288.3)	6.00 (152.0)	7.00 (177.8)	10.77 (273.6)
5	14.50 (368.3)	17.81 (452.3)	8.06 (204.8)	13.50 (342.9)	16.00 (406.6)

Contactors—Non-Reversing and Reversing

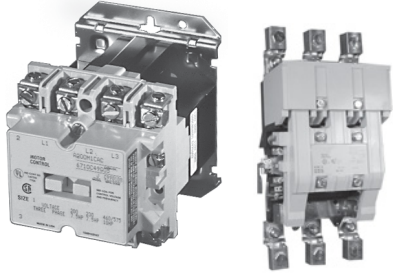

33

Contactors—Non-Reversing and Reversing

Product Description

Class A201 Contactors, Sizes 00–4; Three-Phase, 1-1/2–100 hp

A201 Magnetic Contactors from Eaton’s electrical sector are 600V rated devices available in NEMA Sizes 00–4, 10A through 150A (open rating). Product features include:

- Straight-through wiring to line and load terminals located up front for ease of installation
- Moving and stationary contacts are front accessible, simplifying inspection and maintenance
- Reliable U-shaped magnet for reduced power consumption
- Coil design reduces inventory/maintenance expenses. For a given voltage, one size coil fits all contactors Sizes 00–2, and a second coil fits three-pole Model J Sizes 3 and 4. Model K coils are different design

A201 contactors have normally open holding circuit interlocks which are supplied as standard.

Panel layout and drilling are simplified through the use

of common backplates, one for Sizes 00–2 and one for Sizes 3–4. In addition, panel space is reduced dramatically through the use of unique corner cavities for mounting the wide variety of modifications shown on **Page 83**.

For reversing applications, two contactors are supplied on a common base with electrical and mechanical interlocks which prevent both contactors from being closed at the same time.

Class A201 Contactors, Sizes 5–9; Three-Phase, Over 100 hp

These AC magnetic contactors utilize clapper design and feature straight-through wiring.

Contacts are silver alloy for longer life. The contacts close with optimum wiping action which serves to keep the contacting surfaces clean. De-ion® arc quenchers draw the arc away from the contacts at opening, which reduces burning and pitting and increases contact life.

All of the contactors are complete with one unwired, normally-open (NO) auxiliary contact mounted and have

Contents

Description

Page

A200 Series	
Contactors—Non-Reversing and Reversing	64
Starters—Non-Reversing and Reversing	70
Relays—Thermal and Fast Trip	91
Thermal Type B, Class 20, Manual Reset	93
Thermal Type A, Class 20, Auto/Manual Reset.	96
Type FT Fast Trip, Class 10	99
Heater Selection	102
Relays—Current Sensing Protective	104

accommodations for additional auxiliary contacts. No control circuit wiring or terminal markings are included.

Size 5, 300A, 600V, Open Size 6, 600A, 600V, Open

Class A201 Size 5 and 6 contactors are front clapper design, AC operated with the armature pivoting on dual needle bearings which assure accurate contact alignment.

The contactor base is molded of a high impact, non-tracking, non-hygroscopic glass polyester material permitting front mounting and wiring on a steel panel.

Floating magnet assures quiet operation.

Size 5 and 6 contactors must be mounted with the line terminals directly above the load terminals.

Multi-voltage coil ratings allow selection of the voltage which closely matches the actual system voltage to assure optimum contactor operation.

Each contactor accommodates two Type J11 auxiliary contacts, providing up to four auxiliary circuits, normally-open or normally-closed (NO and NC).

A201 Size 5 and 6 contactors and starters are UL recognized when supplied without terminals. When supplied with terminals, the devices are UL listed.

Two special configurations of the Class A201 Size 5 and 6 contactors are available:

- **Latched Design—**
This is a mechanically held, electrically released device. It is applied where the contactor must remain closed during extreme voltage fluctuations or power failure. It is also suitable for applications requiring quiet operation since the operating coil is de-energized when the contactor is closed. The latch assembly consists of a mechanical latch mechanism, electrically operated AC trip solenoid and a clearing contact
- **DC Operated—**This device is DC operated. It is used where low dropout voltage or exceptionally quiet operation is desired. The DC assembly consists of a DC operating coil, integrally mounted rectifier and shorting contact

**Size 7, 900A, 600V, Open
Size 8, 1350A, 600V, Open
Size 9, 2500A, 600V, Open**

Class A201 Size 7 and 8 contactors are DC operated side clapper design with the shaft mounted on dual needle bearings to ensure positive contact alignment and long contact life.

A steel panel base permits mounting on angle or channel without additional support, for versatile low cost installation.

Each stationary contact assembly is mounted on an individual molded insulator. Each pair of contacts is surrounded by a De-ion grid type arc quencher for rapid and confined arc interruption and long contact life.

The shunt for each pole is made of flexible, braided copper cable for freedom of movement and long life.

The rugged DC operating coils are designed to operate at high temperature and insulated to meet Class H service.

An integrally mounted avalanche type silicon rectifier supplies DC coil voltage from the AC control circuit.

Sizes 7 and 8 accommodate three Type L-63 auxiliary contacts which are easily converted from normally-open to normally-closed, providing auxiliary circuit flexibility. Size 9 uses L-64 auxiliary contacts with a total of four circuits.

A201 Size 7, 8 and 9 contactors and starters are UL recognized when supplied without terminals. When supplied with terminals, the devices are UL listed.

Application Description

Magnetic contactors are used to switch transformers and capacitors and to control electrical power circuits such as heating, lighting and motors that require no overload protection, or where overload protection is separately provided. They can be operated remotely by manual or automatic pilot devices.

Standards and Certifications

A201 contactors are UL listed components and also have CSA certification.

**Instructional Leaflets**

- 16960B Sizes 00–1 Magnetic Contactor, Non-reversing or Reversing
- 16961E Size 2 Magnetic Contactor, Non-reversing or Reversing
- 13238G Size 3 Magnetic Contactor, Non-reversing or Reversing
- 17001C Size 4 Magnetic Contactor, Non-reversing or Reversing
- 17049D Size 5 Magnetic Contactor, Non-reversing or Reversing
- 17053B Size 6 Magnetic Contactor, Non-reversing or Reversing
- 17048 Sizes 7–8 Magnetic Contactor, Non-reversing or Reversing
- 16978 Size 9 Magnetic Contactor, Non-reversing or Reversing

33.2

NEMA Contactors and Starters

A200 Series

Product Selection

Non-Reversing, Sizes 00–9

When Ordering Specify

Order by catalog number from the table below, plus suffix for coil voltages, verifying usage of appropriate sizes.

33

A201 Size 1 Contactor



Front Connected Contactors

Size	Amps	Max. UL Horsepower				480V	600V	Two Poles Open	Three Poles Open	Four Poles Open	Five Poles Open
		Single-Phase		Three-Phase				Catalog Number	Catalog Number	Catalog Number	Catalog Number
		115V	230V	208V	240V						
Sizes 00–6											
00	9	1/3	1	1-1/2	1-1/2	2	2	A201KAB_	A201KAC_	A201KAD_	A201KAE_
0	18	1	2	3	3	5	5	A201K0B_	A201K0C_	A201K0D_	A201K0E_
1	27	2	3	7-1/2	7-1/2	10	10	A201K1B_	A201K1C_	A201K1D_	A201K1E_
2	45	3	7-1/2	10	15	25	25	A201K2B_	A201K2C_	A201K2D_	A201K2E_
3	90	—	—	25	30	50	50	A201K3B_	A201K3C_	A201K3D_	A201K3E_
4	135	—	—	40	50	100	100	A201K4B_	A201K4C_	A201K4D_	A201K4E_
5	270	—	—	75	100	200	200	A201K5B_	A201K5C_	—	—
6	540	—	—	150	200	400	400	A201K6B_	A201K6C_	—	—
Sizes 7–9											
7 ^①	810	—	—	200	300	600	600	A201K7B_	A201K7C_	—	—
8 ^①	1215	—	—	400	450	900	900	A201K8B_	A201K8C_	—	—
9 ^①	2250	—	—	—	800	1600	—	A201K9B_	A201K9C_Z1 ^{②③}	—	—

Rear Connected Contactors

120V Rectified Coil/Open Only

Size	Catalog Number
7	A201K7CJZ1Z4
8	A201K8CJZ1Z4
9	A201K9CJZ1Z4

Coil Suffix

Coil Volts and Hz	Code Suffix
Sizes 00–6	
120/60 or 110/50	A
200–208/60	B
240/60	W
Sizes 7, 8 and 9^②	
480/60	X
600/60	E
110–120/50 or 60	J
220–240/50 or 60	K
440–480/50 or 60	U
600/60	E

Notes

- ① Sizes 7–9 use rectifier with DC coil.
- ② For Size 9, only available coil voltage is 120V.
- ③ Supplied without terminal lugs.

Reversing, Sizes 00–9

When Ordering Specify

Order by catalog number from the table below, plus suffix for coil voltages, verifying usage of appropriate sizes.

Size 1 Horizontal Reversing Contactor



Class A211—Horizontally Mounted and Class A251—Vertically Mounted Reversing Contactors

Size	Amps	Max. UL Horsepower						Horizontal Design	Vertical Design		
		Single-Phase		Three-Phase		208V	240V	480V	600V	Catalog Number	Catalog Number
		115V	230V								
Sizes 0–6											
0	18	1	2	3	3	5	5	A211K0C_	A251K0C_		
1	27	2	3	7-1/2	7-1/2	10	10	A211K1C_	A251K1C_		
2	45	3	7-1/2	10	15	25	25	A211K2C_	A251K2C_		
3	90	—	—	25	30	50	50	A211K3C_	A251K3C_		
4	135	—	—	40	50	100	100	A211K4C_	A251K4C_		
5	270	—	—	75	100	200	200	A211K5C_	A251K5C_		
6	540	—	—	150	200	400	400	A211K6C_	A251K6C_		
Sizes 7–9											
7 ^①	810	—	—	200	300	600	600	—	A251K7C_		
8 ^①	1215	—	—	400	450	900	900	—	A251K8C_		
9 ^①	2250	—	—	—	800	1600	—	—	A251K9C_ ^②		

Coil Suffix

Coil Volts and Hz	Code Suffix
Sizes 00–6	
120/60 or 110/50	A
200–208/60	B
240/60	W
480/60	X
600/60	E
Sizes 7, 8 and 9^②	
110–120/50 or 60	J
220–240/50 or 60	K
440–480/50 or 60	U
600/60	E

Notes

- ① Sizes 7–9 use rectifier with DC coil.
- ② For Size 9, only available coil voltage is 120V.

33.2

NEMA Contactors and Starters

A200 Series

Dimensions

Approximate Dimensions in Inches (mm)

Not to be used for construction purposes unless approved.

33

Non-Reversing Open Contactors

Figure A—Sizes 00–4 A210

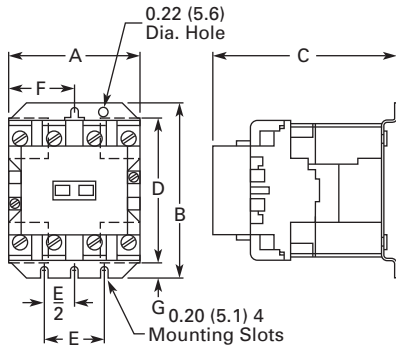

Figure B—Size 5

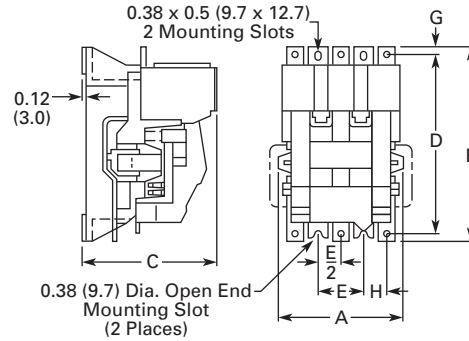

Figure C—Size 6

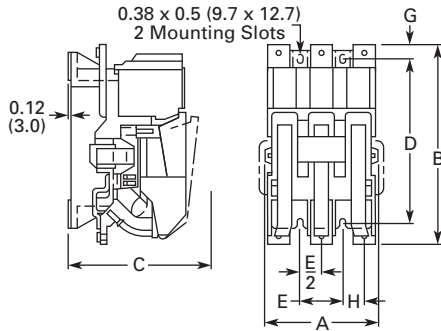
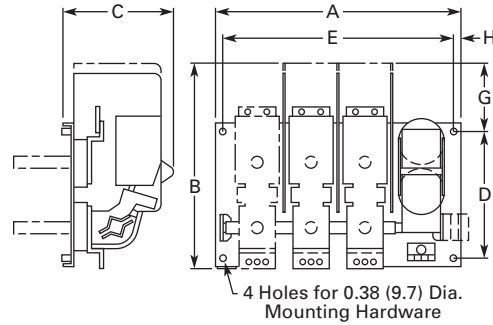

Figure D—Sizes 7–9



Dimensions and Shipping Weights

NEMA Size	No. of Poles	Fig.	Mounting Screws		A	B	C	D	E	F	G	H	Weight, Lbs (kg)
			No.	Size									
00, 0, 1	2–4	A	3	#10	3.31 (84.1)	4.38 (111.3)	4.61 (117.1)	3.95 (100.3)	1.50 (38.1)	1.66 (42.2)	0.23 (5.8)	—	2.6 (1.2)
	5	A	3	#10	4.19 (106.4)	4.38 (111.3)	4.61 (117.1)	3.95 (100.3)	1.50 (38.1)	2.09 (53.1)	0.23 (5.8)	—	3.2 (1.5)
2	2, 3	A	3	#10	3.31 (84.1)	4.38 (111.3)	4.94 (125.5)	3.95 (100.3)	1.50 (38.1)	1.66 (42.2)	0.23 (5.8)	—	3.3 (1.5)
	4, 5	A	3	#10	5.06 (128.5)	4.38 (111.3)	4.94 (125.5)	3.95 (100.3)	1.50 (38.1)	2.53 (64.3)	0.23 (5.8)	—	4.5 (2.0)
3, 4	2, 3	A	3	1/4 in.	4.63 (117.6)	6.63 (168.4)	6.75 (171.5)	6.00 (152.4)	1.88 (47.8)	2.31 (58.7)	0.38 (9.7)	—	9.3 (4.2)
	4, 5	A	3	1/4 in.	7.25 (184.2)	6.63 (168.4)	6.75 (171.5)	6.00 (152.4)	1.88 (47.8)	3.63 (92.2)	0.38 (9.7)	—	13.0 (5.9)
5	2, 3	B	4	3/8 in.	7.22 (183.4)	12.00 (304.8)	7.75 (196.9)	11.00 (279.4)	2.75 (69.9)	—	0.59 (15.0)	2.22 (56.4)	25.0 (11.4)
6	2, 3	C	4	3/8 in.	7.22 (183.4)	13.50 (342.9)	9.50 (251.3)	11.00 (279.4)	2.75 (69.9)	—	0.59 (15.0)	2.22 (56.4)	42.0 (19.1)
7	3	D	4	3/8 in.	23.50 (596.9)	18.63 (473.2)	11.00 (279.4)	12.00 (304.8)	22.00 (558.8)	—	5.63 (143.0)	0.75 (19.1)	215.0 (97.6)
8	3	D	4	3/8 in.	23.50 (596.9)	19.25 (489.0)	11.00 (279.4)	12.00 (304.8)	22.00 (558.8)	—	5.63 (143.0)	0.75 (19.1)	265.0 (120.3)
9	3	D	4	1/2 in.	33.00 (838.2)	29.75 (755.7)	12.94 (328.7)	8.00 (203.2)	30.75 (781.1)	—	14.50 (368.3)	1.63 (41.4)	315.0 (143.0)

Approximate Dimensions in Inches (mm)

Not to be used for construction purposes unless approved.

Reversing Open Contactors

Figure A—Sizes 00–4 Horizontal

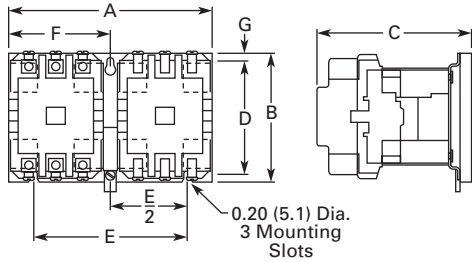

Figure C—Sizes 5, 6 Horizontal

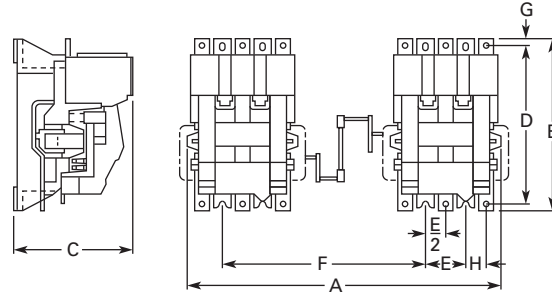

Figure B—Sizes 00–4 Vertical

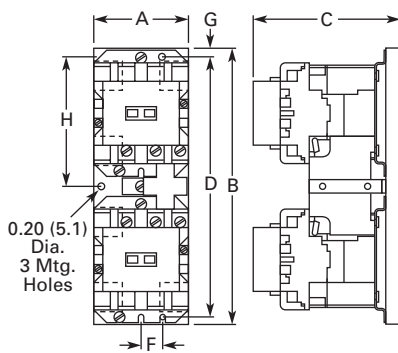

Figure D—Sizes 5, 6 Vertical

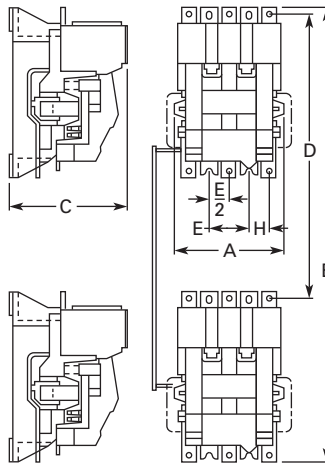
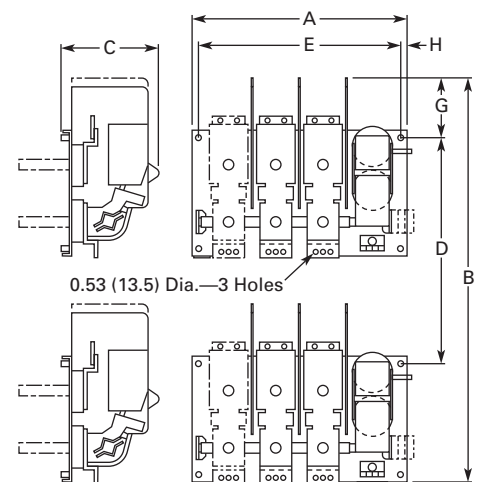

Figure E—Sizes 7–9 Vertical



Dimensions and Shipping Weights

NEMA Size	No. of Poles	Fig.	Mounting Screws		A	B	C	D	E	F	G	H	Weight, Lbs (kg)
			No.	Size									
00, 0, 1	3 x 3 H.	A	3	#10	7.13 (181.1)	4.45 (113.0)	5.05 (128.3)	3.95 (100.3)	5.31 (134.9)	3.56 (90.4)	0.25 (6.4)	—	7.8 (3.5)
	3 x 3 V.	B	3	#10	3.33 (84.6)	9.61 (244.1)	5.05 (128.3)	9.08 (230.6)	2.16 (54.9)	0.75 (19.1)	0.25 (6.4)	4.52 (114.8)	8.9 (4.0)
2	3 x 3 H.	A	3	#10	7.13 (181.1)	4.45 (113.0)	5.38 (136.7)	3.95 (100.3)	5.31 (134.9)	3.56 (90.4)	0.25 (6.4)	—	9.1 (4.1)
	3 x 3 V.	B	3	#10	3.33 (84.6)	9.61 (244.1)	5.38 (136.7)	9.08 (230.6)	2.16 (54.9)	0.75 (19.1)	0.25 (6.4)	4.52 (114.8)	10.0 (4.5)
3, 4	3 x 3 H.	A	3	1/4 in.	9.75 (247.7)	6.88 (174.8)	7.25 (184.2)	6.00 (152.4)	7.00 (177.8)	4.88 (124.0)	0.44 (11.2)	—	24.0 (10.9)
	3 x 3 V.	B	3	1/4 in.	4.63 (117.6)	16.56 (420.6)	7.25 (184.2)	15.69 (398.5)	2.75 (69.9)	0.94 (23.9)	0.44 (11.2)	7.78 (197.6)	25.0 (11.4)
5	3 x 3 H.	C	8	3/8 in.	17.22 (437.4)	12.00 (304.8)	7.75 (196.9)	11.00 (279.4)	2.75 (69.9)	10.00 (254.0)	0.59 (15.0)	1.38 (35.1)	55.0 (25.0)
	3 x 3 V.	D	8	3/8 in.	8.25 (209.6)	30.00 (762.0)	7.75 (196.9)	18.00 (457.8)	2.75 (69.9)	—	—	1.38 (35.1)	55.0 (25.0)
6	3 x 3 H.	C	8	3/8 in.	17.22 (437.4)	13.50 (342.9)	8.75 (222.3)	11.00 (279.4)	2.75 (69.9)	10.00 (254.0)	0.59 (15.0)	1.38 (35.1)	90.0 (40.9)
	3 x 3 V.	D	8	3/8 in.	8.25 (209.6)	41.50 (1054.1)	8.75 (222.3)	28.00 (711.2)	2.75 (69.9)	—	—	1.38 (35.1)	90.0 (40.9)
7	3 x 3 V.	E	8	3/8 in.	23.50 (596.9)	38.63 (981.2)	11.00 (279.4)	20.00 (508.0)	22.00 (558.8)	—	5.63 (143.0)	0.75 (19.1)	450.0 (204.3)
8	3 x 3 V.	E	8	3/8 in.	23.50 (596.9)	39.25 (997.0)	11.00 (279.4)	20.00 (508.0)	22.00 (558.8)	—	5.63 (143.0)	0.75 (19.1)	550.0 (249.7)
9	3 x 3 V.	E	8	1/2 in.	33.00 (838.2)	62.75 (1593.9)	12.94 (328.7)	33.00 (838.2)	30.75 (781.1)	—	14.50 (368.3)	1.63 (41.4)	650.0 (295.1)

Starters—Non-Reversing and Reversing

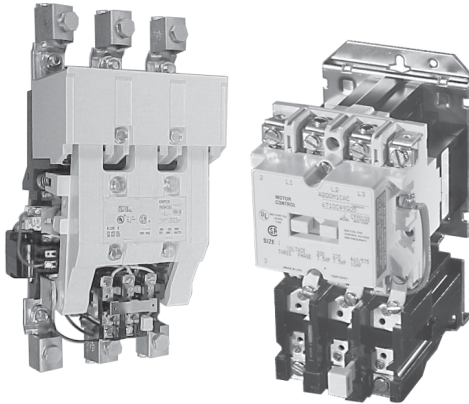

33

Contents

<i>Description</i>	<i>Page</i>
Contactors—Non-Reversing and Reversing	64
Starters—Non-Reversing and Reversing	
Application Description	71
Features and Benefits	71
Standards and Certifications	71
Instructional Leaflets	71
Product Selection	72
Accessories	75
Renewal Parts	78
Accessories and Field Modification Kits	83
Technical Data and Specifications	84
Mechanical Characteristics	86
Dimensions	88
Relays—Thermal and Fast Trip	91
Thermal Type B, Class 20, Manual Reset	93
Thermal Type A, Class 20, Auto/Manual Reset	96
Type FT Fast Trip, Class 10	99
Heater Selection	102
Relays—Current Sensing Protective	104

Starters—Non-Reversing and Reversing

Product Description

NEMA Sizes 00–4; Three-Phase, 1-1/2–100 hp

These Starters from Eaton's electrical sector use Class A201 contactors as described on **Page 64**. Contactor features are enhanced through the ability to provide positive motor protection in the form of several types of overload relays. See **Pages 91–103**.

Type B Overload Relay, Manual Reset Only

Supplied as standard on Class A200 and A900 starters (two-speed). The bi-metallic overload relay offers ambient compensation and trip-to-test feature (relay contact status check) as standard. In addition, an isolated normally-open contact is available in kit form for customer mounting. Type B overload relays are manual reset only.

Type A Overload Relay, Manual or Automatic Reset

This is an optional overload relay, offering the capability of field conversion to automatic reset. It is available

as an ambient compensated or non-compensated type.

Non-Reversing Starters

Non-reversing starters are supplied as open devices. All starters are supplied with a normally-open holding circuit interlock.

Reversing Starters

For reversing applications (Class A210), a starter and a contactor electrically and mechanically interlocked are supplied on a common baseplate. Reversing starters are used to start, stop and reverse AC squirrel cage motors and for primary control of reversing wound-rotor motors.

For plugging or inching, when operations exceed five times per minute, decreased horsepower ratings in accordance with NEMA Standard ICS 2-321 are recommended.

Two-Speed Starters, A900s

For across-the-line starting of two-speed constant hp, constant torque and variable

torque squirrel cage motors, two-speed starters (Class A900) are available. These starters consist of two starters, one for each motor speed, mechanically and electrically interlocked and wired for manual speed selection by means of pushbuttons. Auxiliary relays may be added to provide automatic acceleration or deceleration.

Starters for two-speed, two independent winding motors consist of two-, three- or four-pole starters electrically and mechanically interlocked.

Starters for two-speed, single reconnectable winding motors consist of one three-pole and one five-pole starter mechanically and electrically interlocked.

NEMA Sizes 5–9; Three-Phase 75 to 1600 hp

Non-reversing (Class A200), and reversing (Classes A210, A250) full voltage starters are used for across-the-line starting of squirrel cage

induction motors. They are used with motors rated above 50 hp at 230V, and above 100 hp at 460 through 600V.

Sizes 5 and 6 starters use Class A201 contactors as described on **Page 64**. In addition to standard motor starters, special application devices are available: Sizes 5 and 6 starters with integrally rectified AC to DC coils for applications where low voltage problems are prevalent are available.

Front Removable Parts—

All operating parts can be removed quickly and easily from the front. Straight-through wiring and conveniently located connection points for external wires and cables minimize installation time.

Type B Block Type Thermal Overload Relay—

Dependable overload protection is assured by these snap-action, manual reset relays. Automatic reset Type A relays are available as an option.

Types of Starters**Class A200, Sizes 5 and 6—**

Non-reversing starters contain an AC magnetically-operated Size 5 or Size 6 line contactor and block Type B three-pole overload relay, along with three current transformers. A control relay whose contacts handle the coil current of the starter is provided with Size 6 starters.

Class A200, Sizes 7, 8 and 9—

Non-reversing starters contain a DC operated line contactor, DC power supply, block Type B three-pole overload relay with three current transformers and a control relay.

Class A960/A970/A980 Multi-Speed Starters:
Refer to **Page 74**.**Application Description**

Magnetic starters are used for full-voltage, across-the-line starting and stopping of squirrel cage motors. They can be operated locally or remotely by manual or automatic pilot devices.

Features and Benefits**Sizes 00–4**

- **Straight-Through Wiring, Up-Front, Out-Front Terminals** for ease in installation
- **Unique Accessory Mounting Cavities** reduce panel space requirements
- **Snap-in Accessories** for application flexibility
- **Vertical and Horizontal Interlocking** capability increases application flexibility
- **Ambient Compensated Overload Relays** available as standard, offering superior motor protection in variable motor/controller environments
- **Isolated Normally Open Relay Contact** available in kit mounting form on Type B Overload Relay

Sizes 5–9

- **Rectified AC/DC Coils** available to reduce premature drop-out or “kiss” problems due to inherent low voltage conditions
- **Clapper Design** armature assembly pivots on needle bearings resulting in quick, smooth opening and closing of the magnet
- **Stainless Steel Kick-Out Spring** assures quick, positive drop-out time
- **Front Removable Parts** all current carrying parts front removable for easy inspection and maintenance

Standards and Certifications

Class A200 starters are UL listed and recognized and also carry CSA certification.

**Instructional Leaflets**

16958	Sizes 00–1, 3-Pole Motor Controller
16956	Sizes 00–1, 2-Pole, Single-Phase Motor Controller
16959	Size 2, 3-Pole Motor Controller
16957	Size 2, 2-Pole, Single-Phase Motor Controller
15465C	Sizes 3 and 4J Motor Controller
17000C	Size 4, Model K Motor Controller
17054C	Size 5 Motor Controller
17055C	Size 6 Motor Controller

33.2

NEMA Contactors and Starters

A200 Series

Product Selection

Non-Reversing, Sizes 00–9

When Ordering Specify

Order by catalog number from the tables to the right, plus suffix for coil voltages, verifying usage of appropriate sizes.

Heaters

Enter heaters as separate item by listing catalog number from the tables on **Pages 102 and 103**, as required per starter.

33

Size 3 Starter



Non-Reversing Starters

Size	Amperes	Max. UL Horsepower						Open Catalog Number ^①
		Single-Phase 115V	230V	Three-Phase 208V	240V	480V	600V	
Two-Poles^②—Sizes 00–2								
00	9	1/3	—	1-1/2	1-1/2	2	2	A200MABR
0	18	1	—	3	3	5	5	A200M0BR
1	27	2	—	7-1/2	7-1/2	10	10	A200M1BR
1-1/2	36	3	—	—	—	—	—	A200MDBR
2	45	7-12	—	10	15	25	25	A200M2BR
Three Poles—Sizes 00–6								
00	9	1/3	—	1-1/2	1-1/2	2	2	A200MAC_
0	18	1	—	3	3	5	5	A200M0C_
1	27	2	—	7-1/2	7-1/2	10	10	A200M1C_
2	45	7-12	—	10	15	25	25	A200M2C_
3	90	—	—	25	30	50	50	A200M3C_
4	135	—	—	40	50	100	100	A200M4C_
5	270	—	—	75	100	200	200	A200M5C_
6	540	—	—	150	200	400	400	A200M6C_
Three Poles—Sizes 7–9								
7 ^③	810	—	—	200	300	600	600	A200M7C_
8 ^③	1215	—	—	400	450	900	900	A200M8C_
9 ^③	2250	—	—	—	800	1600	—	A200M9C_^④

Coil Suffix

Coil Volts and Hz	Code Suffix
Sizes 00–6	
120/60 or 110/50	AC
200–208/60	B
240/60	W
480/60	X
600/60	E
Sizes 7, 8 and 9^④	
110–120/50 or 60	J
220–240/50 or 60	W
440–480/50 or 60	X
600/60	E

Notes

- ① For ambient compensated overload relay with auto-reset, add Suffix **D**.
- ② Single-phase with one single-pole overload relay.
- ③ Sizes 7–9 use rectifier with DC coil.
- ④ For Size 9, only available coil voltage is 120V.

Reversing, Sizes 00–9

When Ordering Specify

Order by catalog number from table below, plus suffix for coil voltages, verifying usage of appropriate sizes.

Heaters

Enter heaters as separate item by listing catalog number from the tables on **Pages 102 and 103**, as required per starter.

Size 1 Horizontal Reversing Starter

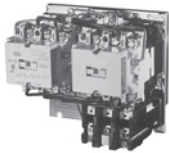

Reversing Starters

Size	Amps	Max. UL Horsepower						Horizontal Design	Vertical Design
		Single-Phase		Three-Phase				Catalog Number ①	Catalog Number ①
		115V	230V	208V	240V	480V	600V		
Sizes 00 –6									
00	9	1/3	1	1-1/2	1-1/2	2	2	A210MAC_	A250MAC_
0	18	1	2	3	3	5	5	A210M0C_	A250M0C_
1	27	2	3	7-1/2	7-1/2	10	10	A210M1C_	A250M1C_
2	45	3	7-1/2	10	15	25	25	A210M2C_	A250M2C_
3	90	—	—	25	30	50	50	A210M3C_	A250M3C_
4	135	—	—	40	50	100	100	A210M4C_	A250M4C_
5	270	—	—	75	100	200	200	A210M5C_	A250M5C_
6	540	—	—	150	200	400	400	A210M6C_	A250M6C_
Sizes 7–9									
7 ②	810	—	—	200	300	600	600	—	A250M7C_
8 ②	1215	—	—	400	450	900	900	—	A250M8C_
9 ②	2250	—	—	—	800	1600	—	—	A250M9C_ ③

Coil Suffix

Coil Volts and Hz	Code Suffix
Sizes 00–6	
120/60 or 110/50	AC
200–208/60	B
240/60	W
480/60	X
600/60	E
Sizes 7, 8 and 9 ③	
110–120/50 or 60	J
220–240/50 or 60	W
440–480/50 or 60	X
600/60	E

Notes

- ① For ambient compensated overload relay with auto-reset, add Suffix **D**.
- ② Sizes 7–9 use rectifier with DC coil.
- ③ For Size 9, only available coil voltage is 120V.

33.2

NEMA Contactors and Starters

A200 Series

33

For Separate Two-Winding Motors

Heaters

Enter heaters as separate item by listing catalog number from the tables on **Pages 102 and 103**, as required per starter.

Three-Phase, Non-Reversing, Reversing 60 Hz Starters—Heater Selection

NEMA	Amperes	Constant Horsepower				Constant or Variable Torque				Three Poles Open Catalog Number ^①
		208V	240V	480V	600V	208V	240V	480V	600V	
Sizes 0–6										
0	18	3	3	5	5	2	2	3	3	A960M0C_
1	27	7-1/2	7-1/2	10	10	5	5	7-1/2	7-1/2	A960M1C_
2	45	10	15	25	25	7-1/2	10	20	20	A960M2C_
3	90	25	30	50	50	20	25	40	40	A960M3C_
4	135	40	50	100	100	30	40	75	75	A960M4C_
5	270	75	100	200	200	60	75	150	150	A960M5C_
6	540	150	200	400	400	100	150	300	300	A960M6C_

For Single-Winding Motors

Sizes 0–6

NEMA	Amperes					Three Poles Open Catalog Number ^①
		208V	240V	480V	600V	
Constant Horsepower						
0	18	3	3	5	5	A970M0C_
1	27	7-1/2	7-1/2	10	10	A970M1C_
2	45	10	15	25	25	A970M2C_
3	90	25	30	50	50	A970M3C_
4	135	40	50	100	100	A970M4C_
5	270	75	100	200	200	A970M5C_
6	540	150	200	400	400	A970M6C_
Constant or Variable Torque						
0	18	2	2	3	3	A980M0C_
1	27	5	5	7-1/2	7-1/2	A980M1C_
2	45	7-1/2	10	20	20	A980M2C_
3	90	20	25	40	40	A980M3C_
4	135	30	40	75	75	A980M4C_
5	270	60	75	150	150	A980M5C_
6	540	100	150	300	300	A980M6C_

Coil Suffix

Coil Volts and Hz	Coil Suffix
Sizes 0–6	
120/60 or 110/50	AC
200–208/60	B
240/60	W
480/60	X
600/60	E

Note

^① For ambient compensated overload relay with auto-reset, add Suffix **D**.

Accessories

SS-56 Surge Suppressor

- Designed to be used with magnetic motor controllers through Size 4 in 120V, 60 Hz control circuit applications where electronic equipment is used
- Steady state coil volts: 120, 60 Hz, rms
- Peak input volts: 169.6, 60 Hz, max. amplitude
- Max. ambient temperature: 65°C
- Nominal limiting volts: 270 peak
- Nominal rate of volt rise: 0.5 per ms

SS-56 Surge Suppressor



Surge Suppressor ①

Type	Mounting	Kit Catalog Number
Starter		SS-56

Mechanical Interlock

- Prevents closing of one member of a reversing or multi-speed contactor until the opposite member is completely open
- Lever type mechanism assures positive action
- Can be factory assembled or field mounted on A200 and A900 starters and contactors

Mechanical Interlock

Contactors Arrangement (Number of Poles, Horizontal or Vertical)	Continuous Size	Interlock Catalog Number
3 x 3 horizontal	0, 1	M-33-1B
4 x 4 horizontal	0, 1	M-33-1B
5 x 3 horizontal	0, 1	M-33-1B
All pole combination, vertical	0, 1	M-34-1A
3 x 3 horizontal reversing	2	M-33-2B
3 x 3 vertical reversing	2	M-34-2A
5 x 3 horizontal	2	M-35-2A
4 x 4 horizontal	2	M-36-2A
All pole combination horizontal	3, 4	M-33-3B
All pole combination vertical	3, 4	M-34-3

F-56 Fuse Block

- Facilitates installation of fuses (15A, 600V max.) in control circuits
- Utilizes Bussman type KTK fuses, or equivalent
- Mounts in same cavity as Type J auxiliary contact
- No tools or mounting hardware needed
- Fuse not included

Fuse Block

Mounting	Kit Catalog Number
Starter	F56
Panel	F56-P

R-56 Interposing Relay

The R-56AA interposing relay is a low energy solid-state device with a single NO solid-state contact. It can be used as a 120 Vac control relay, and will operate on as little as 40 Vac input. Is useful in

applications requiring long control wiring runs where excessive voltage drop would prevent the contactor or relay from energizing. Will operate a Size 4 contactor from 10,000 feet using 18 AWG wire.

Interposing Relay

Type	Mounting	Kit Catalog Number
Starter or panel		R56-AA

B3NO Bell Alarm Contact

- Isolated normally open bell alarm contact
- Mounts in Type B block-type overload relay

Bell Alarm Contact

Kit Catalog Number
B3NO-2
B3NO-4 ②

Control Contact Ratings (B600)

AC Volts	Maximum Amperes	
	Make	Break
24–120	30	3.00
121–600	3600 VA	360 VA

Continuous current rating: 5A

Overload Relay Reset Extension

- Used to adjust overload reset rod depth of Class A200 Model J starters and current design overload relays to same dimensions as obsolete B200 starters and overloads identified by suffix **B**, i.e., BA13**B**
- When replacing obsolete B200 device with Class A200 starter and Type B overload, order Style 6710C11H03. No charge.
- When replacing obsolete B200 device with Class A200 starter and Type A overload, order Style 1490C15H10. No charge.

Notes

- ① Can be used on Sizes 5 and 6 with 120V coil. Mounting bracket required—order separately. Mounting bracket 177C043G04.
- ② For Size 3 and 4.

Power Pole Kit

- Adds 1NO or 1NC power pole to Size 00–1 A201 Class contactors
- Factory installed or field mountable in load side auxiliary cavities
- 600V AC
- Continuous current rating of 18A for Size 0, 27A for Size 1

Power Pole Kit ①

Continuous Current Rating	Kit Size	Kit Catalog Number
Normally Open		
18	0	PNO-0
27	1	PNO-1
Normally Closed		
18	0	PNC-0
27	1	PNC-1

Replacement Auxiliary Contacts

Contactor Size	Contact Arrangement	Auxiliary Elect. Contact	
		Catalog Number	Style Number
5, 6	1NO + 1NC	J11	9084A17G01
	2NO	J20	9084A17G02
	2NC	J02	9084A17G03
7, 8	1NO	—	578D461G01
	1NC	—	578D461G03
9	1NO + 1NC	—	843D943G04
	2NO	—	843D943G05
	2NC	—	843D943G06

Extra Auxiliary Contact Kits

All starters include an auxiliary contact with 1NO and 1NC contact. These kits include an auxiliary contact with contacts

as shown, plus operating arm and mounting bracket when required.

Extra Auxiliary Contact Kits

Contactor Size	Contact Arrangement	Style Number
5, 6	1NO + 1NC	3463D94G18
	2NO	3463D94G04
	2NC	3463D94G19
7, 8 ^②	2NO	818D498G06
	1NO	818D498G04

DC Coil Conversion Kits

Kits listed below include all necessary parts to convert from AC to DC control including the DC coil with

built-in diode, rectifier, auxiliary interlock and all mounting hardware.

DC Coil Conversion Kits

Size	Voltage	Kit Style Number
5	110-120	7864A28G01
	220-240	7864A28G02
	440-480	7864A28G03
6	110-120	7864A29G01
	220-240	7864A29G02
	440-480	7864A29G03

Mechanical Interlocks

Contactor Sizes	Style Numbers	
	Horizontal	Vertical
3, 4 and 5	2050A11G75	2050A11G65
5 and 5	2050A11G27	2050A11G17
5 and 6	2050A11G26	2050A11G16
6 and 7, 8	—	2050A11G55
7, 8 and 7, 8	No (rear conn.)	567D624G01
7, 8 and 9	No (rear conn.)	9944D56G06
9 and 9	No (rear conn.)	9944D56G01

Notes

- ① Do not use with DC operated contactors.
 ② Size 7 and larger use DC coils as standard.

Overload Protection

Overload Protection Size 5 Starters

Type B overload relay is a three-pole, block type, thermal ambient compensated device with manual reset mounted integrally. Current transformers are enclosed in a protective case and integrally mounted to save panel space. Standard ratio is 300:5.

panel which connects directly to the load terminal of the contactor. Current transformers are 600:5 ratio as standard.

If automatic reset is required, the Type A, three-pole block, ambient compensated relay is available upon request.

Overload Protection Size 6 Starters

Overload protection assembly consists of three current transformers, Type B three-pole block overload relay and an optional interposing relay. These parts are mounted on a

Overload Relay Kits

Each kit includes three current transformers (standard ratio) and one Type B, three-pole block overload relay, ambient compensated with manual reset.

Overload Relay Kits

Kit Size	Kit Part Number
5	2057A34G01
6	6379D80G10

Replacement Terminal Lugs ①

Contactor Size	Cable Size	Terminals		Kit Style Number
		Quantity in Kit	Quantity Required per Pole	
5	1-500 MCM	6	2	2119A76G01
6	2-500 MCM	6	2	7858A96G01
7	4-500 MCM	12	4	7858A96G02
8	4-500 MCM	12	4	7858A96G03

Note

① All mounting hardware is included in kit.

Renewal Parts

When Ordering Specify

Use this renewal parts data to identify device by style number, catalog number and/or description.

Select style number of replacement part from the following pages.

For clarification of ordering procedure, pricing and discounts, contact the Customer Support Center.

General Information

This renewal parts data will provide the proper identification of standard parts which may be required for maintenance of Eaton's components.

It is the intent of this catalog section to make it possible to quickly select the parts needed.

An investment in renewal parts and regular maintenance program will

protect against downtime and ensure a proper duty cycle for your equipment.

To maintain maximum operating efficiency and dependability of your equipment, only genuine Eaton replacement parts should be used.

This section identifies the replacements parts which are available. Order by style number.

JF Autostarters

JF Autostarter Kits ①

Frame Size	Start Contacts		Run Contacts		Grid Stack Kit	
	Required	Style Number	Required	Style Number	Required	Style Number
2-3	1	38A7018G12	1	38A7018G13	1	3354D90G10
4-5 5L	1	550D409G18	1	550D409G19	1	3354D90G10
5M-5MM	1	3354D90G08	1	3354D90G09	2	3354D90G10

Solenoid Assembly with Coil (All Sizes) ②

Volt	Hz	Style Number ③
115	60	5264C05H01
230	60	5264C05H02
460	60	5264C05H03
575	60	5264C05H04

Notes

- ① Kits contain a complete set of moving contacts, stationary contacts and springs.
- ② When replacing solenoid assembly series 416C160 use adapter plate style 9917D02H01—one required.
- ③ These styles replace coil style 296B892G___. When ordering new style as replacement, customer must order adapter plate 9917D02H01, one required.

AC Starters, Contactors A200, A201

AC Contactors Model J Sizes 00, 0, 1, 2 Kits ①

Part	Poles	Size 00	Size 0	Size 1	Size 2
		Style Number	Style Number	Style Number	Style Number
Contact kit	2	373B331G17	373B331G02	373B331G07	373B331G11
	3	373B331G18	373B331G04	373B331G09	373B331G12
	4	373B331G18	373B331G04	373B331G09	373B331G13 ③
	5	373B331G19	373B331G05	373B331G10	—
Arc box ②	2, 3, 4	6714C74G01	6714C74G02	6714C74G03	6714C74G07 ④
	5	6714C74G04	6714C74G05	6714C74G06	6714C74G08 ⑤
Cross bar	2, 3	N/A	N/A	N/A	672B788G32
	4, 5	N/A	N/A	N/A	672B788G34
Upper base (for single rated coils only)	2, 3	N/A	N/A	N/A	672B788G33
	4, 5	N/A	N/A	N/A	672B788G35
Lower base	2, 3	N/A	N/A	N/A	1250C33G09
	4, 5	N/A	N/A	N/A	1250C33G05
KO spring (package of 10)	All	N/A	N/A	N/A	503C796G01
Terminal line/load (package of 3)	All	N/A	N/A	N/A	371B870G03

AC Coils

Voltage	Hz	Size 00, 0, 1	Five-Pole	Size 2	Four-, Five-Pole
		Two-, Three-, Four-Pole		Two-, Three-Pole	
		Style Number	Style Number	Style Number	Style Number
120/110	60/50	505C806G01	505C808G01	505C806G01	505C818G01
208	60	505C806G02	505C808G02	505C806G02	505C818G02
600/550	60/50	505C806G05	505C808G05	505C806G05	505C818G05
380	50	505C806G07	505C808G07	505C806G07	505C818G07
240/220	60/50	505C806G12	505C808G12	505C806G12	505C818G12
480/440	60/50	505C806G13	505C808G13	505C806G13	505C818G13
24	60	505C806G16	N/A	505C806G16	505C818G15
277	60	505C806G18	505C808G16	505C806G18	505C818G16
240/480 ⑥	60/60	505C806G03	505C808G03	505C806G03	505C818G03
120/240 ⑦	60/60	505C806G10	505C808G10	505C806G10	505C818G10

DC Coil ⑦

Voltage	Size 0, 1	Size 2
	Single-, Two-, Three-, Four-Pole	Single-, Two-, Three-Pole
Style Number		
12	1268C86G07	1268C86G07
24	1268C86G04	1268C86G04
48	1268C86G05	1268C86G05
125	1268C86G02	1268C86G02
250	1268C86G01	1268C86G01
125/250 ⑥	1268C86G03	1268C86G03

Notes

- ① Model C contact tips and coils 00-4, two-, three-, four- and five-pole contactors are same as Model J. All other parts are unavailable.
- ② Mounting hardware included.
- ③ Use one each of 373B331G11 and 373B331G12.
- ④ Two-, three-pole.
- ⑤ Four-, five-pole.
- ⑥ Dual voltage coils. Use only on contactors or starters originally supplied with a dual voltage coil.
- ⑦ Use only on contactors originally supplied with a DC coil.

Accessories for Size 5–9 AC Contactors

A rectifier circuit converts the AC supply to DC supply. This conversion provides pick up and drop out characteristics. All necessary parts are included in the kit.

AC-DC Coil Conversion Kits

Voltage	Size 5	Size 6
	Style Number	Style Number
120 Vac	7864A28G01	7864A29G01
240 Vac	7864A28G02	7864A29G02
480 Vac	7864A28G03	7864A29G03

Replacement Coils for AC-DC Coil Conversion Kit

Voltage	Size 5	Size 6
	Style Number	Style Number
120 Vac	7856A15G05	7856A16G05
240 Vac	7856A15G10	7856A16G10
480 Vac	7856A15G15	7856A16G15

Auxiliary Electrical Interlocks Size 7–9 AC and All DC Units

Type	Circuits	Application	Style Number
L63	NO	Size 7–8	578D461G01
L63	NC	Size 7–8	578D461G03
L64	NO-NC	Size 9	843D943G04
L64	2NO	Size 9	843D943G05
L64	2NC	Size 9	843D943G06

Model J–K, Sizes 3 and 4

Sizes 3 and 4 Kits ^①

Part	Poles	Size 3–Model J	Size 4–Model J ^②	Size 4–Model K ^③
		Style Number	Style Number	Style Number
Contact kit	2	626B187G12	626B187G16	5250C81G16
	3	626B187G13	626B187G17	5250C81G17
	4	^④	^⑥	5250C81G18
	5	^⑤	^⑦	5250C81G19
Arc box	2, 3	6714C74G09	6714C74G11	6714C74G11
	4, 5	6714C74G10	6714C74G12	6714C74G12
Cross bar	2, 3	672B788G36	672B788G36	672B788G40
	4, 5	672B788G38	672B788G38	—
Upper base	2, 3	672B788G37	672B788G37	672B788G52
	4, 5	672B788G39	672B788G39	—
Lower base	2, 3	1250C33G03	1250C33G03	1250C33G10
	4, 5	1250C33G06	1250C33G06	—
KO spring (package of 10)	All	503C796G02	503C796G02	672B788G50
Terminal line/load (package of 3)	All	372B357G12	372B357G18	372B357G18

Notes

- ① Model C contact tips and coils 00-4, two-, three-, four- and five-pole contactors are same as Model J. All other parts are unavailable.
- ② For 200A A202 magnetically latched lighting contactors order three-pole contact kit style 672B788G07.
- ③ Model K replaces Model J, offering superior design life characteristics. Renewal parts are different. Use parts for proper model only.
- ④ Use quantity two of 626B187G12.
- ⑤ Use quantity one each of 626B187G12 and 626B187G13.
- ⑥ Use quantity two of 626B187G16.
- ⑦ Use quantity one each of 626B187G16 and 626B187G17.

Accessories for Size 00–6 AC Contactors

Auxiliary Electrical Interlocks

Catalog Number (Obsolete)	Style Number (Obsolete)	Circuits	Catalog Number Current	Style Number Current
(L-56)	(2609D01G01)	1NO and 1NC	J11	9084A17G01
(L-56D)	(2609D01G02)	2NO	J20	9084A17G02
(L-56E)	(2609D01G03)	1NO and 1NC	J11	9084A17G01
(L-56B)	(2609D01G04)	2NO	J20	9084A17G02
(L-56H)	(2609D01G05)	2NO	J20	9084A17G02
(L-56J)	(2609D01G06)	1NO and 1NC DB	J1C	9084A17G04
(L-56A)	(2609D01G07)	N/A	N/A	N/A
(L-56B)	(2609D01G08)	N/A	N/A	N/A
(L-56F)	(2609D01G09)	N/A	N/A	N/A
(L-56G)	(2609D01G10)	1NO and 1NC DB	J1C	9084A17G04
(L-56C)	(2609D01G11)	2NC	J02	9084A17G03
(L-56M)	(2609D01G12)	N/A	N/A	N/A
(L-56P)	(2609D01G17)	1NO and 1NC	J11	9084A17G01
(L-56R)	(2609D01G18)	2NC	J02	9084A17G03
(L-56S)	(2609D01G19)	1NO and 1NC	J11	9084A17G01

Accessories for Model J–K, Series 3, 4**DC Coils** ①

Voltage	Model J Size 3, 4 Two-, Three-Pole Style Number
24	1255C68G04
48	1255C68G05
125	1255C68G01
250	1255C68G02
125/250 ②	1255C68G03

AC Coils

Voltage	Hz	Model J Size 3, 4		Model K Size 4 ③	
		Two-, Three-Pole Style Number	Four-, Five-Pole Style Number	Two-, Three-Pole Style Number	Four-, Five-Pole Style Number
120/110	60/50	505C633G01	505C635G01	5250C79G01	5250C80G01
208	60	505C633G02	505C635G02	5250C79G02	5250C80G02
600/550	60/50	505C633G05	505C635G05	5250C79G05	5250C80G05
380	50	505C633G07	505C635G07	5250C79G07	5250C80G07
240/220	60/50	505C633G12	505C635G12	5250C79G12	5250C80G12
480/440	60/50	505C633G13	505C635G13	5250C79G13	5250C80G13
24	60	505C633G34	N/A	5250C79G34	N/A
277	60	505C633G14	N/A	5250C79G14	N/A
240/480 ②	60/60	505C633G03	505C635G03	5250C79G03	5250C80G03
120/244 ②	60/60	505C633G10	505C635G10	5250C79G10	5250C80G10

A201 Contactors—Size 5–9**GCA 530/630—GPD 7, 8, 9 Kits** ④

Part	Size 5 Style Number	Size 6 Style Number	Size 7 Style Number	Size 8 Style Number	Size 9 Style Number
Contact kit (one per pole)	477B477G05 ⑤	2066A10G11	461A757G17	646C829G05	5264C42G01 ⑥ 5264C42G02 ⑦
Arc box	2050A15G45	2066A10G45	831D580G01	831D580G01	9917D69G02
Magnet assembly	2050A15G46	2050A15G46	N/A	N/A	N/A
Mag. spg. kit	2050A15G47	2050A15G47	N/A	N/A	N/A
Acr cup kit	2050A15G48	N/A	N/A	N/A	N/A
Load conversion kit	2050A15G49	2066A10G49	N/A	N/A	N/A
Line conversion kit	2050A15G50	2066A10G50	N/A	N/A	N/A
K.O. spring–6	2050A15G51	2066A10G46	N/A	N/A	N/A
C.T. 300/5	655C285H03	N/A	N/A	N/A	N/A
C.T. 400/5	655C285H04	N/A	N/A	N/A	N/A
C.T. 600/5 ⑧	N/A	2066A10G18	N/A	N/A	N/A
C.T. 800/5 ⑧	N/A	2066A10G19	N/A	N/A	N/A
Phase barrier	N/A	N/A	640C441G01	640C441G01	5264C35G03 ⑨
Cross bar	2050A15G12	2066A10G15	N/A	N/A	N/A
Shunt	N/A	2066A10G48	650C129G01	646C831G02 ⑩	5264C39G02 ⑩

Notes

① Use only on units originally supplied with DC coil.

② Dual voltage coils. Use only on contactors or starters originally supplied with dual voltage coil.

③ Model K replaces Model J, offering superior design life characteristics. Renewal parts are different. Use parts for proper model only.

④ Catalog Number A201/A200 Series replaces GCA/GPD series. Renewal parts are the same.

⑤ Use 477B477G06 for silver tungsten applications.

⑥ R.C.

⑦ F.C.

⑧ C.T. kit which replaces the single molded 1 C.T. assembly used on the old size 6 airbreak. The kit includes a single molded 3 C.T. assembly, 2 bus bar and hardware. This C.T. kit also replaces the single molded 3 C.T. assembly used on the present size 6 airbreak and size vacuum.

⑨ Set of three.

⑩ Set of four.

33.2

NEMA Contactors and Starters

A200 Series

Accessories for A201 Contactors—Size 5–9

Coils (Sizes 5 and 6)

33

Voltage	Hz	Size 5 Style Number	Size 6 Style Number
Sizes 5 and 6			
110/120	60	2050A14G05	2050A12G05
110/120	50	2050A14G06	2050A12G06
200/208	50	2050A14G07	2050A12G07
220/240	50	2050A14G08	2050A12G08
200/208	60	2050A14G09	2050A12G09
220/240	60	2050A14G10	2050A12G10
277/303	60	2050A14G12	2050A12G12
380/415	50	2050A14G14	2050A12G14
440/480	60	2050A14G15	2050A12G15
440/480	50	2050A14G16	2050A12G16
550/600	60	2050A14G17	2050A12G17
550/600	50	2050A14G18	2050A12G18
380/415	60	2050A14G19	2050A12G19
120/240	60	2050A14G20	2050A12G20
24 DC	—	2050A14G21	2050A12G21
48 DC	—	2050A14G22	2050A12G22
125 DC	—	2050A14G25	2050A12G25
250 DC	—	2050A14G27	2050A12G27

Coils (Sizes 7–9)

Line Voltage	Style Number	Required
Sizes 7 and 8		
125 Vdc	438C805G04	2
230 Vdc	438C805G02	2
250 Vdc	438C805G03	2
110/120 Vac ^① ④	438C805G12	2
220/240 Vac ^② ④	438C805G11	2
380 Vac ^③ ④	438C805G15	2
440/480 Vac ^③ ④	438C805G10	2
550/575 Vac ^③ ④	438C805G13	2
Size 9		
110 Vdc	5264C34G01 ^⑤	—

Notes

- ① Rectifier 125V 2018A40G01 (one required).
- ② Rectifier 250V 2018A40G02 (one required).
- ③ Rectifier 600V 2018A40G03 (one required).
- ④ These coils require an external rectifier. If the rectifier needs replacement, order by the appropriate style number.
- ⑤ Contains coil and resistor.

Modifications

Factory Modifications

Modification	Description	Catalog Number Suffix	NEMA Size								
			00-1	2	3	4	5	6	7	8	9
Control circuit	1 Extra auxiliary contact (1NO-1NC) non-reversing, reversing, 2-speed unwired	J1	Consult sales office for pricing adders.								
	2 Extra auxiliary contact non-reversing, reversing, 2-speed unwired	J2	Consult sales office for pricing adders.								
	3 Extra auxiliary contact non-reversing, unwired	J3	Consult sales office for pricing adders.								
	4 Extra auxiliary contact non-reversing, unwired	J4	Consult sales office for pricing adders.								
	Wired for separate control (NC)	C	Consult sales office for pricing adders.								
	Omit control wiring (NC)	X	Consult sales office for pricing adders.								
Overload relays (substitutions)	Ambient compensated with auto reset (NC)	D	Consult sales office for pricing adders.								
	Fast trip—ambient compensated (specify motor FLA)	D7	Consult sales office for pricing adders.								
	Overload relay alarm contact (NO) per overload	E	Consult sales office for pricing adders.								

Accessories and Field Modification Kits

Type J Auxiliary Contact

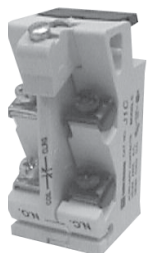

- Capable of being field mounted in a contactor or starter (Classes A200, A900 Sizes 00-6, V200, V201 vacuum and definite purpose controllers)
- Provides two separate electrical contact sets which wire vertically and are color coded; black designates NC and silver designates NO. Please note that the vertical wiring is contrary to the horizontal wiring of the L-56 auxiliary contacts
- Designed to fit within dimensions of starter; no additional panel space is required
- Provides circuit isolation (no polarity restrictions) and single break bifurcated contacts

Auxiliary Contact Ratings

Voltage	Make	Break
NEMA A600		
120-600 Vac	7200 VA	720 VA
72-120 Vac	60A	720 VA
28-72 Vac	60 VA	10A
NEMA R300		
28-300 Vdc	28 VA	28 VA

Auxiliary Contact Types

Contact Type	Max.	Catalog Number
1NO and 1NC	4	J11
2NC	4	J02
2NO	4	J20
1 coil clearing NC and 1NO	4	J1C

Technical Data and Specifications

Electrical Characteristics

Sizes 00–4

	Size 00	Size 0	Size 1	Size 2	Size 3	Size 4
Max. voltage rating	600V	600V	600V	600V	600V	600V
Ampere rating						
(Open)	10A	20A	30A	50A	100A	150A
(Enclosed)	9A	18A	27A	45A	90A	135A

Squirrel Cage Motor

Maximum horsepower at:

200V/60 Hz	1-1/2 hp	3 hp	7-1/2 hp	10 hp	25 hp	40 hp
230V/ 60 Hz	1-1/2 hp	3 hp	7-1/2 hp	15 hp	30 hp	50 hp
380V/50 Hz	1-1/2 hp	5 hp	10 hp	25 hp	50 hp	75 hp
460V–575V/60 Hz	2 hp	5 hp	10 hp	25 hp	50 hp	100 hp

Resistive Heating kW ^①

Single-phase, two-pole

120V	—	—	3 kW	5 kW	10 kW	15 kW
240V	—	—	6 kW	10 kW	20 kW	30 kW
480V	—	—	12 kW	20 kW	40 kW	60 kW
600V	—	—	15 kW	25 kW	50 kW	75 kW

Three-phase, three-pole

120V	—	—	5 kW	8.5 kW	17 kW	26 kW
240V	—	—	10 kW	17 kW	34 kW	68 kW
480V	—	—	20 kW	34 kW	68 kW	105 kW
600V	—	—	25 kW	43 kW	86 kW	130 kW

Capacitor Switching kVAR, Three-Phase

240V	—	—	—	12 kVAR	27 kVAR	40 kVAR
480V	—	—	—	25 kVAR	53 kVAR	80 kVAR
600V	—	—	—	31 kVAR	67 kVAR	100 kVAR

Transformer Switching kVA ^②

Single-phase, two-pole

120V	—	0.6 kVA	1.2 kVA	2.1 kVA	4.1 kVA	6.8 kVA
240V	—	1.2 kVA	2.4 kVA	4.1 kVA	8.1 kVA	14 kVA
480V	—	2.4 kVA	4.9 kVA	8.3 kVA	16 kVA	27 kVA
600V	—	3 kVA	6.2 kVA	10 kVA	20 kVA	34 kVA

Three-phase, three-pole

120V	—	1.8 kVA	3.6 kVA	6.3 kVA	12 kVA	20 kVA
240V	—	2.1 kVA	4.3 kVA	7.2 kVA	14 kVA	23 kVA
480V	—	4.2 kVA	8.5 kVA	14 kVA	28 kVA	47 kVA
600V	—	5.2 kVA	11 kVA	18 kVA	35 kVA	59 kVA

Sizes 5–9

	Size 5	Size 6	Size 7	Size 8	Size 9
Max. voltage rating	600V	600V	600V	600V	600V
Ampere rating					
(Open)	300A	600A	900A	1350A	2500A
(Enclosed)	270A	540A	810A	1215A	2250A

Squirrel Cage Motor

Maximum horsepower at:

200V/60 Hz	75 hp	150 hp	—	—	—
230V/60 Hz	100 hp	200 hp	300 hp	450 hp	800 hp
380V/50 Hz	150 hp	300 hp	—	—	—
460V–575V/60 Hz	200 hp	400 hp	600 hp	900 hp	1600 hp

Resistive Heating kW ^①

Single-phase, two-pole

120V	30 kW	60 kW	90 kW	③	③
240V	60 kW	120 kW	180 kW	③	③
480V	120 kW	240 kW	360 kW	③	③
600V	150 kW	300 kW	450 kW	③	③

Three-phase, three-pole

120V	52 kW	105 kW	155 kW	③	③
240V	105 kW	210 kW	315 kW	③	③
480V	210 kW	415 kW	625 kW	③	③
600V	260 kW	515 kW	775 kW	③	③

Capacitor Switching kVAR, Three-Phase

240V	80 kVAR	160 kVAR	240 kVAR	360 kVAR	665 kVAR
480V	160 kVAR	320 kVAR	480 kVAR	720 kVAR	1325 kVAR
600V	200 kVAR	400 kVAR	600 kVAR	900 kVAR	1670 kVAR

Transformer Switching kVA ^②

Single-phase, two-pole

120V	14 kVA	27 kVA	41 kVA	61 kVA	112 kVA
240V	27 kVA	54 kVA	81 kVA	122 kVA	225 kVA
480V	54 kVA	108 kVA	162 kVA	244 kVA	450 kVA
600V	68 kVA	135 kVA	203 kVA	304 kVA	562 kVA

Three-phase, three-pole

120V	41 kVA	81 kVA	122 kVA	182 kVA	337 kVA
240V	47 kVA	94 kVA	140 kVA	210 kVA	342 kVA
480V	94 kVA	188 kVA	280 kVA	420 kVA	783 kVA
600V	117 kVA	234 kVA	351 kVA	526 kVA	975 kVA

Notes

- ① Resistive loads having inrush currents not exceeding 1.5 times continuous rating.
- ② These ratings are for transformers having inrush currents not more than 20 times peak of continuous current ratings. For inrush currents greater than 20 times, refer to factory.
- ③ For ratings refer to factory.

DC Power Pole Ratings

The following represent typical production test values and should not be interpreted as a guarantee of actual performance.

DC Operated 120 and 240V Coils

Contactor Size	DC Contact Ampere Rating Two Poles in Series ^①	
	120V	240V
0	—	—
1	20	10
2	45	30
3	75	40
4	90	70

380V, 50 Hz Starter Maximum Horsepower Ratings**Horsepower Ratings**

NEMA Size	00	0	1	2	3	4	5	6	7	8
Maximum horsepower	1-1/2	5	10	25	50	75	150	300	450	700

Operating Coil Characteristics at Rated Coil Volts, Sizes 00–9

The following represent typical production test values and should not be interpreted as a guarantee of actual performance.

Operating Coil Characteristics

	Sizes 00, 0, 1	Size 2	Size 3	Size 4 ^②	Size 5	Size 6	Size 7	Size 8	Size 9
AC Coil									
Burden									
(Open VA)	160 VA	160 VA	625 VA	700 VA	1700 VA	2900 VA	③	③	③
(Closed VA)	25 VA	25 VA	50 VA	64 VA	180 VA	220 VA	③	③	③
(Closed Watts)	7.8 W	7.8 W	18 W	21 W	32 W	42 W	—	—	—
Pick-up volts ^④	85%	85%	85%	85%	78%	70%	—	—	—
Drop-out volts ^④	40–60%	40–60%	40–60%	40–60%	65 to 75%	60 to 70%	—	—	—
Pick-up time Hz ^{⑤⑥}	1–1-1/2	1-1/2–2	2–2-1/2	1–1-1/2	1.5	4.0	—	—	—
Drop-out time Hz ^⑤	3/4–1	3/4–1	3/4–1	3/4–1	0.75	0.75	—	—	—
DC Coil									
Burden									
(Open VA)	17 VA	17 VA	35 VA	35 VA	600 VA	2120 VA	400 VA	400 VA	2100 VA
(Closed VA)	17 VA	17 VA	35 VA	35 VA	22 VA	21 VA	400 VA	400 VA	350 VA
(Closed Watts)	18 W	18 W	35 W	35 W	20 W	20 W	400 W	400 W	350 W
Pick-Up Volts ^④	80%	80%	80%	80%	64%	73%	45%–65% ^⑦	45%–65% ^⑦	50%–65% ^⑦
Drop-Out Volts ^④	5–10%	5–10%	5–10%	5–10%	18%	13%	30%–45% ^⑦	30%–45% ^⑦	40%–50% ^⑦
Pick-Up Time Hz ^⑥	—	25–75 ms	25–75 ms	25–75 ms	2.7 Hz ^⑥	3 Hz ^⑥	21–41 Hz ^{⑦⑧}	17–29 Hz ^{⑦⑧}	16–18 Hz ^{⑦⑧}
Drop-Out Time Hz ^⑥	—	16–25 ms	16–25 ms	16–25 ms	9.3 Hz ^⑥	17.5 Hz ^⑥	7–12 Hz ^{⑧⑨}	7–12 Hz ^{⑧⑨}	18–20 Hz ^{⑦⑧}

Notes

- ① Non-inductive load.
- ② AC coil data pertains to Model K, DC coil data pertains to Model J.
- ③ DC operated only.
- ④ Percent of rated coil voltage.
- ⑤ At 60 Hz base.
- ⑥ To contact touch.
- ⑦ Lower figure when coil is cold. Higher figure when coil is hot.
- ⑧ Drop-out time to clear arc. Time varies with type of load and contact wear.

Mechanical Characteristics

NEMA Standard ICS 2-110

Direct-current operated contactors shall withstand 110% of their rated voltage continuously without injury to the operating coils and shall close successfully at 80% of their rated voltage.

Alternating-current operated contactors shall withstand 110% of their rated voltage continuously without injury to the operating coils and shall close successfully at 85% of their rated voltage.

Mechanical Characteristics, Sizes 00–9

	Sizes 00, 0, 1	Size 2	Size 3	Size 4	Size 5	Size 6	Size 7	Size 8	Size 9
Dimensions in inches (mm)									
Height	6.45 (163.8)	7.16 (181.9)	9.93 (252.2)	9.93 (252.2)	12.00 (304.8) ①	13.50 (342.9) ①	18.62 (472.9) ①	19.25 (489) ①	25.00 (635) ①
Width	3.31 (84.1)	3.31 (84.1)	4.62 (117.3)	4.62 (117.3)	7.00 (177.8) ①	7.00 (177.8) ①	23.50 (596.9) ①	23.50 (596.9) ①	32.00 (812.8) ①
Depth	4.61 (117.1)	4.96 (126)	6.75 (171.5)	6.75 (171.5)	7.75 (196.9) ①	8.75 (222.3) ①	11.00 (279.4) ①	11.00 (279.4) ①	13.00 (330.2) ①
Panel area—square inches	21.35	23.7	46.0	46.0	84.0	94.5	437.5	452.4	800
Weight—pounds	3.5	3.5	11.5	11.5	25	42	215	265	315
Cable connection	—	—	—	—	Front	Front	Front/rear	Front/rear	Front/rear
Maximum cable size/phase copper (AWG/MCM)	6 AWG	3 AWG	1/0	4/0	1–500 MCM	2–500 MCM	3–500 MCM	4–500 MCM	8–500 MCM
Auxiliary electrical circuits available	8	6	6	6	4	4	3	3	4
Latched version available	Yes	Yes	Yes	Yes	Yes	Yes	No	No	No

Mechanical interlock combinations available

Sizes	00, 0, 1, 2, 3, 4	5	6	7, 8	9
00, 0, 1, 2, 3, 4	Vert., Horiz.	Vert., Horiz.	Vert., Horiz.	Vert., Horiz.	Vert., Horiz.
5	—	—	—	—	—
6	—	—	—	—	—
7, 8	—	—	—	—	—
9	—	—	—	—	—

Data from Tables 430–147 Through 150 of 1996 NEC: Motor Amperes at Full Load ②, Three-Phase AC

hp	Single-Phase AC		Induction Type Squirrel Cage and Wound-Rotor Amperes					DC		hp	Single-Phase AC		Induction Type Squirrel Cage and Wound-Rotor Amperes					DC	
	115V	230V	200V	230V	460V	575V	120V	240V	115V		230V	200V	230V	460V	575V	120V	240V		
1/6	4.4	2.2	—	—	—	—	—	—	30	—	—	92	80	40	32	—	106		
1/4	5.8	2.9	—	—	—	—	3.1	1.6	40	—	—	120	104	52	41	—	140		
1/3	7.2	3.6	—	—	—	—	4.1	2.0	50	—	—	150	130	65	52	—	173		
1/2	9.8	4.9	2.5	2.2	1.1	0.9	5.4	2.7	60	—	—	177	154	77	62	—	206		
3/4	13.8	6.9	3.7	3.2	1.6	1.3	7.6	3.8	75	—	—	221	192	96	77	—	255		
1	16	8	4.8	4.2	2.1	1.7	9.5	4.7	100	—	—	285	248	124	99	—	341		
1-1/2	20	10	6.9	6.0	3.0	2.4	13.2	6.6	125	—	—	359	312	156	125	—	425		
2	24	12	7.8	6.8	3.4	2.7	17	8.5	150	—	—	414	360	180	144	—	506		
3	34	17	11.0	9.6	4.8	3.9	25	12.2	200	—	—	552	480	240	192	—	675		
5	56	28	17.5	15.2	7.6	6.1	40	20	250	—	—	—	—	302	242	—	—		
7-1/2	80	40	25.3	22	11	9	58	29	300	—	—	—	—	361	289	—	—		
10	100	50	32.2	28	14	11	76	38	350	—	—	—	—	414	336	—	—		
15	—	—	48.3	42	21	17	—	55	400	—	—	—	—	477	382	—	—		
20	—	—	62.1	54	27	22	—	72	450	—	—	—	—	515	412	—	—		
25	—	—	78.2	68	34	27	—	89	500	—	—	—	—	590	472	—	—		

Notes

- ① For Sizes 5–9 contactors only; for starter Sizes 5–9, refer to factory.
- ② These current values are for motors running at usual speeds and with normal torque characteristics. Motors for special low speed or high torque may require higher current. In all cases, heaters should be selected on basis of information on motor nameplate or motor card data.

Combination Ratings

Sizes 00–2

Short-Circuit Protective Device (SCPD)	Max. Rating SCPD	Circuit Breaker Interrupting Rating	Short-Circuit Withstand Capability	
			Current	Voltage
Sizes 00, 0, 1				
Class H fuse	60A	—	5000A	600V
Class J fuse	60A	—	100,000A	600V
Class R fuse	60A	—	100,000A	600V
Class T fuse	60A	—	100,000A	600V
Magnetic only ^① Type CB ^②	30A	Marked HMCP	100,000A 50,000A	480V 600V
Thermal/magnetic Type CB ^③	50A	65,000A	65,000A	480V
		25,000A	25,000A	600V
		100,000A	100,000A	480V
		35,000A	35,000A	600V
Magnetic only Type CB + CL ^④	30A	HMCP + current limiter	100,000A	600V
Thermal/magnetic Type CLB ^⑤	50A	150,000A	100,000A	480V
Size 2				
Class H fuse	100A	—	5000A	600V
Class J fuse	100A	—	100,000A	600V
Class R fuse	100A	—	100,000A	600V
Class T fuse	100A	—	100,000A	600V
Magnetic only ^① Type CB ^②	50A	Marked HMCP	100,000A 50,000A	480V 600V
Thermal/magnetic Type CB ^③	90A	65,000A	65,000A	480V
		25,000A	25,000A	600V
		100,000A	100,000A	480V
		35,000A	35,000A	600V
Magnetic only Type CB + CL ^④	50A	HMCP + current limiter	100,000A	600V
Thermal/magnetic Type CLB ^⑤	50A	150,000A	100,000A	480V

Coil Suffix

Other Available Coil Voltages—AC and DC Coils ^⑦

Coils	Catalog Number Suffix	Coil Rating (Volts/Hertz)	Catalog Number Suffix	Coil Rating (Volts/Hertz)
	B	200-208/60	P	48/60
	C	240/60 and 480/60	R	120/60 and 240/60
	D	440/50	U	440-480/50 or 60 Rect. to DC
	E	600/60 Hz	V	110/60
	G	220/50	W	240/60
	H	380/50	X	480/60
	I	24/60	Y	415/50
	J	110-120/50 or 60 Rect. to DC	Z	277/60
	K	220-240/50 or 60 Rect. to DC	—	—
DC ^{⑧⑨}	L	24 Vdc	S	125 Vdc
	M	48 Vdc	T	250 Vdc

Sizes 3 and 4

Short-Circuit Protective Device (SCPD)	Max. Rating SCPD	Circuit Breaker Interrupting Rating	Short-Circuit Withstand Capability	
			Current	Voltage
Size 3				
Class H fuse	60A	—	5000A	600V
Class J fuse	60A	—	100,000A	600V
Class R fuse	60A	—	100,000A	600V
Class T fuse	60A	—	100,000A	600V
Magnetic only ^① Type CB ^②	100A	Marked HMCP	100,000A 50,000A	480V 600V
Thermal/magnetic Type CB ^③	150A	65,000A	65,000A	480V
		25,000A	25,000A	600V
		100,000A	100,000A	480V
		35,000A	35,000A	600V
Magnetic only Type CB + CL ^④	100A	HMCP + current limiter	100,000A	600V
Thermal/magnetic Type CLB ^⑤	150A	50,000A	100,000A	480V
Size 4				
Class H fuse	400A	—	10,000A	600V
Class J fuse	400A	—	100,000A	600V
Class R fuse	400A	—	100,000A	600V
Class T fuse	400A	—	100,000A	600V
Magnetic only ^① Type CB ^②	150A	Marked HMCP	100,000A 50,000A	480V 600V
Thermal/magnetic Type CB ^③	250A	65,000A	65,000A	480V
		25,000A	25,000A	600V
		100,000A	100,000A	480V
		35,000A	35,000A	600V
Magnetic only Type CB + CL ^④	150A	HMCP + current limiter	100,000A	600V
Thermal/magnetic Type CB + CL ^⑤	250A	200,000A	100,000A	600V
Thermal/magnetic Type CLB ^⑥	250A	150,000A	100,000A	480V

Notes

- ① Instantaneous adjustable trip.
- ② Circuit breaker.
- ③ Inverse time circuit breaker.
- ④ Instantaneous adjustable trip with current limiting attachment.
- ⑤ Inverse time with built-in current limiting attachment.
- ⑥ Inverse time current limiting breaker.
- ⑦ Availability may be limited.
- ⑧ DC coils for Size 5 and 6 contactors and starters are intermittent duty rated only. A mechanical latch is required.
- ⑨ DC coils. Use only on contactors originally supplied with a DC coil.

33.2 NEMA Contactors and Starters

A200 Series

Dimensions

Approximate Dimensions in Inches (mm)

Not to be used for construction purposes unless approved.

33

Open Non-Reversing Starters

Figure A—Sizes 00–4

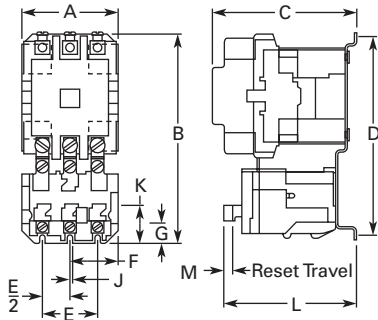

Figure B—Size 5

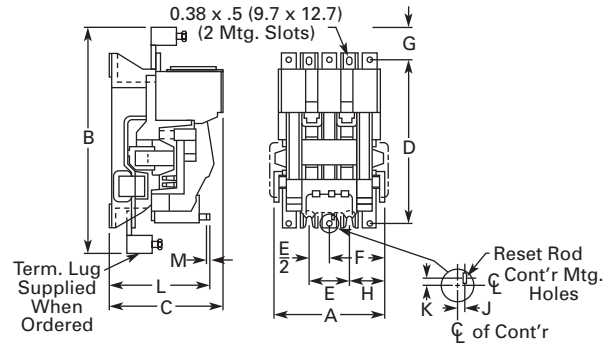
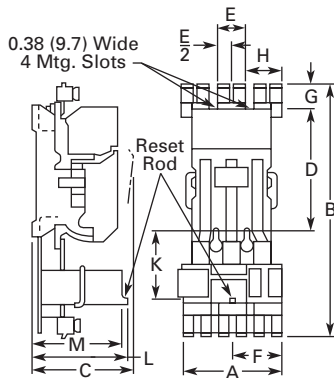

Figure C—Size 6



Dimensions and Shipping Weights

NEMA Size	No. of Poles	Fig.	Mounting Screws		A	B	C	D	E	F	G	H	J	K	L	M	Weight, Lbs (kg)
			No.	Size													
00, 0, 1	2, 3	A	3	#10	3.31 (84.1)	6.42 (163.1)	4.61 (117.1)	6.00 (152.4)	1.88 (47.8)	1.66 (42.2)	0.23 (5.8)	—	0.39 (9.9)	0.59 (15.0)	4.48 (113.8)	0.27 (6.9)	35.0 (15.9)
2	2, 3	A	3	#10	3.31 (84.1)	7.17 (182.1)	4.94 (125.5)	6.75 (171.5)	1.88 (47.8)	1.66 (42.2)	0.23 (5.8)	—	0.41 (10.4)	0.77 (19.6)	4.53 (115.1)	0.27 (6.9)	43.0 (19.5)
3, 4	2, 3	A	3	1/4 in.	4.63 (117.6)	9.94 (252.5)	6.75 (171.5)	9.25 (235.0)	2.88 (73.2)	.94 (23.9)	0.38 (9.7)	—	0.55 (14.0)	0.80 (20.3)	6.36 (161.5)	0.27 (6.9)	115.0 (52.2)
5	3	B	4	3/8 in.	7.59 (192.8)	16.22 (412.0)	7.75 (196.9)	11.00 (279.4)	2.75 (69.9)	3.81 (96.8)	2.69 (68.3)	2.42 (61.5)	0.33 (8.4)	0.33 (8.4)	7.00 (177.8)	0.27 (6.9)	29.0 (13.2)
6	3	C	4	3/8 in.	9.25 (235.0)	23.50 (596.9)	9.50 (241.3)	11.00 (279.4)	2.75 (69.9)	4.81 (122.2)	2.75 (69.9)	3.06 (77.7)	—	6.50 (165.1)	8.44 (214.4)	0.27 (6.9)	55.0 (25.0)
7	3	①	①	①	37.88 (962.2)	21.50 (546.1)	11.75 (298.5)	—	—	—	—	—	—	—	—	—	—
8	3	①	①	①	37.88 (962.2)	21.50 (546.1)	11.75 (298.5)	—	—	—	—	—	—	—	—	—	—
9	3	①	①	①	①	①	①	①	①	①	①	①	①	①	①	①	①

Note

① Refer to factory.

Approximate Dimensions in Inches (mm)

Not to be used for construction purposes unless approved.

Open Reversing Starters

Figure A—Sizes 00–4 Horizontal

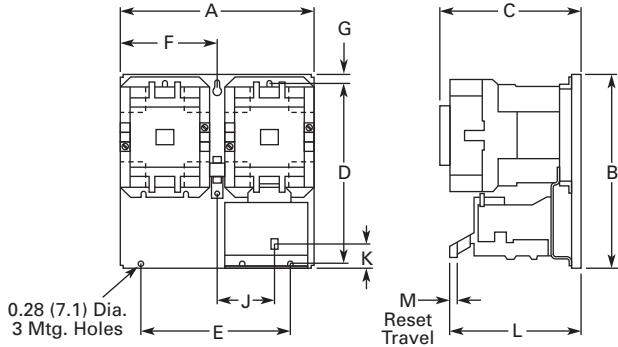
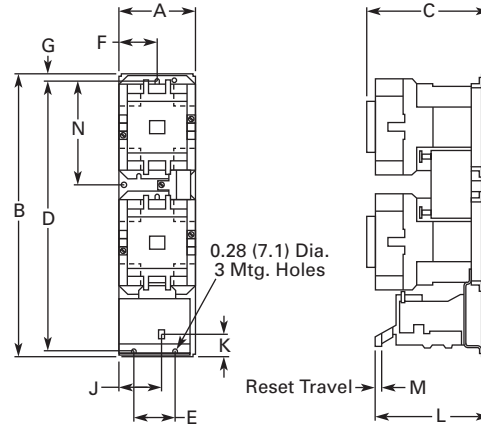

Figure B—Sizes 00–4 Vertical



Dimensions and Shipping Weights

NEMA Size	Number of Poles	Fig.	Mounting Screws		A	B	C	D	E	F	G	J	K	L	M	N	Weight, Lbs (kg)
			No.	Size													
00, 0, 1	3 x 3 Horiz.	A	3	#10	7.13 (181.1)	6.50 (165.1)	5.05 (128.3)	6.00 (152.4)	5.69 (144.5)	3.56 (90.4)	0.25 (6.4)	2.3 (58.4)	0.59 (15.0)	4.92 (125.0)	0.27 (6.9)	—	9.0 (4.0)
	3 x 3 Vert.	B	3	#10	3.33 (84.6)	11.63 (295.4)	5.05 (128.3)	11.13 (282.7)	1.88 (47.8)	1.66 (42.2)	0.25 (6.4)	0.39 (9.9)	0.59 (15.0)	4.92 (125.0)	0.27 (6.9)	4.52 (114.8)	9.8 (4.4)
2	3 x 3 Horiz.	A	3	#10	7.13 (181.1)	7.25 (184.2)	5.38 (136.7)	6.75 (171.5)	5.69 (144.5)	3.56 (90.4)	0.25 (6.4)	2.31 (58.7)	0.77 (19.6)	4.97 (126.2)	0.27 (6.9)	—	10.8 (4.9)
	3 x 3 Vert.	B	3	#10	3.33 (84.6)	12.38 (314.5)	5.38 (136.7)	11.88 (301.8)	1.88 (47.8)	1.66 (42.2)	0.25 (6.4)	0.39 (9.9)	0.77 (19.6)	4.97 (126.2)	0.27 (6.9)	4.52 (114.8)	12.2 (5.5)
3, 4	3 x 3 Horiz.	A	3	1/4 in.	9.75 (247.7)	10.13 (257.3)	7.25 (184.2)	9.25 (235.0)	8.00 (203.2)	4.88 (124.0)	0.44 (11.2)	3.11 (79.0)	0.80 (20.3)	6.86 (174.2)	0.27 (6.9)	—	26.0 (11.8)
	3 x 3 Vert.	B	3	1/4 in.	4.63 (117.6)	19.81 (503.2)	7.25 (184.2)	18.94 (481.1)	2.88 (73.2)	2.94 (74.7)	0.44 (11.2)	0.55 (14.0)	0.80 (20.3)	6.86 (174.2)	0.27 (6.9)	7.91 (200.9)	28.0 (12.7)
5	3 x 3 Horiz.	—	4	3/8 in.	35.25 (895.4)	25.50 (647.7)	8.75 (222.3)	—	—	—	—	—	—	—	—	—	73.0 (33.1)
6	3 x 3 Horiz.	—	4	3/8 in.	35.25 (895.4)	25.50 (647.7)	10.50 (266.7)	—	—	—	—	—	—	—	—	—	127.0 (57.7)
7	①	①	①	①	①	①	①	①	①	①	①	①	①	①	①	①	①
8	①	①	①	①	①	①	①	①	①	①	①	①	①	①	①	①	①
9	①	①	①	①	①	①	①	①	①	①	①	①	①	①	①	①	①

Note

① Refer to factory.

33.2 NEMA Contactors and Starters

A200 Series

Approximate Dimensions in Inches (mm)

Not to be used for construction purposes unless approved.

Open Multi-Speed Starters

33

Figure A—Sizes 00–4

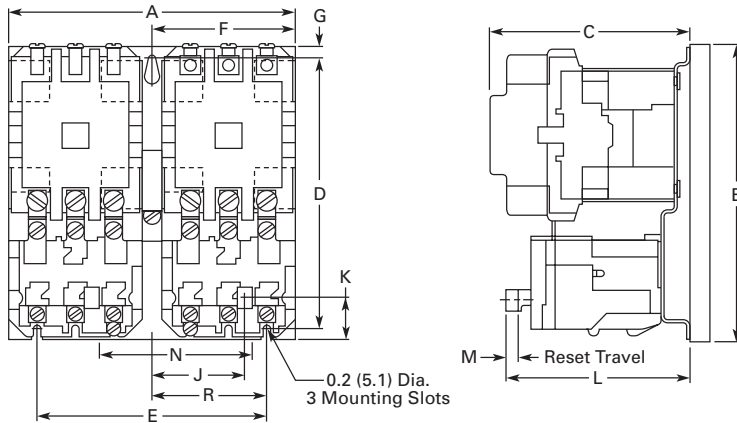
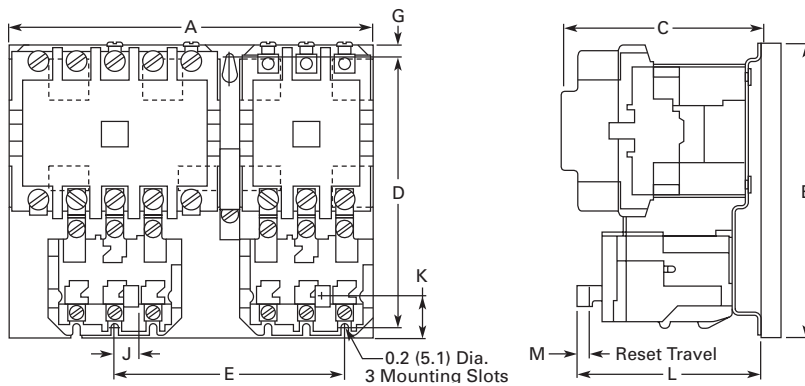

Figure B—Sizes 2



Dimensions and Shipping Weights

NEMA Size	Number of Poles	Fig.	Mounting Screws		A	B	C	D	E	F	G	J	K	L	M	N	P	R	Weight, Lbs (kg)	
			No.	Size																
00, 0, 1	3 x 3 Horiz.	A	3	#10	7.13 (181.1)	6.50 (165.1)	5.05 (128.3)	6.00 (152.4)	5.69 (144.5)	3.56 (90.4)	0.25 (6.4)	2.30 (58.4)	0.33 (8.4)	4.92 (125.0)	0.27 (6.9)	3.81 (96.8)	—	2.91 (73.9)	10.0 (4.5)	
	5 x 3 Horiz.	B	3	#10	8.00 (203.2)	6.50 (165.1)	5.05 (128.3)	6.00 (152.4)	6.53 (165.9)	3.56 (90.4)	0.25 (6.4)	2.30 (58.4)	0.48 (12.2)	4.92 (125.0)	0.27 (6.9)	4.66 (118.4)	—	2.91 (73.9)	11.0 (5.0)	
2	3 x 3 Horiz.	A	3	#10	7.13 (181.1)	7.25 (184.2)	5.38 (136.7)	6.75 (171.5)	5.69 (144.5)	3.56 (90.4)	0.25 (6.4)	2.69 (68.3)	0.69 (17.5)	4.97 (126.2)	0.27 (6.9)	3.81 (96.8)	—	2.91 (73.9)	11.0 (5.0)	
	5 x 3 Horiz.	B	3	#10	8.88 (225.6)	7.25 (184.2)	5.38 (136.7)	6.75 (171.5)	6.56 (166.6)	3.56 (90.4)	0.25 (6.4)	2.69 (68.3)	0.69 (17.5)	4.97 (126.2)	0.27 (6.9)	4.66 (118.4)	—	2.84 (72.1)	13.0 (5.9)	
3, 4	3 x 3 Horiz.	A	3	1/4 in.	9.75 (247.7)	10.13 (257.3)	7.25 (184.2)	9.25 (235.0)	8.00 (203.2)	4.88 (124.0)	0.44 (11.2)	3.11 (79.0)	0.80 (20.3)	6.86 (174.2)	0.27 (6.9)	5.13 (130.3)	—	4.00 (101.6)	28.0 (12.7)	
	5 x 3 Horiz.	B	3	1/4 in.	12.38 (314.5)	10.13 (257.3)	7.25 (184.2)	9.25 (235.0)	9.31 (236.5)	4.88 (124.0)	0.44 (11.2)	3.11 (79.0)	0.80 (20.3)	6.86 (174.2)	0.27 (6.9)	6.44 (163.6)	—	4.00 (101.6)	33.5 (15.2)	
5	⓪	⓪	⓪	⓪	⓪	⓪	⓪	⓪	⓪	⓪	⓪	⓪	⓪	⓪	⓪	⓪	⓪	⓪	⓪	⓪
6	⓪	⓪	⓪	⓪	⓪	⓪	⓪	⓪	⓪	⓪	⓪	⓪	⓪	⓪	⓪	⓪	⓪	⓪	⓪	⓪

Notes

Three-pole x three-pole devices are for Wye-Wye two-winding motors only.

⓪ Refer to factory.

Relays—Thermal and Fast Trip

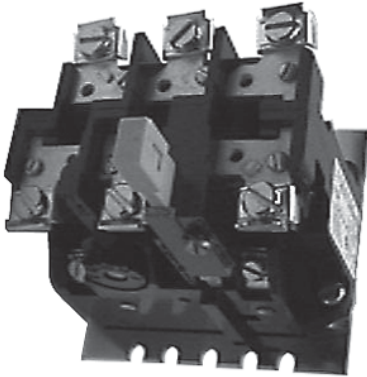

Contents

<i>Description</i>	<i>Page</i>
Contactors—Non-Reversing and Reversing	64
Starters—Non-Reversing and Reversing	70
Relays—Thermal and Fast Trip	
Standards and Certifications	92
Instruction Leaflets	92
Thermal Type B, Class 20, Manual Reset	93
Thermal Type A, Class 20, Auto/Manual Reset	96
Type FT Fast Trip, Class 10	99
Heater Selection	102
Relays—Current Sensing Protective	104

Relays—Thermal and Fast Trip

Product Overview

Type B and Type A, Class 20 Thermal Overload Relays from Eaton’s electrical sector will protect the motor against abnormal overload conditions. Bimetallic actuated, they are available as either ambient compensated or non-compensated in either single-pole or block type three-pole design. Type B use one pole of the three-pole block for single-phase.

Single-pole relays are also available as Fast Trip Class 10 ambient compensated type, which provides approximately 125% motor protection with a tripping time of less than 10 seconds, at 600% of heater current rating.

Fast trip relays can be identified by the green reset rods. They are available for panel or starter mounting. The three-pole fast trip design is composed of three single-pole relays on a common baseplate, with a common reset bar.

The bimetal element is actuated by precisely calibrated heater elements which are connected directly in the circuit to be protected. Thermal actuation of this device opens the contacts in the coil circuit of a contactor or relay which results in the disconnection of power to the overloaded circuit.

Interchangeable thermal heater elements for single-pole standard trip and block type overload relays are available to cover motor full load currents from 0.29 to 133A in approximately 10% steps (see Heater Application Table). Fast trip overload relays do not have interchangeable heater elements but are available in a series of ratings to cover motor full load currents from 1.6 to 150A in approximately 50% steps.

Features

Manual or Automatic Reset

Type B is furnished with a manual reset. Type A is normally furnished set for manual reset operation and may be quickly adjusted for automatic reset when required. Automatic reset should not be used with two-wire control or where automatic restarting would endanger either personnel or equipment.

Trip Indication

An immediate visible indication of trip is provided on the overload relay. When an overload occurs, which causes the relay to operate, a trip indicator projects out and thus shows positive visual indication of trip. Type B has a mechanical trip bar to manually check the NC contact operation on the overload relay.

Adjustable Trip

On Type A, the trip rating of a specific heater element can be adjusted over a range of approximately 85% to 115% of its respective rating to permit the desired close protection.

This is accomplished by turning the adjusting knob on the relay to the respective stop position.

Positive Contact Break

A follow-through contact, provided on the stationary terminal of the snap action control switch, provides reliable electrical continuity during toggling, thus eliminating false trip sometimes prevalent with thermally operated switches. This contact also allows contact wipe for further reliability.

33.2 NEMA Contactors and Starters

A200 Series

33

Ambient Compensation

Motor overload protection can be provided with the same trip characteristics in ambient temperature from -40° to 77°C (-40° to 167°F). A compensating bimetal maintains a constant "travel to trip" distance independent of ambient conditions. The compensating feature is fully automatic and no adjustments are required over wide fluctuations in ambient temperatures. Compensated relays are identified by black reset rods on Type A and light gray reset rods on Type B, while non-compensated relays use red reset rods. AA three-pole units have gray reset rods. AA one-pole units have black reset rods.

Control Contact

Single-pole and block type relays are supplied as standard with a SPST NC control contact. A SPDT NO-NC with common is available as a factory modification on Type A. An isolated NO contact can be supplied on Type B as either a factory modification or as a field kit.

Standards and Certifications

- UL 508
- CSA
- ANSI/NEMA ICS 2-222



Instruction Leaflets

- 14885B Fast Trip A
Sizes 0–4, 3-Pole
OL Relay
- 14567E Type A Sizes 1–2,
1-Pole OL Relay
Mod A
- 14568 Type A Sizes 1–2,
3-Pole OL Relay
Mod J
- 14570D Type A Sizes 3–4,
3-Pole OL Relay
Mod J
- 14569C Type A Sizes 3–4,
1-Pole OL Relay
Mod A
- 17093A Type B OLR for
Sizes 7, 8 and
9 Contactors
- 16955A Type B Sizes 1–2,
1-Pole OL Relay
- 16954A Type B Sizes 1–2,
3-Pole OL Relay
- 15392B Type B Sizes 3–4,
3-Pole OL Relay
- 13676F Fast Trip Sizes 0–4,
1-Pole OL Relay

Thermal Type B, Class 20, Manual Reset

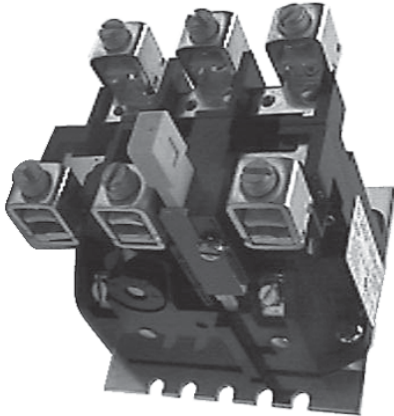

Contents

<i>Description</i>	<i>Page</i>
Contactors—Non-Reversing and Reversing	64
Starters—Non-Reversing and Reversing	70
Relays—Thermal and Fast Trip	91
Thermal Type B, Class 20, Manual Reset	
Product Selection	94
Accessories	94
Technical Data	95
Dimensions	95
Thermal Type A, Class 20, Auto/Manual Reset	96
Type FT Fast Trip, Class 10	99
Heater Selection	102
Relays—Current Sensing Protective	104

Thermal Type B, Class 20, Manual Reset

Application Description

The Type B overload relay is designed to protect industrial motors against overload conditions. Using modern block type, bimetallic design, this relay will provide Class 20 operation in either single-phase or three-phase applications.

Operation

The Type B overload relay is a bimetallic actuated device. The bimetal elements are operated by precisely calibrated heaters. The heater elements are connected either directly in the circuit to be measured, or through current transformers on applications NEMA Size 5 and larger.

As the bimetals are heated by motor current flow, a deflection force is produced. Upon a sustained level of abnormal current flow, the deflection becomes great enough to open the snap-action output contact.

Ambient Compensation

The Type B ambient compensated design is supplied as standard on all A200 starters. This design uses a second compensating bimetal responsive to ambient air temperature in the surrounding enclosure. This feature reduces nuisance tripping in applications using compact control panels and motor control centers where internal temperature rise is significant compared to motor ambient temperature. The compensating characteristic is maintained in ambient temperatures from 40° to 77°C.

Features

- Ambient compensation standard
- Alarm contact field mountable
- Class 20—600V design
- Inverse time delay trip
- Test trip device for weld check
- Hi-visibility up-front trip indication
- Trip-free reset mechanism

Product Selection

Heaters

Enter heaters as separate item by listing catalog number from tables, **Pages 102 and 103**, as required per starter.

Relays

Type B Overload Relay
Panel Mounting



Thermal Type B Overload Relay

Motor Full Load Amps	Panel Mounted		Starter Mounted Replacement for Type B Overload Relays		Replacement for Type A Overload Relays in Manual Reset Mode (Three-Pole Only) ①	
	Ambient Comp. Catalog Number	Non-Comp. Catalog Number	Ambient Comp. Catalog Number	Non-Comp. Catalog Number	Ambient Comp. Catalog Number	Non-Comp. Catalog Number
Single-Pole (One NC Contact)						
0.25–26.2	BA11JP	BN11JP	BA11A	BN11A	—	—
26.3–45	BA21JP	BN21JP	BA21A	BN21A	—	—
19–90	Use three-pole design, wire three poles in series	Use three-pole design, wire three poles in series	Use three-pole design, wire three poles in series	Use three-pole design, wire three poles in series	Use three-pole design, wire three poles in series	Use three-pole design, wire three poles in series
19–135	Use three-pole design, wire three poles in series	Use three-pole design, wire three poles in series	Use three-pole design, wire three poles in series	Use three-pole design, wire three poles in series	Use three-pole design, wire three poles in series	Use three-pole design, wire three poles in series
Three-Pole (One NC Contact)						
0.25–26.2	BA13JP	BN13JP	BA13A ②	BN13A ②	BA13J	BN13J
26.3–45	BA23JP	BN23JP	BA23A	BN23A	BA23J	BN23J
19–90	BA33P	BN33P	BA33A	BN33A	BA33A	BN33A
19–135	BA43P	BN43P	BA43A	BN43A	BA43A	BN43A

Accessories

Alarm Contact Kit Selection ①

Type B Overload Relay Size	Catalog Number
1, 2	B3N0-2
3, 4	B3N0-4

Notes

- ① Includes contactor mounting bracket, overload relay and connection straps to contactor.
- ② For replacement on B200 size 00, 0, 1 use BA23A instead of BA13A and use BN23A instead of BN13A.

Technical Data

Control Contact Ratings—NEMA B600 NO and NC Control Contact Rating

AC Volts	Make	Break
24–120	30A	3A
120–600	3600 VA	360 VA

Dimensions

Approximate Dimensions in Inches (mm)

Not to be used for construction purposes unless approved.

Thermal Type B Overload Relays

Sizes 1 and 2—Three-Pole, Panel Mounted

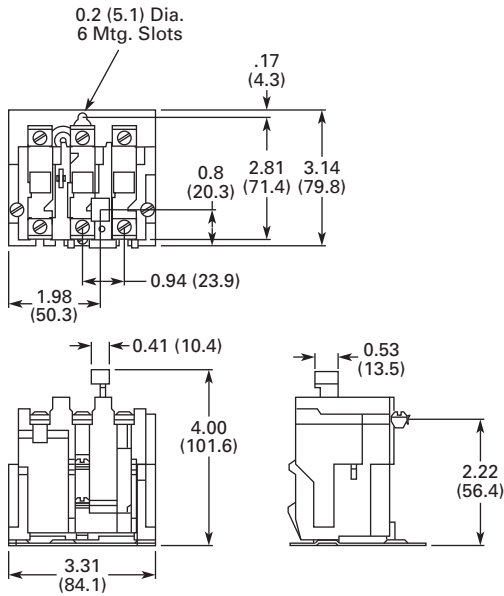

Sizes 3 and 4—Three-Pole, Panel Mounted

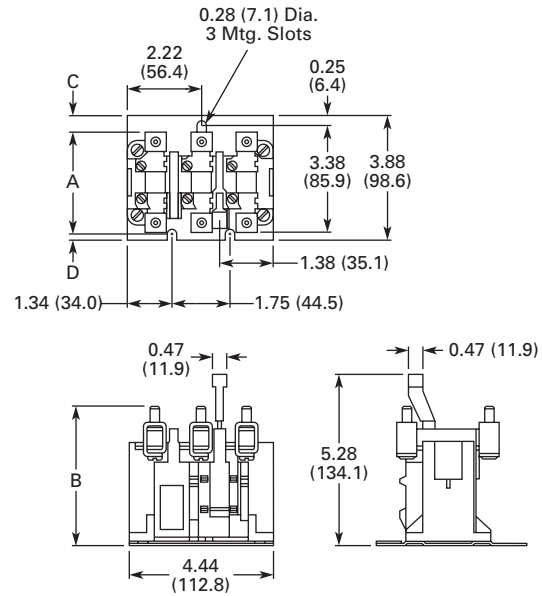

Dimensions

Relay Size	A	B	C	D
3	3.13 (79.5)	4.06 (103.1)	0.44 (11.2)	0.31 (7.9)
4	3.38 (85.9)	4.38 (111.3)	0.31 (7.9)	0.19 (4.8)

Note

① Alarm contact available as factory modification of field mountable. For factory modification, add suffix B.

Thermal Type A, Class 20, Auto/Manual Reset



33

Contents

<i>Description</i>	<i>Page</i>
Contactors—Non-Reversing and Reversing	64
Starters—Non-Reversing and Reversing	70
Relays—Thermal and Fast Trip.	91
Thermal Type B, Class 20, Manual Reset	93
Thermal Type A, Class 20, Auto/Manual Reset	
Product Selection	97
Technical Data and Specifications.	97
Dimensions	98
Type FT Fast Trip, Class 10.	99
Heater Selection.	102
Relays—Current Sensing Protective	104

Thermal Type A, Class 20, Auto/Manual Reset

Application Description

The Type A overload relay is designed to protect industrial motors against overload conditions. Using modern block type, bimetallic design, this relay will provide Class 20 operation in either single- or three-phase applications.

Features

- Field selectable manual/ auto reset
- Alarm contact factory available
- Class 20—600V design
- Inverse time delay trip
- Adjustable trip rating $\pm 15\%$
- Color coded reset rod:
 - Compensated (gray)
 - Non-compensated (red)

Operation

The Type A overload relay is a bimetallic actuated device. The bimetal elements are operated by precisely calibrated heaters. The heater elements are connected either directly in the circuit to be measured, or through current transformers on applications NEMA Size 5 and larger.

As the bimetals are heated by motor current flow, a deflection force is produced. Upon a sustained level of abnormal current flow, the deflection becomes great enough to open the snap-action output contact.

Automatic Reset

The Type A overload relay can be supplied as an option on all A200 starters to provide automatic reset operation. The overload relay is always shipped in the non-automatic mode. To set up auto operation, reposition the reset rod by loosening and re-tightening a hold-down clamp at the base of overload relay.

Product Selection

Heaters

Enter heaters as separate item by listing catalog number from tables, **Pages 102 and 103**, as required per starter.

Relays

**Type A Overload Relay
Single-Pole Panel
Mounting**



Thermal Type A Overload Relay ①

Motor Full Load Amps	Panel Mounted		Starter Replacement	
	Ambient Comp. Catalog Number	Non-Comp. Catalog Number	Ambient Comp. Catalog Number	Non-Comp. Catalog Number
Single-Pole (One NC Contact)				
0.25–26.2	AA11P	AN11P	AA11A	AN11A
26.3–45	AA21P	AN21P	AA21A	AN21A
19–90	AA31P	AN31P	AA31A	AN31A
19–135	AA41P	AN41P	AA41A	AN41A
Three-Pole (One NC Contact)				
0.25–26.2	AA13P ②	AN13P ②	AA13A ②	AN13A ②
26.3–45	AA23P ②	AN23P ②	AA23A ②	AN23A ②
19–90	AA33P ②	AN33P ②	AA33A ②	AN33A ②
19–135	AA43P ②	AN43P ②	AA43A ②	AN43A ②

Technical Data and Specifications

Control Contact Ratings

AC Volts	Normally Closed		Normally Open	
	Make	Break	Make	Break
Three-Pole Control Contact Ratings				
24–120	20A	2A	0.5A	0.5A
120–600	2400 VA	240 VA	600 VA	60 VA
Single-Pole Control Contact Ratings				
24–120	30A	3A	10A	1A
120–600	3600 VA	360 VA	1200 VA	120 VA

Notes

- ① For alarm contact (Form C), add Suffix **B**. Available only as factory modification on Type A relay.
- ② Three-pole Type B overload relay is a suitable alternative to a three-pole Type A overload relay in manual reset mode. For example, BA13JP for AA13P, BN23J for AN23A, etc. (See **Page 94**.)

33.2

NEMA Contactors and Starters

A200 Series

Dimensions

Approximate Dimensions in Inches (mm)

Not to be used for construction purposes unless approved.

33

Type A

Single-Pole (Sizes 4 Shown)

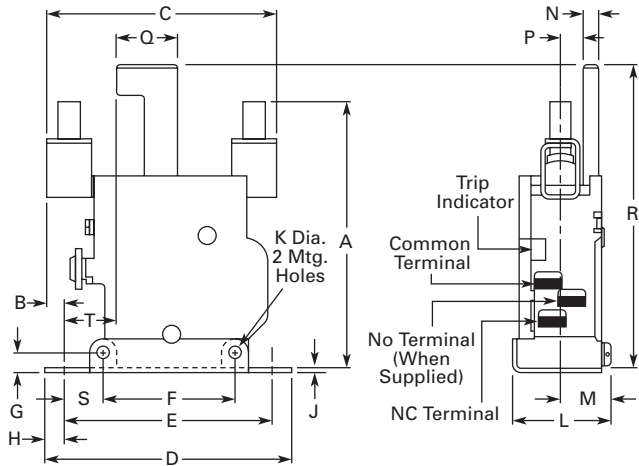

Three-Pole (Size 4 Shown)

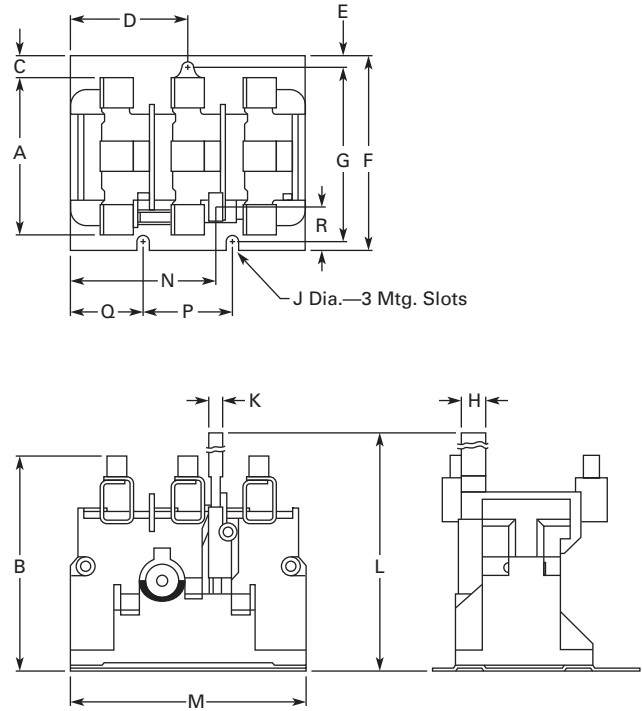

Dimensions

Dimension	Relay Size			
	1	2	3	4
A	2.72 (69.1)	3.48 (88.4)	4.19 (106.4)	4.5 (114.3)
B	0.94 (23.9)	0.67 (17.0)	0.25 (6.4)	0.38 (9.7)
C	2.75 (69.9)	3.5 (88.9)	3.53 (89.7)	3.78 (96.0)
D	3.25 (82.6)	3.25 (82.6)	4.13 (104.9)	4.13 (104.9)
E	2.63 (66.8)	2.63 (66.8)	3.38 (85.9)	3.38 (85.9)
F	1.34 (34.0)	1.34 (34.0)	2.19 (55.6)	2.19 (55.6)
G	0.25 (6.4)	0.25 (6.4)	0.28 (7.1)	0.28 (7.1)
H	0.31 (7.9)	0.31 (7.9)	0.38 (9.7)	0.38 (9.7)
J	0.06 (1.5)	0.06 (1.5)	0.06 (1.5)	0.06 (1.5)
K	0.22 (5.6)	0.22 (5.6)	0.27 (6.8)	0.27 (6.8)
L	1.34 (34.0)	1.34 (34.0)	1.69 (42.9)	1.69 (42.9)
M	0.66 (16.8)	0.66 (16.8)	0.88 (22.4)	0.88 (22.4)
N	0.16 (4.1)	0.16 (4.1)	0.27 (6.8)	0.27 (6.8)
P	0.22 (5.6)	0.22 (5.6)	0.34 (8.6)	0.34 (8.6)
Q	0.06 (1.5)	0.06 (1.5)	0.69 (17.5)	0.69 (17.5)
R	4.00 (101.6)	4.00 (101.6)	5.19 (131.8)	5.19 (131.8)
S	0.47 (11.9)	0.47 (11.9)	0.59 (15.0)	0.59 (15.0)
T	1.11 (28.2)	1.11 (28.2)	0.69 (17.5)	0.69 (17.5)

Dimensions

Dimension	Relay Size			
	1	2	3	4
A	2.38 (60.5)	2.44 (62.0)	3.13 (79.5)	3.38 (85.9)
B	3.13 (79.5)	3.17 (80.5)	4.06 (103.1)	4.38 (111.3)
C	0.36 (9.1)	0.33 (8.4)	0.44 (11.2)	0.31 (7.9)
D	1.66 (42.2)	1.66 (42.2)	2.22 (56.4)	2.22 (56.4)
E	0.17 (4.3)	0.17 (4.3)	0.25 (6.4)	0.25 (6.4)
F	2.81 (71.4)	2.81 (71.4)	3.38 (85.9)	3.38 (85.9)
G	3.08 (78.2)	3.08 (78.2)	3.88 (98.6)	3.88 (98.6)
H	0.47 (11.9)	0.47 (11.9)	0.47 (11.9)	0.47 (11.9)
J	0.20 (5.1)	0.20 (5.1)	0.28 (7.1)	0.28 (7.1)
K	0.28 (7.1)	0.28 (7.1)	0.47 (11.9)	0.47 (11.9)
L	4.00 (101.6)	4.00 (101.6)	5.28 (134.1)	5.28 (134.1)
M	3.31 (84.1)	3.31 (84.1)	4.44 (112.8)	4.44 (112.8)
N	1.80 (45.7)	1.80 (45.7)	2.77 (70.4)	2.77 (70.4)
P	1.89 (48.0)	1.89 (48.0)	1.75 (44.5)	1.75 (44.5)
Q	1.00 (25.4)	1.00 (25.4)	1.34 (34.0)	1.34 (34.0)
R	—	—	1.03 (26.2)	1.03 (26.2)

Type FT Fast Trip, Class 10

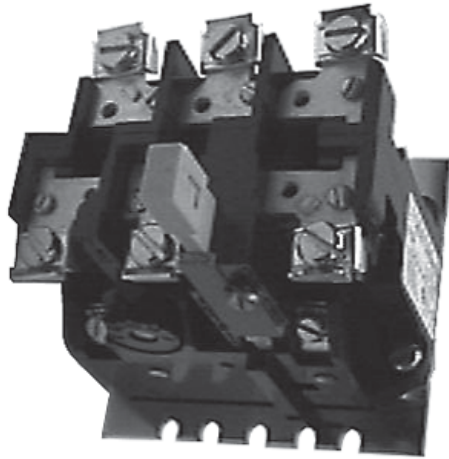

Contents

<i>Description</i>	<i>Page</i>
Contactors—Non-Reversing and Reversing	64
Starters—Non-Reversing and Reversing	70
Relays—Thermal and Fast Trip	91
Thermal Type B, Class 20, Manual Reset	93
Thermal Type A, Class 20, Auto/Manual Reset	96
Type FT Fast Trip, Class 10	
Product Selection	100
Technical Data and Specifications	100
Dimensions	101
Heater Selection	102
Relays—Current Sensing Protective	104

Type FT Fast Trip, Class 10

Application Description

The Type FT overload relay is designed to protect special purpose motors having restricted thermal and locked rotor capabilities. Using modern block type, bimetallic design, this relay will provide Class 10 operation in single- or three-phase applications.

Operation

The Type FT overload relay is a bimetallic actuated device. The bimetal elements are operated directly from line current, thus separate calibrating heater elements are not utilized. The overload relay may be wired directly in the motor circuit, or through-current transformers on applications larger than 150A.

As the bimetals are heated by motor current flow, a deflection force is produced. Upon a sustained level of abnormal current flow, the deflection becomes great enough to open the snap action output contact.

Features

- Class 10—600V design
- Inverse time delay trip
- Color coded reset rod—green
- Alarm contact factory available
- Field selectable manual/auto reset
- Adjustable trip rating ±20%
- Ambient compensation included

33.2

NEMA Contactors and Starters

A200 Series

Product Selection

Type FT Single-Pole

Type FT Single-Pole (One NC Contact); Three-Phase (Three NC Contacts in Series) ①

33

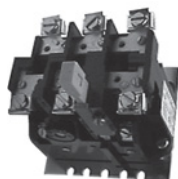

Motor Full Load Amperes	Panel Mounted		Starter Replacement	
	Single-Pole Catalog Number	Three-Pole Catalog Number	NEMA Size	Single-Pole Catalog Number
0.76–1.1	FT11P-1.1	FT13P-1.1	—	FT11A-1.1
1.1–1.6	FT11P-1.6	FT13P-1.6	—	FT11A-1.6
1.6–2.4	FT11P-2.4	FT13P-2.4	0, 1	FT11A-2.4
2.4–3.6	FT11P-3.6	FT13P-3.6	0, 1	FT11A-3.6
3.6–5.4	FT11P-5.4	FT13P-5.4	0, 1	FT11A-5.4
5.4–8.0	FT11P-8.0	FT13P-8	0, 1	FT11A-8
8.0–12	FT11P-12	FT13P-12	0, 1	FT11A-12
12–18	FT11P-18	FT13P-18	1	FT11A-18
16–24	—	FT13P-24	—	—
22–32	FT11P-32	FT13P-32	0, 1	FT11A-32
24–36	FT21P-36	FT23P-36	2	FT21A-36
36–54	FT21P-54	FT23P-54	12	FT21A-54
22–32	FT31P-32	FT33P-32	3	FT31A-32
32–48	FT31P-48	FT33P-48	3	FT31A-48
48–72	FT31P-72	FT33P-72	3	FT31A-72
72–110	FT41P-110	FT43P-110	4	FT41A-110
100–150	FT41P-150	FT43P-150	4	FT41A-150

Technical Data and Specifications

Control Contact Ratings

AC Volts	Normally Closed		Normally Open	
	Make	Break	Make	Break
24–120	30A	3A	10A	1A
120–600	3600 VA	360 VA	1200 VA	120 VA

Note

① Single-pole (1NO-NC contact): add suffix **B**. Three-pole (3NO-NC contacts): add suffix **B**. Example: FT13P**B**-12.

Dimensions

Approximate Dimensions in Inches (mm)

Not to be used for construction purposes unless approved.

Type FT Overload Relays

Three-Pole, Size 1

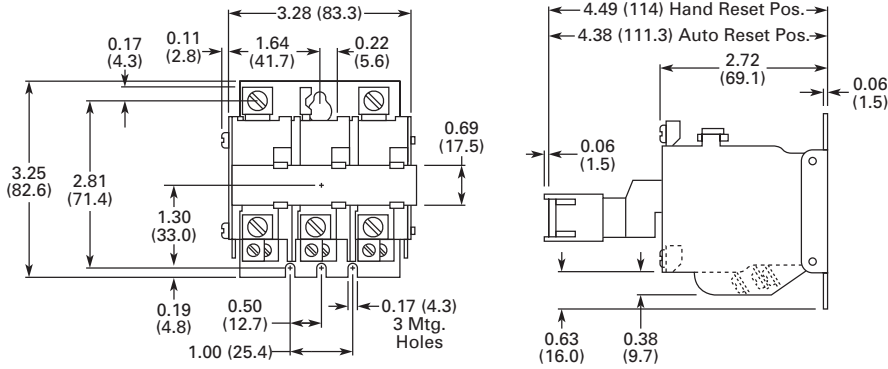

Three-Pole, Size 2

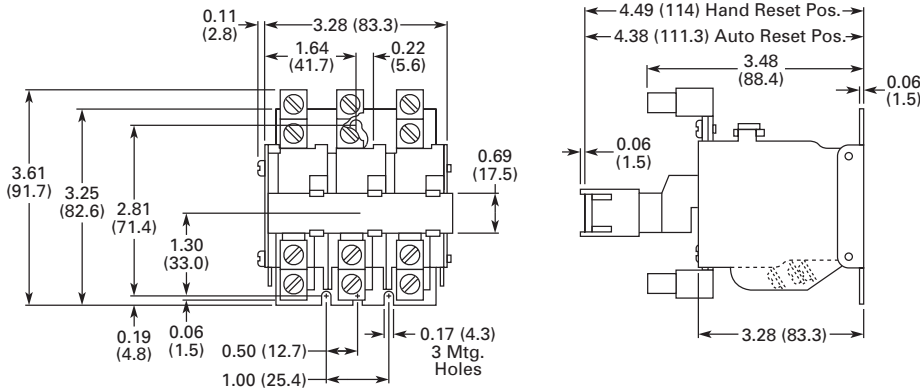

Three-Pole, Sizes 3, 4

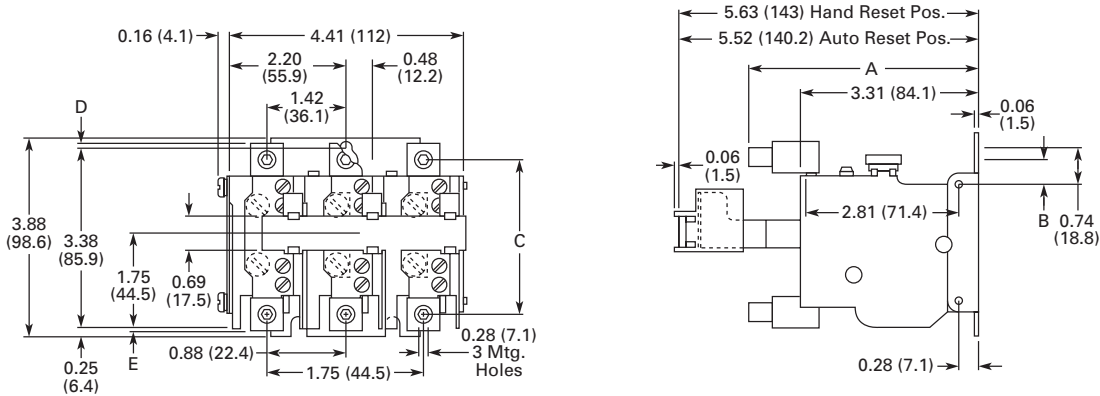

Dimensions

Relay Size	A	B	C	D	E
3	4.25 (108.0)	0.53 (13.5)	2.91 (73.9)	0.09 (2.3)	0.06 (1.5)
4	4.50 (114.3)	0.59 (15.0)	3.03 (77.0)	0.22 (5.6)	0.19 (4.8)

Heater Selection

General Information on Heater Coil Selection

For maximum motor protection and compliance with Article 430-32 of the National Electrical Code, select heater coils from the tables in this section on the basis of motor nameplate full load current.

When the full load current is unknown, selection may be made on the basis of average full load currents as shown on **Pages 118 and 119.**

Caution—The average ratings could be high or low for a specific motor and

therefore selection on this basis always involves risk. For fully reliable motor protection, select heater coils on the basis of full load current rating as shown on the motor nameplate.

Heater coils are rated to protect 40°C rise motors, and open and drip-proof motors having a **service factor of 1.15** where the motor and the controller are at the same ambient temperature.

For other conditions:

- For 50°C, 55°C, 75°C rise motors and **enclosed motors having a service factor of 1.0, select one size smaller coil.**
- Ambient temperature of controller lower than motor by 26°C (47°F), use one size smaller coil.
- Ambient temperature of controller higher than motor by 26°C (47°F), use one size larger coil.

Ultimate tripping current of heater coils is approximately 1.25 times the minimum current rating listed in the tables.

Type A and B Overload Relays, Sizes 3 and 4

Size Starter	Ambient Compensated Enclosed Starters	Non-Compensating Enclosed Starters	Heater (One Heater per Catalog Number) Catalog Number
	All Applications Full Load Current of Motor Amps		
For Size 4 Starters	12.8–14.1	11.9–13.0	FH68
	14.2–15.5	13.1–14.3	FH69
	15.6–17.1	14.4–15.9	FH70
	17.2–18.9	16.0–17.4	FH71
	19.0–20.8	17.5–19.1	FH72
	20.9–22.9	19.2–21.1	FH73
	23.0–25.2	21.2–23.2	FH74
	25.3–27.8	23.3–25.6	FH75
	27.9–30.6	25.7–28.1	FH76
	30.7–33.5	28.2–30.8	FH77
	33.6–37.5	30.9–34.5	FH78
	37.6–41.5	34.6–38.2	FH79
	41.6–56.3	38.3–42.6	FH80
	46.4–50	42.7–46	FH81
	51–55	47–51	FH82
	56–61	52–56	FH83
	62–66	57–61	FH84
	67–73	62–67	FH85
	74–78	68–72	FH86
	79–84	73–77	FH87
85–92	78–84	FH88	
For Size 3 Starters	93–101	85–91	FH89
	102–110	92–99	FH90
	111–122	100–110	FH91
	123–129	111–122	FH92
	130–133	123–128	FH93
	—	129–133	FH94

Type A and B Overload Relays, Sizes 5 and 6 ①

Compensated Overload Relay		Heater (One Heater per Catalog Number) Catalog Number
Open Starter Full Load Current of Motor (Amps)	Enclosed Starter	
Size 5 (with 300/5 Current Transformers)		
—	—	FH23
118–129	118–129	FH24
130–141	130–141	FH25
142–155	142–155	FH26
156–170	156–170	FH27
171–187	171–187	FH28
188–205	188–205	FH29
206–224	206–224	FH30
225–244	225–244	FH31
245–263	245–263	FH32
264–292	264–292	FH33
293–300	—	FH34
Size 6 (with 600/5 Current Transformers)		
—	—	FH23
236–259	236–259	FH24
260–283	260–283	FH25
284–310	284–310	FH26
311–340	311–340	FH27
341–374	341–374	FH28
375–411	375–411	FH29
412–448	412–448	FH30
449–489	449–489	FH31
490–527	490–527	FH32
528–585	528–540	FH33
586–600	—	FH34

Note

① Size 7 and larger—advise full load current.

Type A and B Overload Relays, Sizes 0, 1 and 2

Size Starter	Non-Compensated Open Starters and Ambient Comp. Open and Enclosed Starters		Heater (One Heater per Catalog Number) Catalog Number	Non-Compensating Enclosed Starters		Heater Catalog Number
	Block Type Overload sing Three Heaters	Single-Pole Type Overload		Block Type Overload Using Three Heaters	Single-Pole Type Overload	
Full Load Current of Motor (Amps)						
↑ For Size 2 Starters ↑ For Size 1 Starters ↑ For Size 0 Starters	0.25–0.27	0.29–0.31	FH03	0.24–0.25	0.28–0.30	FH03
	0.28–0.31	0.32–0.35	FH04	0.26–0.28	0.31–0.34	FH04
	0.32–0.34	0.36–0.39	FH05	0.29–0.31	0.35–0.37	FH05
	0.35–0.38	0.40–0.43	FH06	0.32–0.35	0.38–0.42	FH06
	0.39–0.42	0.44–0.48	FH07	0.36–0.39	0.43–0.47	FH07
	0.43–0.46	0.49–0.53	FH08	0.40–0.43	0.48–0.52	FH08
	0.47–0.50	0.54–0.58	FH09	0.44–0.47	0.53–0.56	FH09
	0.51–0.55	0.59–0.64	FH10	0.48–0.51	0.57–0.63	FH10
	0.56–0.62	0.65–0.71	FH11	0.52–0.57	0.64–0.70	FH11
	0.63–0.68	0.72–0.79	FH12	0.58–0.63	0.71–0.77	FH12
	0.69–0.75	0.80–0.87	FH13	0.64–0.70	0.78–0.85	FH13
	0.76–0.83	0.88–0.96	FH14	0.71–0.77	0.86–0.94	FH14
	0.84–0.91	0.97–1.06	FH15	0.78–0.85	0.95–1.03	FH15
	0.92–1.00	1.07–1.16	FH16	0.86–0.93	1.04–1.13	FH16
	1.01–1.11	1.17–1.28	FH17	0.94–1.03	1.14–1.25	FH17
	1.12–1.22	1.29–1.41	FH18	1.04–1.13	1.26–1.38	FH18
	1.23–1.34	1.42–1.55	FH19	1.14–1.25	1.39–1.52	FH19
	1.35–1.47	1.56–1.71	FH20	1.26–1.37	1.53–1.67	FH20
	1.48–1.62	1.72–1.87	FH21	1.38–1.51	1.68–1.83	FH21
	1.63–1.78	1.88–2.06	FH22	1.52–1.65	1.84–2.01	FH22
	1.79–1.95	2.07–2.26	FH23	1.66–1.81	2.02–2.21	FH23
	1.96–2.15	2.27–2.48	FH24	1.82–1.99	2.22–2.43	FH24
	2.16–2.35	2.49–2.72	FH25	2.00–2.19	2.44–2.66	FH25
	2.36–2.58	2.73–2.99	FH26	2.20–2.39	2.67–2.92	FH26
	2.59–2.83	3.00–3.28	FH27	2.40–2.63	2.93–3.21	FH27
	2.84–3.11	3.29–3.60	FH28	2.64–2.89	3.22–3.53	FH28
	3.12–3.42	3.61–3.95	FH29	2.90–3.17	3.54–3.87	FH29
	3.43–3.73	3.96–4.31	FH30	3.18–3.47	3.88–4.22	FH30
	3.74–4.07	4.32–4.71	FH31	3.48–3.79	4.23–4.61	FH31
	4.08–4.39	4.72–5.14	FH32	3.80–4.11	4.62–4.9	FH32
	4.40–4.87	5.15–5.6	FH33	4.12–4.55	5.0–5.5	FH33
	4.88–5.3	5.7–6.2	FH34	4.56–5.0	5.6–6.0	FH34
	5.4–5.9	6.3–6.8	FH35	5.1–5.5	6.1–6.6	FH35
	6.0–6.4	6.9–7.5	FH36	5.6–5.9	6.7–7.3	FH36
	6.5–7.1	7.6–8.2	FH37	6.0–6.6	7.4–8.0	FH37
	7.2–7.8	8.3–9.0	FH38	6.7–7.2	8.1–8.7	FH38
	7.9–8.5	9.1–9.9	FH39	7.3–7.9	8.8–9.7	FH39
	8.6–9.4	10.0–10.8	FH40	8.0–8.7	9.8–10.5	FH40
	9.5–10.3	10.9–11.9	FH41	8.8–9.5	10.6–11.7	FH41
	10.4–11.3	12.0–13.1	FH42	9.6–10.5	11.8–12.7	FH42
	11.4–12.4	13.2–14.3	FH43	10.6–11.5	12.8–14.0	FH43
	12.5–13.5	14.4–15.7	FH44	11.6–12.6	14.1–15.3	FH44
	13.6–14.9	15.8–17.2	FH45	12.7–13.8	15.4–16.6	FH45
	15.0–16.3	17.3–18.9	FH46	13.9–15.1	16.7–18.3	FH46
	16.4–18.0	19.0–20.8	FH47	15.2–16.7	18.4–20.0	FH47
	18.1–19.8	20.9–22.9	FH48	16.8–18.3	20.1–21.9	FH48
	19.9–21.7	23.0–25.2	FH49	18.4–20.2	22.0–23.9	FH49
	21.8–23.9	25.3–27.6	FH50	20.3–22.2	24.0–26.2	FH50
	24.0–26.2	27.7–30.3	FH51	22.3–24.3	26.3–28.8	FH51
	26.3–28.7	30.4–33.3	FH52	24.4–26.6	28.9–31.4	FH52
	28.8–31.4	33.4–36.4	FH53	26.7–29.1	31.5–34.5	FH53
	31.5–34.5	36.5–39.9	FH54	29.2–32.0	34.6–37.9	FH54
	34.6–37.9	40.0–43.9	FH55	32.1–35.2	38.0–41.9	FH55
	38.0–41.5		FH56	35.3–38.5	42.0–45.0	FH56
	41.6–45.0		FH57	38.6–42.3		FH57

Relays—Current Sensing Protective

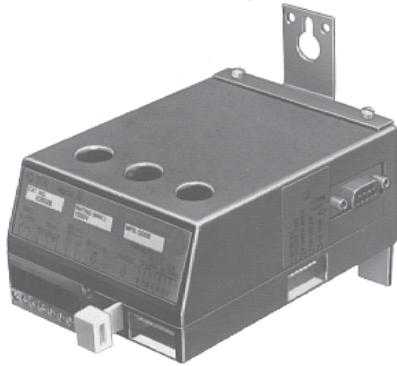

Contents

<i>Description</i>	<i>Page</i>
Contactors—Non-Reversing and Reversing	64
Starters—Non-Reversing and Reversing	70
Relays—Thermal and Fast Trip	91
Thermal Type B, Class 20, Manual Reset	93
Thermal Type A, Class 20, Auto/Manual Reset	96
Type FT Fast Trip, Class 10.	99
Heater Selection.	102
Relays—Current Sensing Protective	
Standards and Certifications	105
Product Selection	105
Dimensions	106

Relays—Current Sensing Protective

Product Description

The IQ500 is a heaterless, current-sensing, solid-state motor protective relay with optional communications capabilities. Several functions are incorporated into the base relay (IQ502/IQ504) as standard:

- Overload (overcurrent) protection
- Phase unbalance and phase loss protection
- Ground current protection (Class II)

The base relay can serve as the initial building block for a motor protection system by adding the IQ500M Special Function Module. The module can address application related motor load functions with the additional features:

- Underload protection
- Long acceleration
- Jam protection
- Load control

The IQ500 can provide a cost-effective alternative to conventional protective relays such as current relays, ground fault relays and phase loss or phase unbalance relays. Used with the PowerNet system, a low-cost, local area communication network, information such as current values, status, setpoint values and cause of trip can be displayed remotely. The IQ500 relay is ideal for a variety of industrial applications such as mining, timber, material handling, air conditioning compressors, wastewater treatment plants and petrochemical industries.

Features

- Overload class is adjustable using DIP switches for 5, 10, 20 or 30 seconds, maximum trip times at six times rated current
- Designed for 1000V and less distribution systems
- Form C (NO/NC) contact on output relay
- Isolated alarm relay output contact
- Communications capability using IMPACC network
- Manual or automatic reset (either a true manual or remote electrical reset)—selectable
- Overload, Class II ground current, phase unbalance and single-phase protection are standard
- LED indication (bi-colored—red/green) for device status, including overload, phase unbalance or ground current trip
- Special Function Module adds protection for underload and jam conditions, also provides for long acceleration
- Optional load control feature available with special function module
- Feed-through current transformer windows for contactors, NEMA Sizes 1–4 (for Size 5 and larger, external current transformers can be used)
- Fits mounting footprint of Eaton’s MORA relay
- Panel or starter mountable
- Cause of trip is held in memory through a power loss
- Bell alarm contact available for remote status indication
- DIP switch provided for setting operating frequency—50 or 60 Hz
- Plug-in terminal block for control power, trip relay and bell alarm relay connections
- Operating temperature: –20° to 60°C (–4° to 140°F)
- DIP switches used to select functions and settings on base relay are clearly marked and covered with screw-on plastic covers
- On the automatic reset, the reset times can be selected for long (90 second) or short (10 second) delay
- Device can be set for different motor full load currents without additional parts or modules
- The underload and jam functions also have separate selectable trip levels and adjustable trip-delay and start-delay settings
- The IQ500M can be used as a load control module that allows “shedding and restoring” a particular load that contributes to the load being monitored
- The PONI (Product Operated Network Interface) card attaches directly to the base relay or special function module for interfacing with the Eaton’s PowerNet communications system
- Localized display can be achieved with the Central Monitoring Unit

Benefits

- No external current transformers are required since they are internal to the IQ500

Optional Benefits

- With the addition of the IQ500M Special Function Module, the enhanced protection includes jam (overtorque) and underload and provides long acceleration time (high inertia load)
- The underload and jam protection functions each have independent Form C output relays as part of the module. In addition, the underload and jam functions each have their own LEDs for status indication

Standards and Certifications

- UL File No. E19223



Product Selection

IQ502A



Current Sensing Protective Relay

Maximum Horsepower				Ampere Rating	Control Voltage	
200V	230V	460–475V	110/120V 50/60 Hz Catalog Number		220/240V 50/60 Hz Catalog Number	
20	25	50	3.4–66A	IQ502A	IQ502B	
60	75	150	10.8–207A	IQ504A	IQ504B	
—	—	—	0.32–5.4A	IQ500LA ①	IQ500LB ①	
Special function module				IQ500M	IQ500M	

Note

① Can be used with external CTs having 5A secondary.

33.2 NEMA Contactors and Starters

A200 Series

Dimensions

Approximate Dimensions in Inches (mm)

Current Sensing Protective Relays

33

IQ504

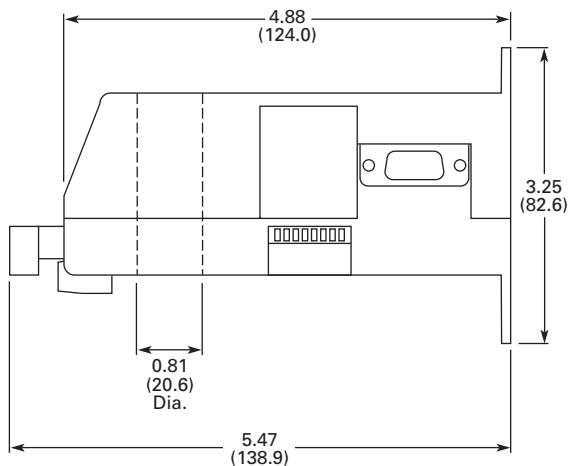
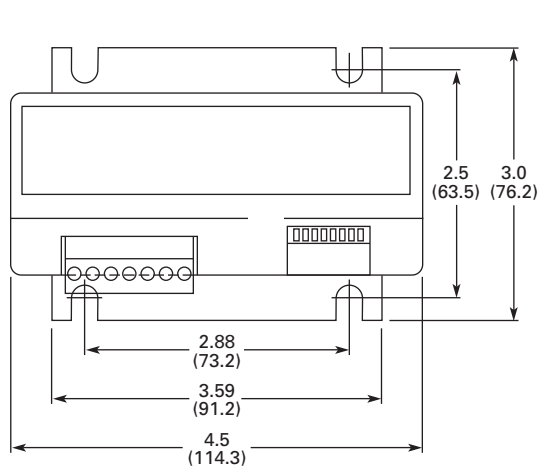

IQ500L and IQ502

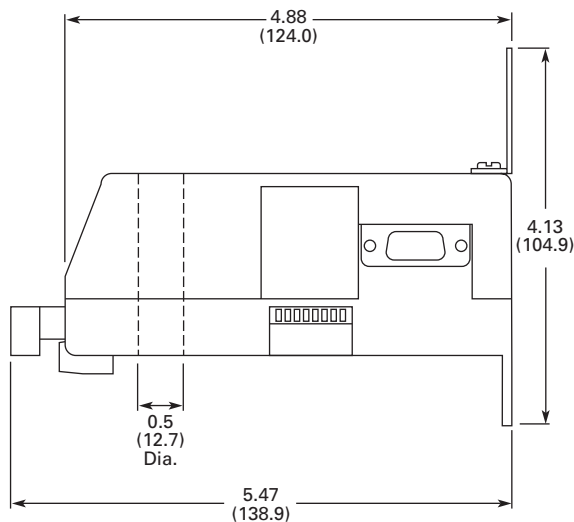
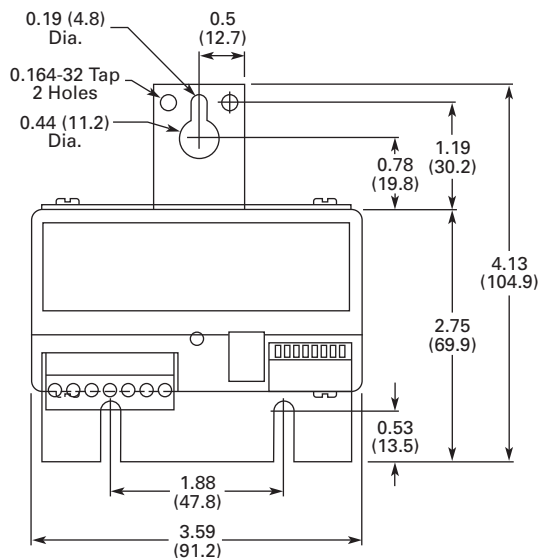

Solenoids—Alternating Current

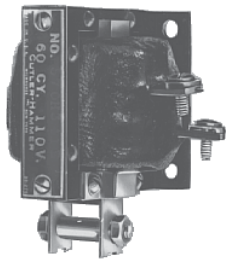

Contents

<i>Description</i>	<i>Page</i>
Solenoids—Alternating Current	
Product Selection	108
Dimensions	109

Product Description

Solenoids from Eaton’s electrical sector are used for a wide variety of applications where straight line motion is to be obtained automatically or at a remote point.

Features

- Plunger and frame are machined to ensure quiet operation
- Push- and pull-type operation
- With and without terminal box
- Plunger provided with connecting pin
- Size C and D solenoids are provided with special bearing to minimize wear in clevis under severe service

Product Selection

When Ordering Specify

- Catalog number

33

10370

AC Solenoids—60 Hz, Continuous Duty

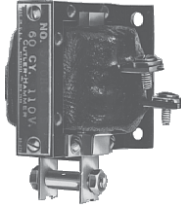

Operating Data ^①													
Magnetic Force in Lbs													
Size	Volt.	Horizontal Position		With Gravity		Against Gravity		Max. Stroke in Inches (mm)	Current		Without Conduit Box Floor Mtg. Catalog Number	Wall Mtg. Catalog Number	With Conduit Box Mtg. ^② Catalog Number
		At 100% Voltage	At 85% Voltage	At 100% Voltage	At 85% Voltage	At 100% Voltage	At 85% Voltage		Inrush	Sealed			
60 Hertz Pull Type													
A	110	0.72	0.50	0.90	0.68	0.55	0.33	1 (25.4)	1.83	0.34	—	10370H1	10370H610
	220	0.72	0.50	0.90	0.68	0.55	0.33	1 (25.4)	0.92	0.17	—	10370H2	10370H611
	440	0.72	0.50	0.90	0.68	0.55	0.33	1 (25.4)	0.45	0.08	—	10370H3	10370H612
B	110	4.2	3	4.5	3.3	3.9	2.7	1 (25.4)	5.4	0.87	10370H57	10370H694	10370H69
	220	4.2	3	4.5	3.3	3.9	2.7	1 (25.4)	2.6	0.42	10370H58	10370H696	10370H70
	440	4.2	3	4.5	3.3	3.9	2.7	1 (25.4)	1.29	0.20	10370H59	10370H697	10370H71
C	110	7	5.25	8	6.25	6	4.25	1.25 (31.8)	10.4	1.07	10370H244	—	10370H256
	220	7	5.25	8	6.25	6	4.25	1.25 (31.8)	5.2	0.52	10370H245	—	10370H257
	440	7	5.25	8	6.25	6	4.25	1.25 (31.8)	2.5	0.26	10370H246	—	10370H258
D	110	12.4	10	13.65	11.25	11.15	8.75	1.25 (31.8)	18	1.58	10370H356	10370H814	10370H368
	220	12.4	10	13.65	11.25	11.15	8.75	1.25 (31.8)	9.3	0.81	10370H357	10370H816	10370H369
	440	12.4	10	13.65	11.25	11.15	8.75	1.25 (31.8)	4.4	0.40	10370H358	10370H817	10370H370
60 Hertz Push Type													
A	110	0.72	0.50	0.90	0.68	0.55	0.33	1 (25.4)	1.83	0.34	—	10370H13	10370H25
	220	0.72	0.50	0.90	0.68	0.55	0.33	1 (25.4)	0.92	0.17	—	10370H14 ^③	10370H26
	440	0.72	0.50	0.90	0.68	0.55	0.33	1 (25.4)	0.45	0.08	—	10370H15	10370H27
B	110	4.2	3	4.5	3.3	3.9	2.7	1 (25.4)	5.4	0.87	10370H81	10370H708	10370H93
	220	4.2	3	4.5	3.3	3.9	2.7	1 (25.4)	2.6	0.42	10370H82	10370H710	10370H94
	440	4.2	3	4.5	3.3	3.9	2.7	1 (25.4)	1.29	0.20	10370H83	10370H711	10370H95
C	110	7	5.25	8	6.25	6	4.25	1.25 (31.8)	10.4	1.07	10370H268	—	10370H280
	220	7	5.25	8	6.25	6	4.25	1.25 (31.8)	5.2	0.52	—	10370H774	10370H281
	440	7	5.25	8	6.25	6	4.25	1.25 (31.8)	2.5	0.26	—	10370H775	10370H282
D	110	12.4	10	13.65	11.25	11.15	8.75	1.25 (31.8)	18	1.58	10370H380	10370H828 ^③	10370H392
	220	12.4	10	13.65	11.25	11.15	8.75	1.25 (31.8)	9.3	0.81	10370H381	10370H830 ^③	10370H393
	440	12.4	10	13.65	11.25	11.15	8.75	1.25 (31.8)	4.4	0.40	10370H382	10370H831 ^③	10370H394

Notes

- ① Mounting of solenoids "with conduit box"—Size A are for wall mounting—Size B, C and D are for floor mounting.
- ② Recommended selection of solenoids on basis of 85% voltage values.
- ③ Part numbers are now obsolete.

Dimensions

Approximate Dimensions in Inches (mm)

AC Solenoids

Wall Mounted

Floor Mounted

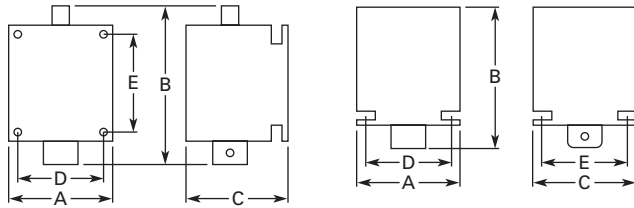

Dimensions and Shipping Weights

Size	Push Type			Mounting		Shipping Weight Lbs (kg)
	Wide A	High B ^①	Deep C	D	E	
Wall Mounted						
A	2.38 (60.5)	3.63 (92.2)	2.25 (57.2)	1.13 (28.7)	1.63 (41.4)	2.0 (0.9)
B	2.63 (66.8)	4.88 (124.0)	3.00 (76.2)	2.00 (50.8)	2.13 (54.1)	2.5 (1.1)
C	3.00 (76.2)	6.13 (155.7)	4.13 (104.9)	2.38 (60.5)	3.13 (79.5)	5.0 (2.3)
D	4.00 (101.6)	6.13 (155.7)	4.13 (104.9)	2.75 (69.9)	3.13 (79.5)	7.0 (3.2)
Floor Mounted						
B	3.13 (79.5)	4.88 (124.0)	3.00 (76.2)	1.50 (38.1)	2.25 (57.2)	2.5 (1.1)
C	3.50 (88.9)	6.13 (155.7)	3.75 (95.3)	1.75 (44.5)	3.13 (79.5)	5.0 (2.3)
D	3.88 (98.6)	6.13 (155.7)	3.75 (95.3)	2.25 (57.2)	3.13 (79.5)	7.0 (3.2)

Size	Pull Type			Mounting		Shipping Weight Lbs (kg)
	Wide A	High B ^①	Deep C	D	E	
A	2.38 (60.5)	2.63 (66.8)	2.25 (57.2)	1.13 (28.7)	1.63 (41.4)	2.0 (0.9)
B	2.63 (66.8)	3.63 (92.2)	3.00 (76.2)	2.00 (50.8)	2.13 (54.1)	2.5 (1.1)
C	3.00 (76.2)	4.88 (124.0)	4.13 (104.9)	2.38 (60.5)	3.13 (79.5)	5.0 (2.3)
D	4.00 (101.6)	4.88 (124.0)	4.13 (104.9)	2.75 (69.9)	3.13 (79.5)	7.0 (3.2)
B	3.13 (79.5)	3.88 (98.6)	3.00 (76.2)	1.50 (38.1)	2.25 (57.2)	2.5 (1.1)
C	3.50 (88.9)	4.88 (124.0)	3.75 (95.3)	1.75 (44.5)	3.13 (79.5)	5.0 (2.3)
D	3.88 (98.6)	4.88 (124.0)	3.75 (95.3)	2.25 (57.2)	3.13 (79.5)	7.0 (3.2)

Note

^① In sealed state.

Shoe Brakes—AC and DC, 511 Series

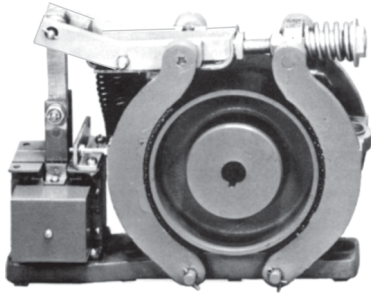

33

Contents

Description

Page

Shoe Brakes—AC and DC Magnetic

Product Selection	111
Dimensions	113

Product Description

Type S Brakes from Eaton's electrical sector are electrically released and spring applied providing "fail-safe" operation. The retarding torque developed is directly proportional to the spring pressure.

Application Description

- Conveyors
- Machine tools
- Printing presses
- Small cranes
- Overhead doors
- Dumb waiters
- Vacuum molding machines
- Carnival rides

Features

The brake wheel is of relatively large size in relation to the torque developed by the brake. This permits use of a larger brake shoe lining and lower shoe pressures. Low shoe pressure, equally distributed over a large lining area, results in even wear of the friction surfaces and even braking torque. The oversize wheel type construction also permits use of a smaller operating solenoid that requires less current for a given torque rating.

DC Brakes

Standard DC brakes are equipped with shunt coils. The magnet coil circuit on DC brakes consists of two separate windings and a protective switch.

Mounting

Type S brakes are designed and recommended for use and mounting only in the horizontal position. Side or vertical mountings are not recommended because the solenoid loading is altered, resulting in accelerated wear and premature coil failure.

Product Selection

When Ordering Specify

- Brake
 - Catalog number plus suffix number for coil
 - Example: 511H1193-41
 - Wheel
 - Catalog number plus suffix number for bore size
 - Example: 511H1150-3

Size S-4 Brake and Wheel

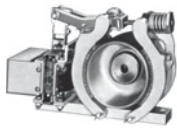

Type S Brakes—Floor Mounting

Torque—lb-ft

Torque—lb-ft		Brake Size	AC			DC		
Continuous	Intermittent ^①		Base Catalog Number ^{②③}	For Type S4, S5-1/2, S7, S10		Base Catalog Number ^{②③}	Coil Voltage	Coil Suffix ^②
				Coil Volts and Hertz	Coil Suffix ^②			
3	3	S-4	511H1194	120V 60 Hz	-39	511H955	120 Vdc	-97
10	10	S-4	511H1193	208V 60 Hz	-45	511H956	240 Vdc	-98
—	15	S-4	511H1192	240V 60 Hz	-40			
—	25	S-5-1/2	511H992	480V 60 Hz	-41	511H957		
—	35	S-5-1/2	511H993	600V 60 Hz	-58	511H994		
50	50	S-7	511H970	110V 50 Hz	-5	511H995		
—	75	S-7	511H971	220V 50 Hz	-6	511H995		
—	85	S-7	511H1195	380V 50 Hz	-7	511H975		
—	110	S-7	511H1196	440V 50 Hz	-8	511H975		
—	—	—	—	550V 50 Hz	-9	511H976		
—	—	—	—	—	—	511H1197		
—	—	—	—	—	—	511H1198		

Notes

- ① Intermittent duty indicates that the coil can be placed across the line continuously for one hour maximum without excessive heating. It is equivalent to 1/2 time ON and 1/2 time OFF.
- ② Add suffix number for coil voltage to base catalog number.
- ③ Does not include wheel.

Brake Selection

The method most generally used to determine required braking torque is to calculate the full load motor torque by the following formula:

$$T = \frac{5252 \times \text{hp}}{\text{rpm}}$$

T = Full load motor torque in lb-ft

hp = Motor horsepower

rpm = Speed of shaft on which brake wheel is mounted

The torque rating of the brake selected should be at least equal to the full load motor torque for the duty considered.

Brake Wheels

Wheel Size in Inches	Min. Bore in Inches (mm)	Max. Bore in Inches (mm)	Pilot Bore in Inches (mm)	WK ²	Straight Bore ^① Base ^③ Catalog Number	Tapered Bore ^② Base ^③ Catalog Number
4.0	0.50 (12.7)	1.38 (35.1)	0.50 (12.7)	0.06	511H1150	511H1151
5.5	0.75 (19.1)	2.00 (50.8)	0.75 (19.1)	0.26	511H1160	511H1161
7.0	1.00 (25.4)	2.25 (57.2)	0.75 (19.1)	0.77	511H1170	511H1171

Brake Wheel Suffix Numbers

Bore Size Suffix Number—Add to Base Catalog Number

Bore ^④ in Inches (mm)	Keyway in Inches	Suffix Number	Bore ^④ in Inches (mm)	Keyway in Inches (mm)	Suffix Number
Standard Bore Sizes					
Pilot bore	None	-1	1.625 (41.28)	3/38 x 3/16	-9
0.625 (15.88)	3/16 x 3/32	-2	1.875 (47.63)	1/2 x 1/4	-10
0.750 (19.05)	3/16 x 3/32	-3	2.125 (53.98)	1/2 x 1/4	-11
0.875 (22.23)	3/16 x 3/32	-4	2.375 (60.33)	5/8 x 5/16	-12
1.000 (25.40)	1/4 x 1/8	-5	2.500 (63.50)	5/8 x 5/16	-63
1.125 (28.58)	1/4 x 1/8	-6	2.625 (66.68)	5/8 x 5/16	-13
1.250 (31.75)	1/4 x 1/8	-7	2.750 (69.85)	5/8 x 5/16	-18
1.375 (34.93)	5/16 x 5/32	-8	2.875 (73.03)	3/4 x 3/8	-14
Non-Standard Bore Sizes					
0.500 (12.70)	1/8 x 1/16	-50	1.687 (42.85)	3/8 x 3/16	-58
0.750 (19.05)	1/4 x 1/8	-51	1.750 (44.45)	3/8 x 3/16	-59
0.875 (22.23)	1/4 x 1/8	-52	1.937 (49.20)	1/2 x 1/4	-60
1.000 (25.40)	5/16 x 5/32	-53	2.000 (50.80)	1/2 x 1/4	-61
1.187 (30.15)	1/4 x 1/8	-54	2.250 (57.15)	1/2 x 1/4	-62
1.375 (34.93)	3/8 x 3/16	-55	—	—	—
1.437 (36.50)	3/8 x 3/16	-56	—	—	—
1.500 (38.10)	3/8 x 3/16	-57	—	—	—

Notes

- ① Bore tolerance: +0.000–0.001 in.
- ② Taper is at rate of 1.25 in per ft on diameter. In bore size selection, use diameter of tapered shaft. Bore tolerance: +0.000–0.005 in.
- ③ Add suffix number for bore size to base catalog number.
- ④ Bore size selected must be between minimum and maximum dimensions listed in brake wheel selection table.

Dimensions

Approximate Dimensions in Inches (mm)

Standard Brake Wheels

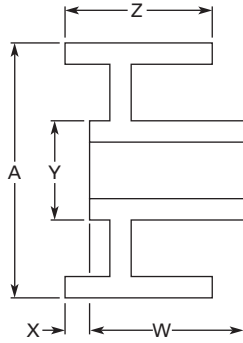

Standard Brake Wheel Dimensions

A	Z	W ^①	X	Y	Bore	
					Max.	Min.
4.00 (101.6)	2.75 (69.9)	1.63 (41.4)	1.38 (35.1)	2.50 (63.5)	1.38 (35.1)	0.50 (12.7)
5.50 (139.7)	3.25 (82.6)	2.00 (50.8)	1.63 (41.4)	3.25 (82.6)	2.00 (50.8)	0.75 (19.1)
7.00 (177.8)	4.25 (108.0)	3.00 (76.2)	1.25 (31.8)	4.00 (101.6)	2.25 (57.2)	1.00 (25.4)

Approximate Shipping Weights

Brake Size	Torque Rating ft-lb	Weight in Lbs (kg)		
		Net — Brake with Wheel	Net — Wheel Only	Boxed — Brake with Wheel
Type "S" AC Shoe Brakes				
S-4	3	15.8 (7.2)	3.4 (1.5)	17.0 (7.7)
S-4	10	15.8 (7.2)	3.4 (1.5)	17.0 (7.7)
S-4	15	15.8 (7.2)	3.4 (1.5)	17.0 (7.7)
S-5-1/2	25	33.2 (15.1)	7.5 (3.4)	36.0 (16.3)
S-5-1/2	35	33.2 (15.1)	7.5 (3.4)	36.0 (16.3)
S-7	50	52.1 (23.7)	18.8 (8.5)	55.0 (25.0)
S-7	75	52.1 (23.7)	18.8 (8.5)	55.0 (25.0)
Type "S" DC Shoe Brakes				
S-4	3	18.0 (8.2)	3.4 (1.5)	20.0 (9.1)
S-4	10	18.0 (8.2)	3.4 (1.5)	20.0 (9.1)
S-4	15	18.0 (8.2)	3.4 (1.5)	20.0 (9.1)
S-5-1/2	25	35.0 (15.9)	7.5 (3.4)	38.0 (17.3)
S-5-1/2	35	35.0 (15.9)	7.5 (3.4)	38.0 (17.3)
S-7	50	54.0 (24.5)	18.8 (8.5)	58.0 (26.3)
S-7	75	54.0 (24.5)	18.8 (8.5)	58.0 (26.3)
S-7	85	54.0 (24.5)	18.8 (8.5)	58.0 (26.3)
S-7	110	54.0 (24.5)	18.8 (8.5)	58.0 (26.3)

Note

① Hub lengths other than standard are not available.

33.4 NEMA Contactors and Starters

Shoe Brakes—AC and DC Magnetic

Approximate Dimensions in Inches (mm)

Type S4, S5-1/2 and S7 Solenoid Operated

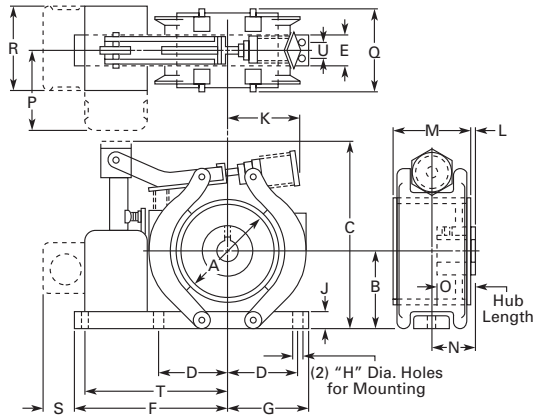

Type "S" AC Shoe Brakes

Brake Size	Torque Rating ft-lb	A	B ^①	C	D	E	F	G	H	J	K	L	M	N	O	P	Q	R
S-4	3	4.00 (101.6)	2.88 (73.2)	7.50 (190.5)	2.63 (66.8)	1.25 (31.8)	7.50 (190.5)	3.13 (79.5)	0.38 (9.7)	0.63 (16.0)	2.88 (73.2)	0.25 (6.4)	2.75 (69.9)	1.63 (41.4)	1.63 (41.4)	2.88 (73.2)	3.00 (76.2)	3.13 (79.5)
S-4	10	4.00 (101.6)	2.88 (73.2)	7.50 (190.5)	2.63 (66.8)	1.25 (31.8)	7.50 (190.5)	3.13 (79.5)	0.38 (9.7)	0.63 (16.0)	2.88 (73.2)	0.25 (6.4)	2.75 (69.9)	1.63 (41.4)	1.63 (41.4)	2.88 (73.2)	3.00 (76.2)	3.13 (79.5)
S-4	15	4.00 (101.6)	2.88 (73.2)	7.50 (190.5)	2.63 (66.8)	1.25 (31.8)	7.50 (190.5)	3.13 (79.5)	0.38 (9.7)	0.63 (16.0)	2.88 (73.2)	0.25 (6.4)	2.75 (69.9)	1.63 (41.4)	1.63 (41.4)	2.88 (73.2)	3.00 (76.2)	3.13 (79.5)
S-5-1/2	25	5.50 (139.7)	4.00 (101.6)	9.50 (241.3)	3.50 (88.9)	2.00 (50.8)	8.38 (212.9)	4.13 (104.9)	0.44 (11.2)	1.00 (25.4)	4.88 (124.0)	0.38 (9.7)	3.25 (82.6)	2.00 (50.8)	2.00 (50.8)	3.13 (79.5)	3.75 (95.3)	3.13 (79.5)
S-5-1/2	35	5.50 (139.7)	4.00 (101.6)	9.50 (241.3)	3.50 (88.9)	2.00 (50.8)	8.38 (212.9)	4.13 (104.9)	0.44 (11.2)	1.00 (25.4)	7.88 (200.2)	0.38 (9.7)	3.25 (82.6)	2.00 (50.8)	2.00 (50.8)	3.13 (79.5)	3.75 (95.3)	3.13 (79.5)
S-7	50	7.00 (177.8)	5.00 (127.0)	11.50 (292.1)	4.38 (111.3)	2.50 (63.5)	9.50 (241.3)	5.00 (127.0)	0.56 (14.2)	1.00 (25.4)	6.00 (152.4)	—	4.25 (108.0)	2.13 (54.1)	3.00 (76.2)	3.13 (79.5)	4.75 (120.7)	3.13 (79.5)
S-7	75	7.00 (177.8)	5.00 (127.0)	11.50 (292.1)	4.38 (111.3)	2.50 (63.5)	9.50 (241.3)	5.00 (127.0)	0.56 (14.2)	1.00 (25.4)	6.00 (152.4)	—	4.25 (108.0)	2.13 (54.1)	3.00 (76.2)	3.13 (79.5)	4.75 (120.7)	3.13 (79.5)

Type "S" DC Shoe Brakes

Brake Size	Torque Rating ft-lb	A	B ^①	C	D	E	F	G	H	J	K	L	M	N	O	P	Q	R
S-4	3	4.00 (101.6)	3.50 (88.9)	8.00 (203.2)	2.63 (66.8)	1.25 (31.8)	7.56 (192.0)	3.25 (82.6)	0.38 (9.7)	0.75 (19.1)	2.88 (73.2)	0.25 (6.4)	2.75 (69.9)	1.63 (41.4)	1.63 (41.4)	2.63 (66.8)	3.00 (76.2)	4.06 (103.1)
S-4	10	4.00 (101.6)	3.50 (88.9)	8.00 (203.2)	2.63 (66.8)	1.25 (31.8)	7.56 (192.0)	3.25 (82.6)	0.38 (9.7)	0.75 (19.1)	2.88 (73.2)	0.25 (6.4)	2.75 (69.9)	1.63 (41.4)	1.63 (41.4)	2.63 (66.8)	3.00 (76.2)	4.06 (103.1)
S-4	15	4.00 (101.6)	3.50 (88.9)	8.00 (203.2)	2.63 (66.8)	1.25 (31.8)	7.56 (192.0)	3.25 (82.6)	0.38 (9.7)	0.75 (19.1)	2.88 (73.2)	.25 (6.4)	2.75 (69.9)	1.63 (41.4)	1.63 (41.4)	2.63 (66.8)	3.00 (76.2)	4.06 (103.1)
S-5-1/2	25	5.50 (139.7)	4.00 (101.6)	9.50 (241.3)	3.50 (88.9)	2.00 (50.8)	8.38 (212.9)	4.13 (104.9)	0.44 (11.2)	0.75 (19.1)	4.88 (124.0)	0.38 (9.7)	3.25 (82.6)	2.00 (50.8)	2.00 (50.8)	2.88 (73.2)	3.75 (95.3)	4.06 (103.1)
S-5-1/2	35	5.50 (139.7)	4.00 (101.6)	9.50 (241.3)	3.50 (88.9)	2.00 (50.8)	8.38 (212.9)	4.13 (104.9)	0.44 (11.2)	0.75 (19.1)	4.88 (124.0)	0.38 (9.7)	3.25 (82.6)	2.00 (50.8)	2.00 (50.8)	2.88 (73.2)	3.75 (95.3)	4.06 (103.1)
S-7	50	7.00 (177.8)	5.00 (127.0)	11.50 (292.1)	4.38 (111.3)	2.50 (63.5)	9.50 (241.3)	5.00 (127.0)	0.56 (14.2)	0.75 (19.1)	6.00 (152.4)	—	4.25 (108.0)	2.13 (54.1)	3.00 (76.2)	2.88 (73.2)	4.88 (124.0)	4.06 (103.1)
S-7	75	7.00 (177.8)	5.00 (127.0)	11.50 (292.1)	4.38 (111.3)	2.50 (63.5)	9.50 (241.3)	5.00 (127.0)	0.56 (14.2)	0.75 (19.1)	6.00 (152.4)	—	4.25 (108.0)	2.13 (54.1)	3.00 (76.2)	2.88 (73.2)	4.88 (124.0)	4.06 (103.1)
S-7	85	7.00 (177.8)	5.00 (127.0)	11.50 (292.1)	4.38 (111.3)	2.50 (63.5)	9.50 (241.3)	5.00 (127.0)	0.56 (14.2)	0.75 (19.1)	6.00 (152.4)	—	4.25 (108.0)	2.13 (54.1)	3.00 (76.2)	2.88 (73.2)	4.88 (124.0)	4.06 (103.1)
S-7	110	7.00 (177.8)	5.00 (127.0)	11.50 (292.1)	4.38 (111.3)	2.50 (63.5)	9.50 (241.3)	5.00 (127.0)	0.56 (14.2)	0.75 (19.1)	6.00 (152.4)	—	4.25 (108.0)	2.13 (54.1)	3.00 (76.2)	2.88 (73.2)	4.88 (124.0)	4.06 (103.1)

Note

① Open type brake only.

Reference Data

IEC Utilization Categories

(See also IEC/EN 60947-1; 2.1.18/IEV 441-17-19)

A combination of specified requirements relating to the condition in which the switching device or fuse fulfills its purpose and selected to represent a characteristic group of real-life applications. The specified requirements may, for example, relate to the values of making and breaking capacity and other characteristic values, data concerning associated circuits and the applicable conditions of use and operational behavior.

Used in Technical Data and Formulas

Code	Descriptions
DF	Duty factory
I_{Dn}	Response value of earth-fault release
I_{cm}	Rated short-circuit making capacity
I_{cn}	Rated short-circuit breaking capacity
I_{cs}	Rated service short-circuit breaking capacity
I_{cu}	Rated ultimate short-circuit breaking capacity
I_{cw}	Rated short-time withstand current
I_e	Rated operational current
I_k	Transformer initial short-circuit AC current
I_L	Load monitoring response value
I_n	Rated current
I_{NT}	Transformer rated current
I_{PK}	Rated peak withstand current
I_q	Rated conditional short-circuit current
I_r	Overcurrent release set value
I_{rm}	Response value of non-delayed short-circuit release
I_i	Response value of non-delayed short-circuit release
I_{rmf}	Response value of fixed, non-delayed short-circuit release

Code	Descriptions
I_{mv}	Response value of short-time delayed short-circuit release
I_{sd}	Response value of short-time delayed short-circuit release
I_T	Response value of earth-fault release
I_g	Response value of earth-fault release
I_{th}	Conventional free air thermal current
I_{the}	Conventional thermal current of enclosed devices
I_u	Rated uninterrupted current
S_{NT}	Transformer rating
t_r	Time delay of overload release response
t_T	Time delay of earth-fault release response
t_g	Time delay of earth-fault release response
t_v	Time delay of short-circuit release response
U_c	Rated actuating voltage
U_e	Rated operational voltage
U_i	Rated insulation voltage
U_{imp}	Rated impulse withstand voltage
U_k	Transformer short-circuit voltage
U_s	Rated control voltage

Annex A (informative)

Examples of Utilization Categories for Low-Voltage Switchgear and Controlgear ^①

Category	Typical Applications	Relevant IEC Product Standard
Nature of Current—AC		
AC-1	Non-inductive or slightly inductive loads, resistance furnaces	60947-4-1
AC-2	Slip-ring motors: starting, switching off	60947-4-1
AC-3	Squirrel-cage motors: starting, switching off motors during running	60947-4-1
AC-4	Squirrel-cage motors: starting, plugging ^② , inching ^③	60947-4-1
AC-5a	Switching of electric discharge lamp controls	60947-4-1
AC-5b	Switching of incandescent lamps	60947-4-1
AC-6a	Switching of transformers	60947-4-1
AC-6b	Switching of capacitor banks	60947-4-1
AC-7a	Slightly inductive loads for household appliances and similar applications	61095
AC-7b	Motor-loads for household applications	61095
AC-8a	Hermetic refrigerant compressor motor control with manual resetting of overload releases	60947-4-1
AC-8b	Hermetic refrigerant compressor motor control with automatic resetting of overload releases	60947-4-1
AC-12	Control of resistive loads and solid-state loads with isolation by optocouplers	60947-5-1
AC-12	Control of resistive loads and solid-state loads with optical isolation	60947-5-2
AC-13	Control of solid-state loads with transformer isolation	60947-5-1
AC-14	Control of small electromagnetic loads	60947-5-1
AC-15	Control of AC electromagnetic loads	60947-5-1
AC-20	Connecting and disconnecting under no-load conditions	60947-3
AC-21	Switching of resistive loads, including moderate overloads	60947-3
AC-22	Switching of mixed resistive and inductive loads, including moderate overloads	60947-3
AC-23	Switching of motor loads or other highly inductive loads	60947-3
AC-31	Non inductive or slightly inductive loads	60947-6-1
AC-33	Motor loads or mixed loads including motors, resistive loads and up to 30% incandescent lamp loads	60947-6-1
AC-35	Electric discharge lamp loads	60947-6-1
AC-36	Incandescent lamp loads	60947-6-1
AC-40	Distribution circuits comprising mixed resistive and reactive loads having a resultant inductive reactance	60947-6-2
AC-41	Non-inductive or slightly inductive loads, resistance furnaces	60947-6-2
AC-42	Slip-ring motors: starting, switching off	60947-6-2
AC-43	Squirrel cage motors: starting, switching off motors during running	60947-6-2
AC-44	Squirrel cage motors: starting, plugging ^② , inching ^③	60947-6-2
AC-45a	Switching of electric discharge lamp controls	60947-6-2
AC-45b	Switching of incandescent lamps	60947-6-2
AC-51	Non-inductive or slightly inductive loads, resistance furnaces	60947-4-3
AC-52a	Control of slip ring motor stators: 8 h duty with on-load currents for start, acceleration, run	60947-4-2
AC-52b	Control of slip ring motor stators: intermittent duty	60947-4-2
AC-53a	Control of squirrel cage motors: 8 h duty with on-load currents for start, acceleration, run	60947-4-2
AC-53b	Control of squirrel cage motors: intermittent duty	60947-4-2

Notes

^① 60947-1 © IEC: 2004.

^② Plugging is understood to be stopping or reversing the motor rapidly by reversing motor primary connections while the motor is running.

^③ Inching is understood to be energizing a motor once or repeatedly for short periods to obtain small movements of the driven mechanism.

Examples of Utilization Categories for Low-Voltage Switchgear and Controlgear, continued ^①

Category	Typical Applications	Relevant IEC Product Standard
Nature of Current—AC, continued		
AC-55a	Switching of electric discharge lamp controls	60947-4-3
AC-55b	Switching of incandescent lamps	60947-4-3
AC-56a	Switching of transformers	60947-4-3
AC-56b	Switching of capacitor banks	60947-4-3
AC-58a	Control of hermetic refrigerant compressor motors with automatic resetting of overload releases: 8 h duty with on-load currents for start, acceleration, run	60947-4-2
AC-58b	Control of hermetic refrigerant compressor motors with automatic resetting of overload releases: intermittent duty	60947-4-2
AC-140	Control of small electromagnetic loads with holding (closed) current $\leq 0,2$ A, e.g. contactor relays	60947-5-2
Nature of Current—AC and DC		
A	Protection of circuits, with no rated short-time withstand current	60947-2
B	Protection of circuits, with a rated short-time withstand current	60947-2
Nature of Current—DC		
DC-1	Non-inductive or slightly inductive loads, resistance furnaces	60947-4-1
DC-3	Shunt-motors: starting, plugging ^② , inching ^③ , dynamic breaking of motors	60947-4-1
DC-5	Series-motors: starting, plugging ^② , inching ^③ , dynamic breaking of motors	60947-4-1
DC-6	Switching of incandescent lamps	60947-4-1
DC-12	Control of resistive loads and solid-state loads with isolation by optocouplers	60947-5-1
DC-12	Control of resistive loads and solid-state loads with optical isolation	60947-5-2
DC-13	Control of electromagnets	60947-5-1
DC-13	Control of electromagnets	60947-5-2
DC-14	Control of electromagnetic loads having economy resistors in circuit	60947-5-1
DC-20	Connecting and disconnecting under no-load conditions	60947-3
DC-21	Switching of resistive loads, including moderate overloads	60947-3
DC-22	Switching of mixed resistive and inductive loads, including moderate overloads (e.g. shunt motors)	60947-3
DC-23	Switching of motor loads or other highly inductive loads (e.g. series motors)	60947-3
DC-31	Resistive loads	60947-6-1
DC-33	Motor loads or mixed loads including motors	60947-6-1
DC-36	Incandescent lamp loads	60947-6-1
DC-40	Distribution circuits comprising mixed resistive and reactive loads having a resultant inductive reactance	60947-6-2
DC-41	Non-inductive or slightly inductive loads, resistance furnaces	60947-6-2
DC-43	Shunt-motors: starting, plugging ^② , inching ^③ , dynamic breaking of DC	60947-6-2
DC-45	Series-motors: starting, plugging ^② , inching ^③ , dynamic breaking of DC	60947-6-2
DC-46	Switching of incandescent lamps	60947-6-2

Notes

^① 60947-1 © IEC: 2004.

^② Plugging is understood to be stopping or reversing the motor rapidly by reversing motor primary connections while the motor is running.

^③ Inching is understood to be energizing a motor once or repeatedly for short periods to obtain small movements of the driven mechanism.

Motor Ratings Data

Ampere Rating of AC and DC Motors

Ampere ratings of motors vary somewhat, depending upon the type of motor. The values given below are for drip-proof, Class B insulated (T Frame) where available, 1.15 service factor, NEMA Design B motors. These values represent an average full load motor current which was calculated from the motor performance data published by several motor manufacturers. In the case of high torque squirrel cage motors, the ampere ratings will be at least 10% greater than the values given in the following table.

Caution—These average ratings could be high or low for a specific motor and therefore heater coil selection on this basis always involves risk. For fully reliable motor protection, select heater coils on the basis of full load current rating as shown on the motor nameplate.

Ampere Ratings of Three-Phase, 60 Hz, AC Induction Motor

hp	Syn. Speed RPM	Current in Amperes					
		200V	230V	380V ①	460V	575V	2200V
1/4	1800	1.09	.95	0.55	0.48	0.38	—
	1200	1.61	1.40	0.81	0.70	0.56	—
	900	1.84	1.60	0.93	0.80	0.64	—
1/3	1800	1.37	1.19	0.69	0.60	0.48	—
	1200	1.83	1.59	0.92	0.80	0.64	—
	900	2.07	1.80	1.04	0.90	0.72	—
1/2	1800	1.98	1.72	0.99	0.86	0.69	—
	1200	2.47	2.15	1.24	1.08	0.86	—
	900	2.74	2.38	1.38	1.19	0.95	—
3/4	1800	2.83	2.46	1.42	1.23	0.98	—
	1200	3.36	2.92	1.69	1.46	1.17	—
	900	3.75	3.26	1.88	1.63	1.30	—
1	3600	3.22	2.80	1.70	1.40	1.12	—
	1800	4.09	3.56	2.06	1.78	1.42	—
	1200	4.32	3.76	2.28	1.88	1.50	—
	900	4.95	4.30	2.60	2.15	1.72	—
1-1/2	3600	5.01	4.36	2.64	2.18	1.74	—
	1800	5.59	4.86	2.94	2.43	1.94	—
	1200	6.07	5.28	3.20	2.64	2.11	—
	900	6.44	5.60	3.39	2.80	2.24	—
2	3600	6.44	5.60	3.39	2.80	2.24	—
	1800	7.36	6.40	3.87	3.20	2.56	—
	1200	7.87	6.84	4.14	3.42	2.74	—
	900	9.09	7.90	4.77	3.95	3.16	—
3	3600	9.59	8.34	5.02	4.17	3.34	—
	1800	10.8	9.40	5.70	4.70	3.76	—
	1200	11.7	10.2	6.20	5.12	4.10	—
	900	13.1	11.4	6.90	5.70	4.55	—
5	3600	15.5	13.5	8.20	6.76	5.41	—
	1800	16.6	14.4	8.74	7.21	5.78	—
	1200	18.2	15.8	9.59	7.91	6.32	—
	900	18.3	15.9	9.60	7.92	6.33	—
7-1/2	3600	22.4	19.5	11.8	9.79	7.81	—
	1800	24.7	21.5	13.0	10.7	8.55	—
	1200	25.1	21.8	13.2	10.9	8.70	—
	900	26.5	23.0	13.9	11.5	9.19	—
10	3600	29.2	25.4	15.4	12.7	10.1	—
	1800	30.8	26.8	16.3	13.4	10.7	—
	1200	32.2	28.0	16.9	14.0	11.2	—
	900	35.1	30.5	18.5	15.2	12.2	—
15	3600	41.9	36.4	22.0	18.2	14.5	—
	1800	45.1	39.2	23.7	19.6	15.7	—
	1200	47.6	41.4	25.0	20.7	16.5	—
	900	51.2	44.5	26.9	22.2	17.8	—
20	3600	58.0	50.4	30.5	25.2	20.1	—
	1800	58.9	51.2	31.0	25.6	20.5	—
	1200	60.7	52.8	31.9	26.4	21.1	—
	900	63.1	54.9	33.2	27.4	21.9	—

Note

① 380V 50 Hz.

Ampere Ratings of Three-Phase, 60 Hz, AC Induction Motor, continued

hp	Syn. Speed RPM	Current in Amperes					
		200V	230V	380V ①	460V	575V	2200V
25	3600	69.9	60.8	36.8	30.4	24.3	—
	1800	74.5	64.8	39.2	32.4	25.9	—
	1200	75.4	65.6	39.6	32.8	26.2	—
	900	77.4	67.3	40.7	33.7	27.0	—
30	3600	84.8	73.7	44.4	36.8	29.4	—
	1800	86.9	75.6	45.7	37.8	30.2	—
	1200	90.6	78.8	47.6	39.4	31.5	—
	900	94.1	81.8	49.5	40.9	32.7	—
40	3600	111	96.4	58.2	48.2	38.5	—
	1800	116	101	61.0	50.4	40.3	—
	1200	117	102	61.2	50.6	40.4	—
	900	121	105	63.2	52.2	41.7	—
50	3600	138	120	72.9	60.1	48.2	—
	1800	143	124	75.2	62.2	49.7	—
	1200	145	126	76.2	63.0	50.4	—
	900	150	130	78.5	65.0	52.0	—
60	3600	164	143	86.8	71.7	57.3	—
	1800	171	140	90.0	74.5	59.4	—
	1200	173	150	91.0	75.0	60.0	—
	900	177	154	93.1	77.0	61.5	—
75	3600	206	179	108	89.6	71.7	—
	1800	210	183	111	91.6	73.2	—
	1200	212	184	112	92.0	73.5	—
	900	222	193	117	96.5	77.5	—
100	3600	266	231	140	115	92.2	—
	1800	271	236	144	118	94.8	23.6
	1200	275	239	145	120	95.6	24.2
	900	290	252	153	126	101	24.8
125	3600	—	292	176	146	116	—
	1800	—	293	177	147	117	29.2
	1200	—	298	180	149	119	29.9
	900	—	305	186	153	122	30.9
150	3600	—	343	208	171	137	—
	1800	—	348	210	174	139	34.8
	1200	—	350	210	174	139	35.5
	900	—	365	211	183	146	37.0
200	3600	—	452	257	226	181	—
	1800	—	458	265	229	184	46.7
	1200	—	460	266	230	184	47.0
	900	—	482	279	241	193	49.4
250	3600	—	559	338	279	223	—
	1800	—	568	343	284	227	57.5
	1200	—	573	345	287	229	58.5
	900	—	600	347	300	240	60.5
300	1800	—	678	392	339	271	69.0
	1200	—	684	395	342	274	70.0
400	1800	—	896	518	448	358	91.8
500	1800	—	1110	642	555	444	116

Single-Phase AC Motors

The following values of full-load currents are for motors running at usual speeds and motors with normal torque characteristics. Motors built for especially low speeds or high torques may have higher full-load currents and multispeed motors will have full-load current varying with speed, in which case the nameplate current ratings shall be used.

The voltages listed are rated motor voltages. The currents listed shall be permitted for system voltage ranges of 110 to 120 and 220 to 240V.

Table 430.248. Full-Load Currents in Amperes, Single-Phase Alternating-Current Motors

hp	115V	200V	208V	230V
1/6	4.4	2.5	2.4	2.2
1/4	5.8	3.3	3.2	2.9
1/3	7.2	4.1	4.0	3.6
1/2	9.8	5.6	5.4	4.9
3/4	13.8	7.9	7.6	6.9
1	16	9.2	8.8	8
1-1/2	20	11.5	11	10
2	24	13.8	13.2	12
3	34	19.6	18.7	17
5	56	32.2	30.8	28
7-1/2	80	46	44	40
10	100	57.5	55	50

Note

① 380V 50 Hz.

33.5

NEMA Contactors and Starters

Reference Data

DC Motors

The following values of full-load currents are for motors running at base speed.

These are average direct-current quantities.

Three-Phase AC Motors

The following values of full-load currents are typical for motors running at speeds usual for belted motors and motors with normal torque characteristics.

Motors built for low speeds (1,200 RPM or less) or high torques may require more running current and multispeed motors will have

full-load current varying with speed. In these cases the nameplate current rating shall be used.

The voltages listed are rated motor voltages. The currents listed shall be permitted for system voltage ranges of 110 to 120, 220 to 240, 440 to 480 and 550 to 600V.

Table 430.247. Full-Load Current in Amperes, Direct-Current Motors

hp	Armature Voltage Rating ^①		Ampere Capacity of Fuses for Motors Recommended Values	
	120V	240V	120V	240V
1/4	3.1	1.6	5	3
1/3	4.1	2.0	5	3
1/2	5.4	2.7	7	3
3/4	7.6	3.8	10	5
1	9.5	4.7	15	7
1-1/2	13.2	6.6	20	10
2	17	8.5	25	12
3	25	12.2	30	15
5	40	20	50	25
7-1/2	58	29	80	40
10	76	38	100	50
15	—	55	—	75
20	—	72	—	100
25	—	89	—	125
30	—	106	—	150
40	—	140	—	200
50	—	173	—	250
60	—	206	—	275
75	—	255	—	350
100	—	341	—	500
125	—	425	—	600
150	—	506	—	—
200	—	675	—	—

Table 430.250. Full-Load Current Three-Phase Alternating-Current Motors

hp	Induction Type Squirrel Cage and Wound-Rotor Amperes						Synchronous Type Unity Power Factor ^② Amperes				
	115V	200V	208V	230V	460V	575V	2300V	230V	460V	575V	2300V
1/2	4.4	2.5	2.4	2.2	1.1	0.9	—	—	—	—	—
3/4	6.4	3.7	3.5	3.2	1.6	1.3	—	—	—	—	—
1	8.4	4.8	4.6	4.2	2.1	1.7	—	—	—	—	—
1-1/2	12.0	6.9	6.6	6.0	3.0	2.4	—	—	—	—	—
2	13.6	7.8	7.5	6.8	3.4	2.7	—	—	—	—	—
3	—	11.0	10.6	9.6	4.8	3.9	—	—	—	—	—
5	—	17.5	16.7	15.2	7.6	6.1	—	—	—	—	—
7-1/2	—	25.3	24.2	22	11	9	—	—	—	—	—
10	—	32.2	30.8	28	14	11	—	—	—	—	—
15	—	48.3	46.2	42	21	17	—	—	—	—	—
20	—	62.1	59.4	54	27	22	—	—	—	—	—
25	—	78.2	74.8	68	34	27	—	53	26	21	—
30	—	92	88	80	40	32	—	63	32	26	—
40	—	120	114	104	52	41	—	83	41	33	—
50	—	150	143	130	65	52	—	104	52	42	—
60	—	177	169	154	77	62	16	123	61	49	12
75	—	221	211	192	96	77	20	155	78	62	15
100	—	285	273	248	124	99	26	202	101	81	20
125	—	359	343	312	156	125	31	253	126	101	25
150	—	414	396	360	180	144	37	302	151	121	30
200	—	552	528	480	240	192	49	400	201	161	40
250	—	—	—	—	302	242	60	—	—	—	—
300	—	—	—	—	361	289	72	—	—	—	—
350	—	—	—	—	414	336	83	—	—	—	—
400	—	—	—	—	477	382	95	—	—	—	—
450	—	—	—	—	515	412	103	—	—	—	—
500	—	—	—	—	590	472	118	—	—	—	—

Notes

- ① These are average direct-current quantities.
- ② For 90 and 80 percent power factor, the above figures shall be multiplied by 1.1 and 1.25 respectively.