

## G310 & TX700T BACKLIGHT ASSEMBLIES

**CAUTION** - Backlight is not field replaceable for hazardous location applications. Unit must be returned to Red Lion Controls for repair.

**WARNING - EXPLOSION HAZARD - DO NOT DISCONNECT EQUIPMENT UNLESS POWER HAS BEEN DISCONNECTED AND THE AREA IS KNOWN TO BE NON-HAZARDOUS.**

**WARNING - EXPLOSION HAZARD - THE AREA MUST BE KNOWN TO BE NON-HAZARDOUS BEFORE SERVICING/ REPLACING THE UNIT AND BEFORE INSTALLING OR REMOVING I/O, INVERTER, BACKLIGHT, WIRING AND BATTERY.**

**CAUTION: RISK OF ELECTRIC SHOCK**  
 The inverter board supplies the high voltage to operate the backlight. Touching the inverter board may result in injury to personnel. Disconnect all power before installing or removing backlight assembly.

### G310 BACKLIGHT REPLACEMENT PROCEDURE

1. Remove the power and PLC Communications connectors from the unit.
2. Remove the five screws from the rear cover.
3. Locate the inverter board (refer to Figure 1).
4. Carefully remove heat shrink tubing from the backlight connector on the inverter board.
5. Carefully remove the backlight connector from its connector housing on the inverter board. (refer to Figure 1).
6. Depress the backlight release tab and carefully remove the backlight as indicated in Figure 2.
7. To install the new backlight assembly, reverse the above steps. Ensure that the florescent tubes of the backlight assembly face towards the display. Use caution when inserting the new assembly so that it is not twisted or pushed on an angle. The backlight assembly is fragile and may easily be broken.
8. Apply the enclosed label to the rear cover in the area indicated in Figure 3. Field replacement of the backlight assembly voids the Hazardous Locations rating of this unit.

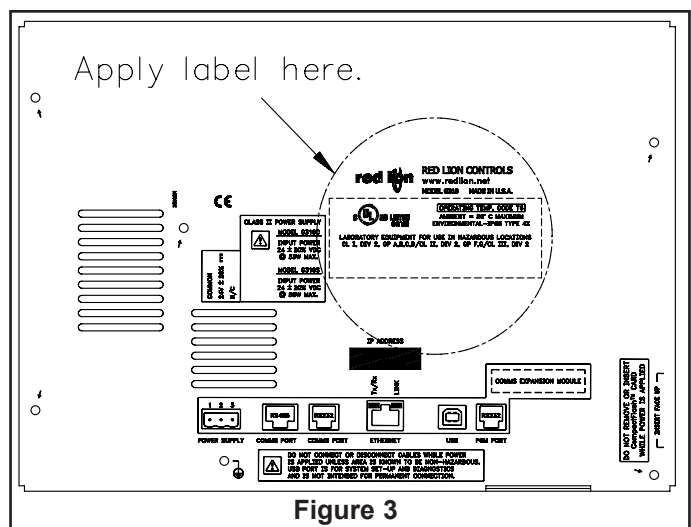
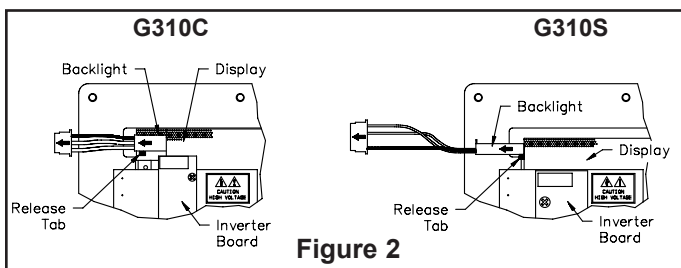
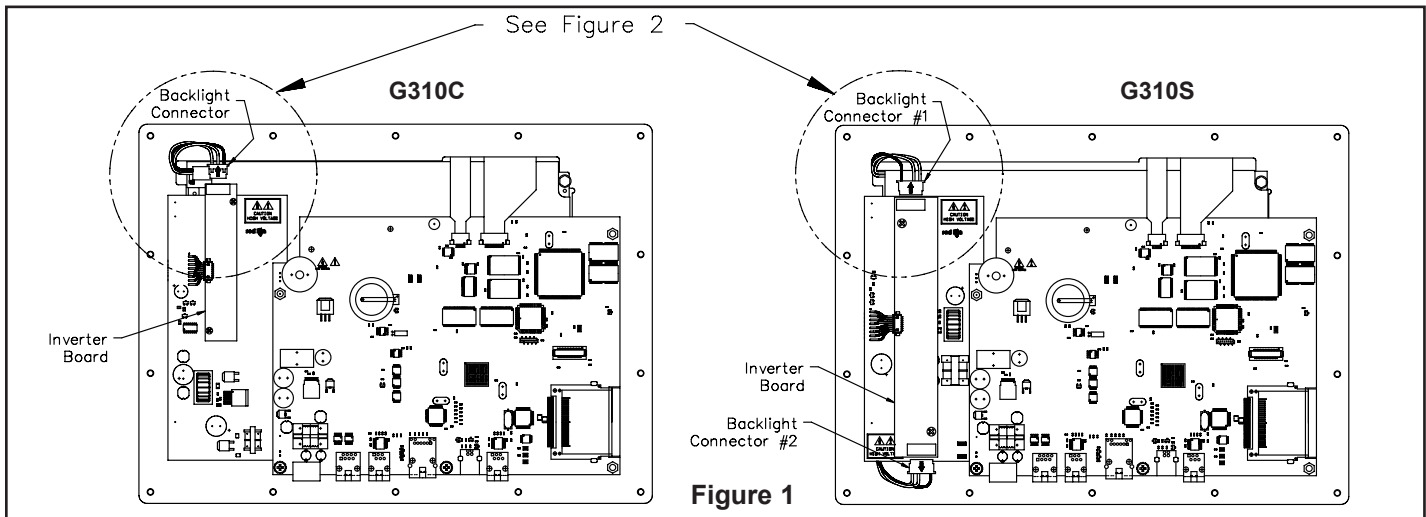

### ORDERING INFORMATION

MODEL NO.	DESCRIPTION	PART NUMBER
G310	G310C Backlight Assembly	G3BR10C0
	G310S Backlight Assembly	G3BR10S0

# TX700T BACKLIGHT REPLACEMENT PROCEDURE



WARNING - EXPLOSION HAZARD - THE AREA MUST BE KNOWN TO BE NON-HAZARDOUS BEFORE SERVICING/ REPLACING THE UNIT AND BEFORE INSTALLING OR REMOVING I/O, INVERTER, BACKLIGHT, WIRING AND BATTERY.



WARNING - EXPLOSION HAZARD - DO NOT DISCONNECT EQUIPMENT UNLESS POWER HAS BEEN DISCONNECTED AND THE AREA IS KNOWN TO BE NON-HAZARDOUS.

1. Remove the power and PLC Communications connectors from the unit.
2. Remove the four screws from the rear cover.
3. Locate the inverter board (refer to Figure 1).
4. Carefully remove the backlight connector from its connector housing on the inverter board. (refer to Figure 2).
5. Depress the backlight release tab and carefully remove the backlight as indicated in Figure 3.
6. To install the new backlight assembly, reverse the above steps. Ensure that the florescent tubes of the backlight assembly face towards the display. Use caution when inserting the new assembly so that it is not twisted or pushed on an angle. The backlight assembly is fragile and may easily be broken.

Figure 1

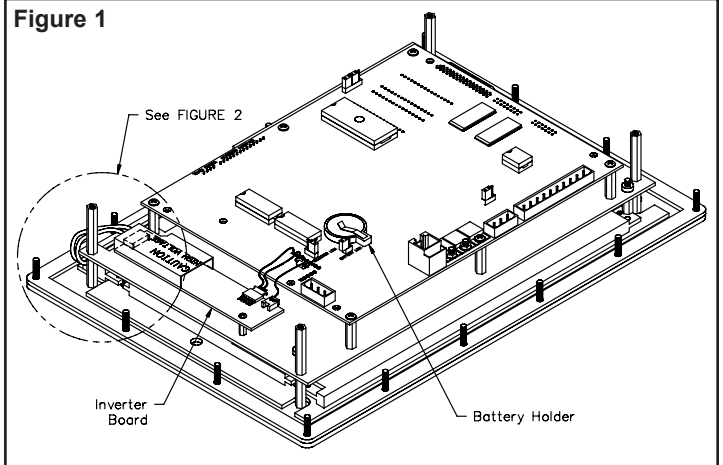

### CAUTION: RISK OF ELECTRIC SHOCK

The inverter board, attached to the mounting plate, supplies the high voltage to operate the backlight. Touching the inverter board may result in injury to personnel. Disconnect all power before installing or removing backlight assembly.

Figure 2

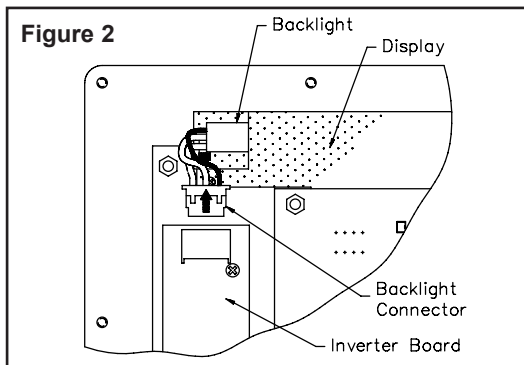
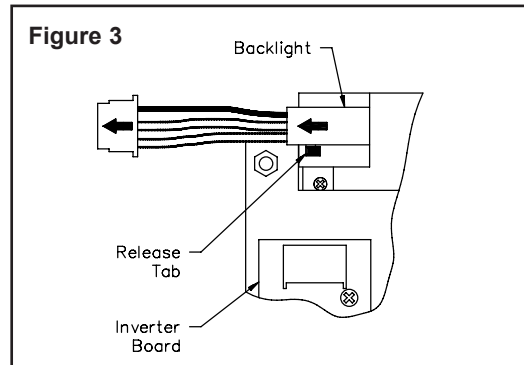

Figure 3



Red Lion Controls  
20 Willow Springs Circle  
York PA 17402  
Tel +1 (717) 767-6511  
Fax +1 (717) 764-0839

Red Lion Controls BV  
Basicweg 11b  
NL - 3821 BR Amersfoort  
Tel +31 (0) 334 723 225  
Fax +31 (0) 334 893 793

Red Lion Controls AP  
31, Kaki Bukit Road 3,  
#06-04/05 TechLink  
Singapore 417818  
Tel +65 6744-6613  
Fax +65 6743-3360